

# formant

music synthesiser

description,  
design,  
construction and  
introduction to  
playing techniques

Elektor publishers Ltd

C. Chapman

**elektor**

**formant  
music synthesiser**

description, design,  
construction and introduction  
to playing techniques

C. Chapman

# Preface

In the May 1977 issue of *Elektor* there appeared the first of a series of articles devoted to the Formant a sophisticated music synthesiser whose performance was on a par with that of many commercial models but which was designed for home construction and could be built for a fraction of their cost. It quickly became apparent that there was tremendous interest in the project. Many readers have since completed construction of the Formant, and their experiences have been entirely positive. The basic modular design concept, which allows the constructor to build as many (or as few) modules as his budget permits, has proven extremely successful, and despite their complexity, an almost 100% reproducibility in the performance of the circuits has been achieved.

In view of the continued popularity of the project, we have decided to gather together and reproduce the original articles describing the design and construction of the Formant. At the same time, we have taken this opportunity to explore the musical capabilities of the Formant in somewhat greater detail than was originally permitted. A synthesiser can be a difficult instrument for the beginner to master. For this reason Part 2 of the book consists of an introduction to the techniques of actually playing the Formant. The characteristics of each module are discussed, and basic control settings for the simulation of specific instruments are described.

A novel feature of the book is that it is accompanied by a demonstration cassette, which allows the Formant enthusiast to hear for himself what the results of certain control settings should sound like and which provides some idea of the enormous musical scope of the instrument.

The availability of printed circuit boards and front panels for each of the modules makes the Formant a true home construction project and ensures that the enthusiast will have a finished instrument whose appearance he can be proud of.

# Contents

<b>Preface</b> .....	<b>3</b>
<b>PART 1</b>	
<b>FORMANT - DESCRIPTION AND CONSTRUCTION</b>	
<b>Chapter 1</b> .....	<b>7</b>
<b>Introduction.</b> Synthesisers are something of a mystery to many people, this chapter therefore provides an introduction to the basic principles of synthesisers in general.	
<b>Chapter 2</b> .....	<b>11</b>
<b>Keyboard and Keyboard Interface.</b> The description of the Formant begins with the keyboard and associated electronics.	
<b>Chapter 3</b> .....	<b>19</b>
<b>Keyboard Construction and Power Supply.</b> In addition to constructional details of the keyboard case, this chapter commences the description of the voltage-controlled module unit, starting with the power supply and a discussion of the module case.	
<b>Chapter 4</b> .....	<b>29</b>
<b>VCO.</b> The VCOs (Voltage Controlled Oscillators) provide a choice of 5 different waveforms, and possess an exponential control characteristic (1 V per octave). This chapter describes the basic design of the VCOs and discusses the musical significance of this module.	
<b>Chapter 5</b> .....	<b>36</b>
<b>Construction of the VCO.</b> Construction, testing and adjustment of the VCOs.	
<b>Chapter 6</b> .....	<b>44</b>
<b>12 dB VCF.</b> The first of the filter modules, which tailor the frequency spectrum of the VCO signal to provide the desired harmonic structure. The 12 dB VCF offers a choice of 4 filter functions (higpass, lowpass, bandpass or notch), and variable Q.	
<b>Chapter 7</b> .....	<b>50</b>
<b>24 dB VCF.</b> For certain applications it is desirable to have a filter with an extremely steep roll-off. The design presented in this chapter offers a choice of highpass or lowpass functions, and a filter slope of either 6, 12, 18 or 24 dB per octave.	
<b>Chapter 8</b> .....	<b>58</b>
<b>Resonance Filter Module.</b> The RFM is designed to allow more realistic simulation of conventional musical instruments by providing the fixed bandpass resonances which are an important determining factor in the timbre of mechanical tone generators. The module contains three separate resonance filters, whose centre frequency, Q and gain can be independently varied.	
<b>Chapter 9</b> .....	<b>64</b>
<b>ADSR.</b> The ADSR (Attack-Decay-Sustain-Release) module is used to control the VCF and VCA and thereby control the dynamic harmonic structure and dynamic amplitude characteristics of the VCO signals.	
<b>Chapter 10</b> .....	<b>70</b>
<b>VCA.</b> The VCA (Voltage Controlled Amplifier) determines the amplitude contour of the output signal. The module in fact contains a DUAL VCA, which can be used in conjunction with an envelope shaper for dynamic control of signal amplitude and also with a low frequency modulation signal to provide tremolo.	
<b>Chapter 11</b> .....	<b>76</b>
<b>LFOs and Noise Module.</b> The LFOs (Low Frequency Oscillators) provide low frequency modulation signals for the VCOs, VCFs and VCA permitting tremolo, vibrato and other similar effects to be obtained. The NOISE module provides the basic material to synthesise a whole spectrum of sounds which have no defined pitch.	
<b>Chapter 12</b> .....	<b>83</b>
<b>COM.</b> Part 1 is brought to a close with a description of the COM (Control and Output Module), and an overall wiring diagram for the 'basic' Formant system.	

**PART 2****PLAYING THE FORMANT**

Basic control settings and musical tips  
on how to play the Formant

<b>Introduction</b> .....	<b>88</b>
<b>Chapter 1. Extending the Formant</b> .....	<b>89</b>
<b>Chapter 2. Control settings of individual modules</b> .....	<b>89</b>
<b>VCOs</b> .....	<b>89</b>
Main characteristics of the VCOs • Tuning the VCOs • Pulse width modulation (PWM) • Ring modulation using PWM • VCO Waveforms • Frequency modulation • ECV/KOV Interface •	
<b>VCFs and RFM</b> .....	<b>94</b>
Main characteristics of the VCFs • Using the VCFs as tracking filters • Using a VCF as resonance filter • Other filter settings • Pedal-controlled Wa-Wa • RFM •	
<b>VCA</b> .....	<b>97</b>
Main characteristics of the VCA • Tone colour- and amplitude dynamics • Linear amplitude modulation • Expression and swell pedal •	
<b>ADSR envelope shapers</b> .....	<b>99</b>
Main characteristics of the ADSR module • Attack-decay contour • Attack-sustain-release contour • Attack-decay-sustain-release contour •	
<b>LFOs</b> .....	<b>100</b>
<b>Noise module</b> .....	<b>100</b>
<b>COM</b> .....	<b>100</b>
<b>Chapter 3. Control Settings for the simulation of different instruments</b> .....	<b>100</b>
Synthesiser size and musical performance • Simple flute sounds • Simple brass sounds • Realistic tone colour through resonance filtering • Improved brass sounds • Multi-voice brass sounds • Some typical synthesiser effects with no natural equivalents • Oboe, bassoon and clarinet • String instruments • Improved flute sounds • Organ sounds • Piano- and piano-related sounds • Gong-, bell- and glockenspiel sounds • Further tonal possibilities • Using the Formant with other instruments •	
<b>Elektor Decoder</b> .....	<b>109</b>
<b>Elektor Print Service</b> .....	<b>109</b>

# Decoder

## Semiconductor types

Very often, a large number of equivalent semiconductors exist with different type numbers. For this reason, 'abbreviated' type numbers are used in Elektor wherever possible:

- '741' stand for  $\mu$ A741, LM741, MC641, MIC741, RM741, SN72741, etc.
- 'TUP' or 'TUN' (Transistor, Universal, PNP or NPN respectively) stand for any low frequency silicon transistor that meets the following specifications:

UCEO, max	20V
IC, max	100 mA
hfe, min	100
Ptot, max	100 mW
fT, min	100 MHz

Some 'TUN's are: BC107, BC108 and BC109 families; 2N3856A, 2N3859, 2N3860, 2N3904, 2N3947, 2N4124. Some 'TUP's are: BC177 and BC178 families; BC179 family with the possible exception of BC159 and BC179; 2N2412, 2N3251, 2N3906, 2N4126, 2N4291.

- 'DUS' or 'DUG' (Diode Universal, Silicon or Germanium respectively) stands for any diode that meets the following specifications:

	DUS	DUG
UR, max	25V	20V
IF, max	100mA	35mA
IR, max	1 $\mu$ A	100 $\mu$ A
Ptot, max	250mW	250mW
CD, max	5pF	10pF

Some 'DUS's are: BA127, BA217, BA218, BA221, BA222, BA317, BA318, BAX13, BAY61, 1N914, 1N4148.

Some 'DUG's are: OA85, OA91, OA95, AA116.

- 'BC107B', 'BC237B', 'BC547B' all refer to the same 'family' of almost identical better-quality silicon transistors. In general, any other member of the same family can be used instead.

### BC107 (-8, -9) families:

BC107 (-8, -9), BC147 (-8, -9), BC207 (-8, -9), BC237 (-8, -9), BC317 (-8, -9), BC347 (-8, -9), BC547 (-8, -9), BC171 (-2, -3), BC182 (-3, -4), BC382 (-3, -4), BC437 (-8, -9), BC414

### BC177 (-8, -9) families:

BC177 (-8, -9), BC157 (-8, -9), BC204 (-5, -6), BC307 (-8, -9), BC320 (-1, -2), BC350 (-1, -2), BC557 (-8, -9), BC251 (-2, -3), BC212 (-3, -4), BC512 (-3, -4), BC261 (-2, -3), BC416.

### Resistor and capacitor values

When giving component values, decimal points and large numbers of zeros are avoided wherever possible. The decimal point is usually replaced by one of the following abbreviations:

p (pico-) =  $10^{-12}$   
 n (nano-) =  $10^{-9}$   
 $\mu$  (micro-) =  $10^{-6}$   
 m (milli-) =  $10^{-3}$   
 k (kilo-) =  $10^3$   
 M (mega-) =  $10^6$   
 G (giga-) =  $10^9$

### A few examples:

Resistance value 2k7: 2700  $\Omega$ .

Resistance value 470: 470  $\Omega$ .

Capacitance value 4p7: 4.7 pF, or 0.000 000 000 004 7 F . . .

Capacitance value 10n: this is the international way of writing 10,000 pF or .01  $\mu$ F, since 1 n is  $10^{-9}$  farads or 1000 pF.

Resistors are  $\frac{1}{2}$  Watt 5% carbon types, unless otherwise specified.

The DC working voltage of capacitors (other than electrolytics) is normally assumed to be at least 60 V. As a rule of thumb, a safe value is usually approximately twice the DC supply voltage.

### Test voltages

The DC test voltages shown are measured with a 20 k $\Omega$ /V instrument, unless otherwise specified.

### U, not V

The international letter symbol 'U' for voltage is often used instead of the ambiguous 'V'. 'V' is normally reserved for 'volts'. For instance:  $U_b = 10$  V, not  $V_b = 10$  V.

### Mains voltages

No mains (power line) voltages are listed in Elektor circuits. It is assumed that our readers know what voltage is standard in their part of the world!

Readers in countries that use 60 Hz should note that Elektor circuits are designed for 50 Hz operation. This will not normally be a problem; however, in cases where the mains frequency is used for synchronisation some modification may be required.

# Elektor Printed Circuit Board Service

A complete set of printed circuit boards and front panels for the Formant are available direct from Elektor Publishers Ltd. The boards are pre-etched and ready-drilled. For optimum legibility even under extreme lighting conditions the pre-drilled metal front panels are sprayed matt black with the legends and scales printed in white.

## Front panels

Module	EPS No.
Interface	9721-F
VCO	9723-F
VCF (12 dB)	9724-F
VCF (24 dB)	9953-F
RFM	9951-F
ADSR	9725-F
DUAL VCA	9726-F
LFOs	9727-F
NOISE	9728-F
COM	9729-F

For price information see the latest edition of Elektor, or apply direct to the publishers.

## Printed Circuit Boards

Module	EPS No.
Keyboard Interface	9721-1
Interface Receiver	9721-2
Power Supply	9721-3
Keyboard Divider (one octave)	9721-4
VCO	9723-1
12 DB VCF	9724-1
24 dB VCF	9953-1
RFM	9951
ADSR	9725-1
DUAL VCA	9726-1
LFO	9727-1
NOISE	9728-1
COM	9729-1

# formant

## the elektor music synthesiser

### chapter 1

### introduction

Formant – the Elektor music synthesiser – is an instrument of advanced specification that bears comparison with many commercially available synthesisers, but at a fraction of the cost.

As synthesisers are something of a mystery to many people this first chapter provides an introduction to the basic principles of synthesisers in general.

A synthesiser may be defined as an electronic musical instrument whose tonal characteristics can be varied at will by the musician. This immediately makes the synthesiser different from conventional musical instruments, whose tonal characters are fixed by their physical construction. It also makes the synthesiser different from an electronic organ, since the latter has a fixed set of voices, generally imitative of conventional organ voices, whereas the synthesiser has no fixed tonal characteristics. The synthesiser may be used to imitate conventional instruments, but on the other hand it may also produce sounds that cannot be produced by any conventional acoustic instrument, and which can be generated only by electronic means.

The synthesiser then, is an extremely versatile instrument, and it is a great pity that it is often used to provide monotonous background accompaniment to beat music, or as a 'band in a box' to produce television advertising jingles. Fortunately the capabilities of synthesisers have been fully exploited by musicians such as W. Carlos, K. Emerson, P. Moraz et al.

#### Principles of the Voltage Controlled Synthesiser.

The concept of the voltage-controlled synthesiser and related circuits was originated by Robert A. Moog. Any sound can be characterised by just three

time dependent parameters, namely pitch, tone colour and volume, or to put it in electronic terms, fundamental frequency, harmonic content and amplitude. If these three parameters can be precisely controlled for the duration of a particular sound then that sound can accurately be synthesised. In practice this is obviously limited to fairly simple 'musical' and related sounds.

A synthesiser thus requires three basic circuit blocks: oscillators to generate sounds of the required pitch, filters to produce the required harmonic content, and amplifiers to obtain the required amplitude. Since the three parameters may vary during the existence of a particular sound there must be some means of rapidly controlling the characteristics of these circuit blocks, which is where the concept of voltage control comes in. The *pitch* of a voltage-controlled oscillator (VCO) may be varied by changing the control voltage applied to it. The *cutoff-frequency* of a voltage-controlled filter (VCF) may similarly be varied, as may the *gain* of a voltage-controlled amplifier (VCA).

#### Exponential Voltage Control

The fundamental design parameter of a synthesiser is the control voltage versus frequency characteristic of VCO's and VCF's. In many applications a linear characteristic is required, i.e.  $n$  volts per Hz. However, musicians are concerned

Figure 1. A comprehensive commercial music synthesiser, the Modell 'Sample System 4'.

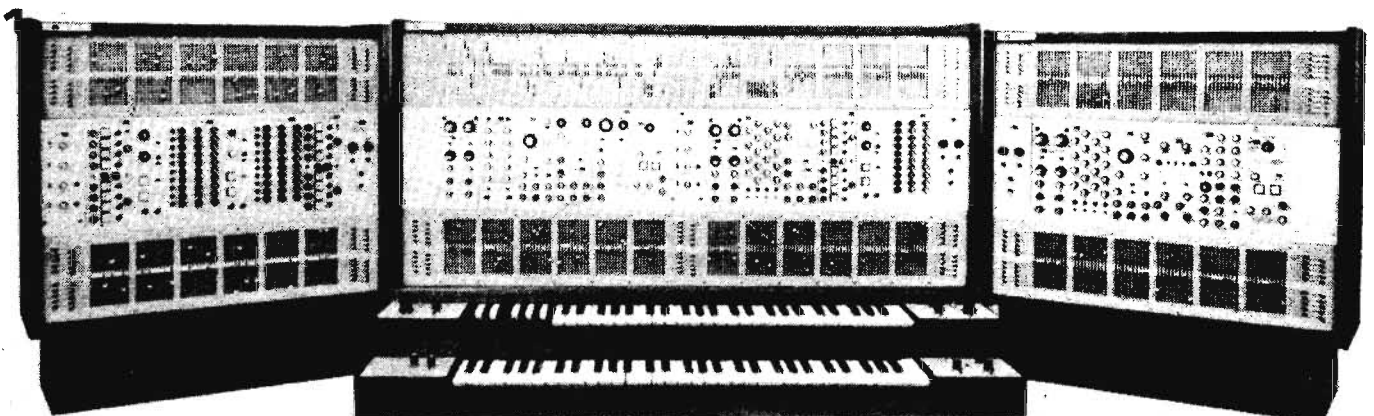

SAMPLE SYSTEM 4



not with linear frequency relationships but with musical intervals, the basic one of these being the octave. For each octave increase in pitch the frequency of a note doubles. This means that if the absolute frequency in Hertz is plotted against the relative frequency in octaves an exponential curve results, as shown in figure 2. It therefore seems more logical from a musical point of view to have a linear control voltage versus octaves characteristic. Figure 3 shows a control characteristic of 1 octave/volt (which is the standard generally adopted). This exponential control has several other advantages which will be discussed later.

An exponential (octave linear) control characteristic may be achieved by preceding a frequency linear VCO or current-controlled oscillator by an exponential generator whose output voltage or current doubles for each one volt increase in input voltage (figure 4). The exponential generator can be preceded by a summing amplifier into which is fed the main control voltage along with other voltages such as a D.C. offset voltage to transpose up and down the scale, and/or A.C. modulating voltages to produce vibrato effects.

### Keyboard Voltage Control

In order to play the synthesiser there must be some method of feeding varying control voltages into the instrument. Since most (Western) musical instruments are tuned and played in the tempered tonic scale it seems logical that a synthesiser should conform to this scale, and the most obvious choice of 'input terminal' is a normal organ keyboard with electrical contacts.

The keyboard circuit (figure 5) consists of a potential divider chain comprising

equal value resistors, fed from a current source. Since there are twelve semitone intervals (and hence twelve key contacts) to an octave, each resistor has a potential difference of 1/12 volt across it. Depressing a particular key connects the voltage on that key contact out to the common bus rail, and thence to the voltage-controlled circuits.

### Transposition

Like an electronic organ, a synthesiser keyboard has only a limited compass (three octaves in the case of Formant). In an organ a wider compass is obtained simply by selecting voices with a lower register. In a synthesiser the compass is extended by adding a D.C. offset voltage to the VCO input (or to the keyboard output) to transpose the range of the keyboard. This is shown in figure 6. An offset of +1 volt transposes the range up one octave, while an offset of -1 volt transposes it down one octave.

### Advantages of exponential control

Figure 7 illustrates the principal advantage of exponential control, which is chording. This shows three VCO's each with three summing inputs. The first input of each VCO is commoned and connected to the keyboard. The second input of each VCO is connected to an independently variable D.C. offset voltage, while the third inputs are all commoned to another variable D.C. offset voltage. Suppose that the independent offsets are adjusted so that the adjacent VCO frequencies are one octave apart, e.g. 1 kHz, 2 kHz and 4 kHz. If the keyboard input increases by one volt then the frequencies will increase to 2 kHz, 4 kHz and 8 kHz respectively, which are still one octave

apart. This would not be the case with a linear VCO. As an example, suppose the first frequency increases by 1 kHz to 2 kHz; the second will also increase by 1 kHz (to 3 kHz), and the third will increase to 5 kHz. This 2-3-5 kHz group no longer shows an octave relationship. Of course, with exponential control one is not confined simply to octave chords. By adjusting the independent offset controls the VCO's may be set up in any musical interval relationship. Additionally any number of VCO's may be employed. The commoned third inputs of the VCO's permit a common offset voltage to be fed to each VCO to transpose the whole chord up or down the scale. A further possibility is to add an offset voltage to the keyboard output to transpose the pitch of the entire synthesiser. This may seem a little confusing at first, but is not so in practice. To summarise:

1. VCO's may be arranged in chording groups. The pitch of each VCO may be varied relative to other VCO's within a group to obtain the required chord, by adjusting the independent tuning controls.
2. The pitch of a chording group may be varied by adjusting the chord transposition control.
3. The pitch of the entire synthesiser may be transposed by an overall transposition control that adds a variable offset voltage to the keyboard output.

### Voltage Controlled Filters

Voltage controlled filters employed in synthesisers are commonly of the lowpass type. A block diagram of their operation is given in figure 8. A D.C. voltage sets the cutoff frequency relative to the pitch of the VCO's, while a control voltage derived from the keyboard shifts this cutoff point up or

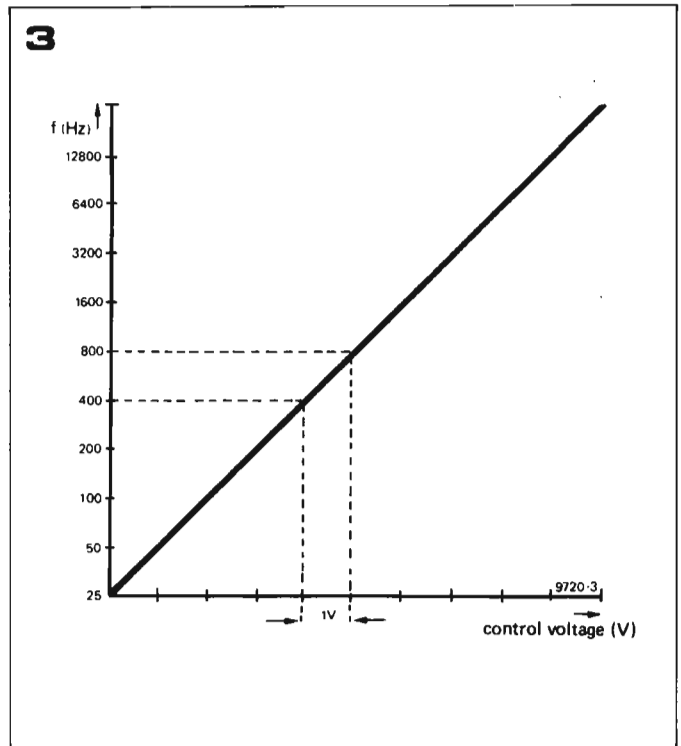
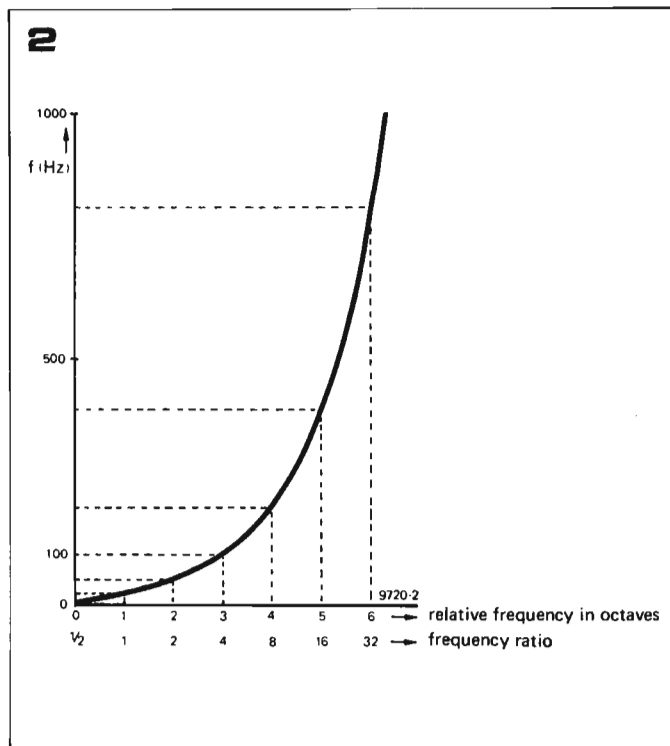



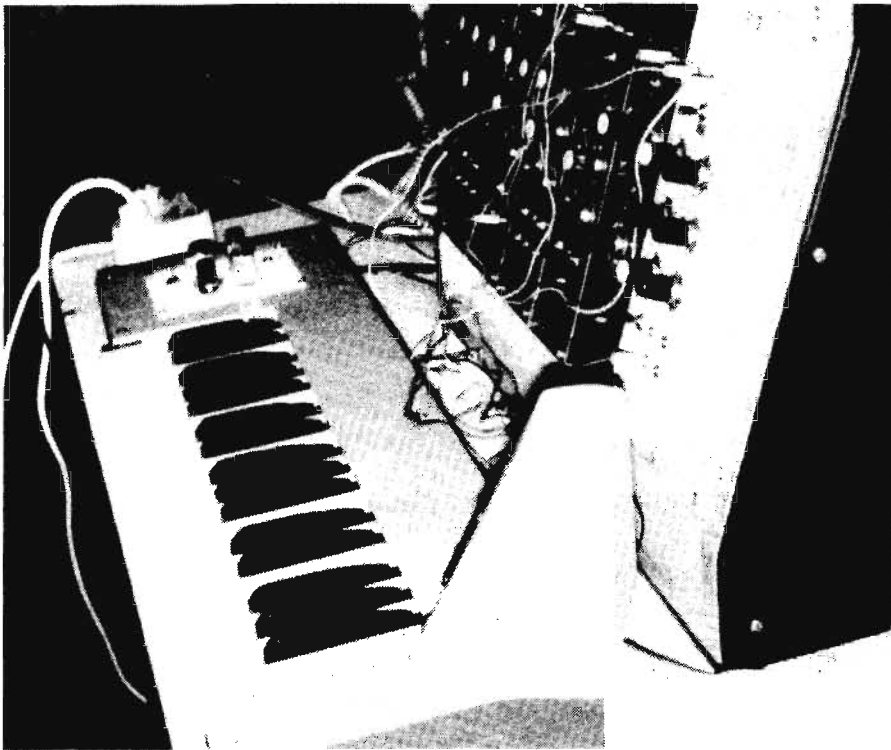

down according to which note is played, so that all notes played, whether high or low, have the same harmonic content. Natural sounds are characterised by dynamic changes of tone colour. A note may start by having a 'bright' character with a large proportion of the higher harmonics, but these then decay rapidly leaving only the fundamental and lower harmonics. Provision must therefore be made to vary the cutoff point during the note. e.g. the cutoff point might initially start off at a fairly high frequency, which would decrease with time to cause the decay of the higher harmonics. This is achieved by means of an envelope shaper which generates a varying voltage having the required characteristics. The envelope shaper is controlled by a gate pulse which is derived from a second set of contacts on the keyboard. The voltage versus cutoff frequency characteristic of the VCF's is again made exponential by preceding the control input of the VCF with an exponential generator.

4

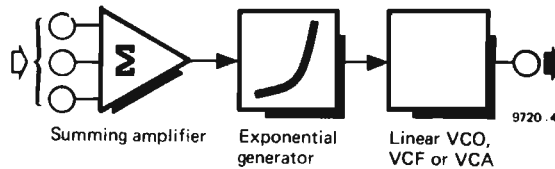

Figure 2. Showing the exponential relationship between relative frequency in octaves and absolute frequency in Hertz.

Figure 3. In common with other synthesisers, Formant has an exponential or octave-linear control characteristic of 1 octave/volt, i.e. if the control voltage is increased by 1 volt the frequency doubles.

Figure 4. Principle of a voltage-controlled synthesiser module according to Moog. This forms the basis of the voltage-controlled modules in Formant.

Figure 5. Showing how the control voltage is derived from the keyboard using a resistive potential divider.

Figure 6. By adding a DC offset voltage to the summing input of the VCO along with the keyboard voltage, the frequency range can be transposed. For example, an offset of +1 V makes the note one octave higher than that actually played on the keyboard. An offset of -1 V would make it one octave lower.

**Voltage controlled amplifiers**

The VCA's are simply amplifiers whose gain may be varied by a control voltage. Their function is to control the duration of a sound, and also its dynamic amplitude characteristics, i.e. its attack, sustain and decay. The VCA is again controlled by an envelope shaper whose output voltage has a form corresponding to the amplitude envelope of the required sound. The VCA of course has no control voltage input from the keyboard, since the amplitude of all notes must remain the same and does not depend upon the frequency of the note being played.

The envelope shaper which controls the VCA is itself controlled by a gate pulse

5

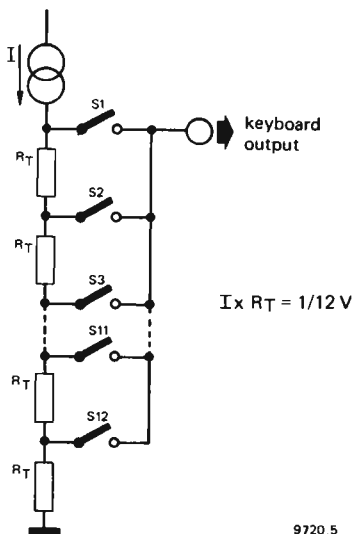

6

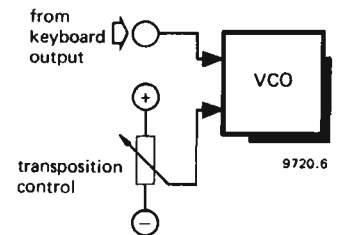

derived from the second contact set on the keyboard, and this determines the duration of the note played.

In the case of both the VCF's and VCA's the output voltage characteristic of the controlling envelope shaper (i.e. the manner in which the envelope voltage varies with time) can be adjusted by the musician. This is extremely important since the dynamic characteristics of a sound largely determine the character of the sound. Returning to conventional musical instruments as an example, if the attack transient at the beginning of a note is removed and only the steady

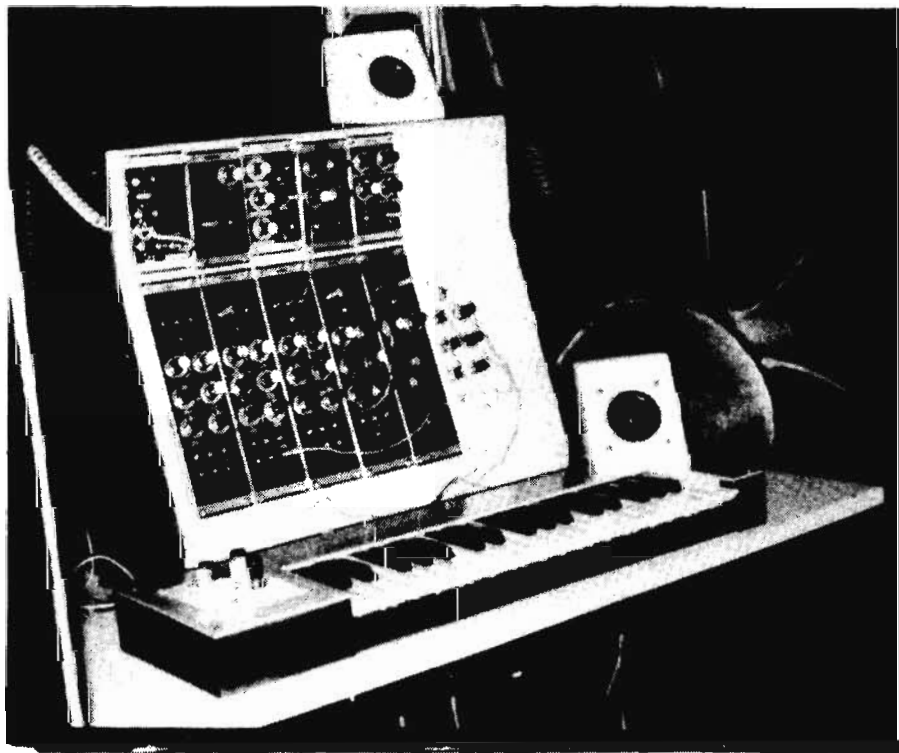
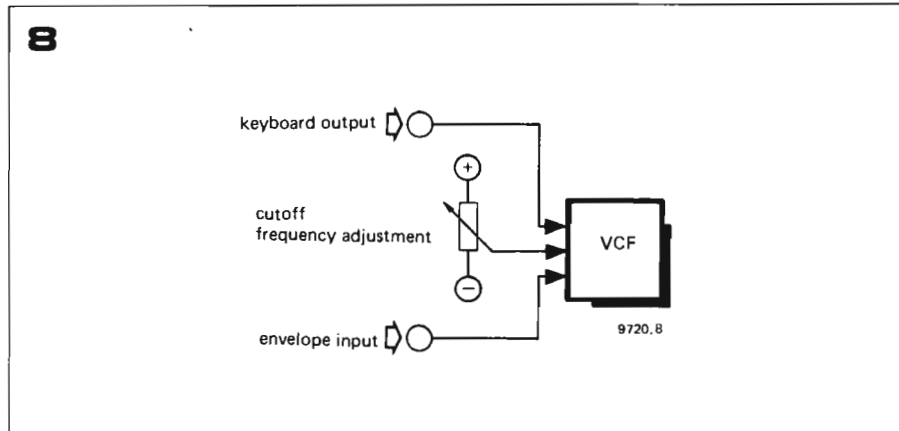
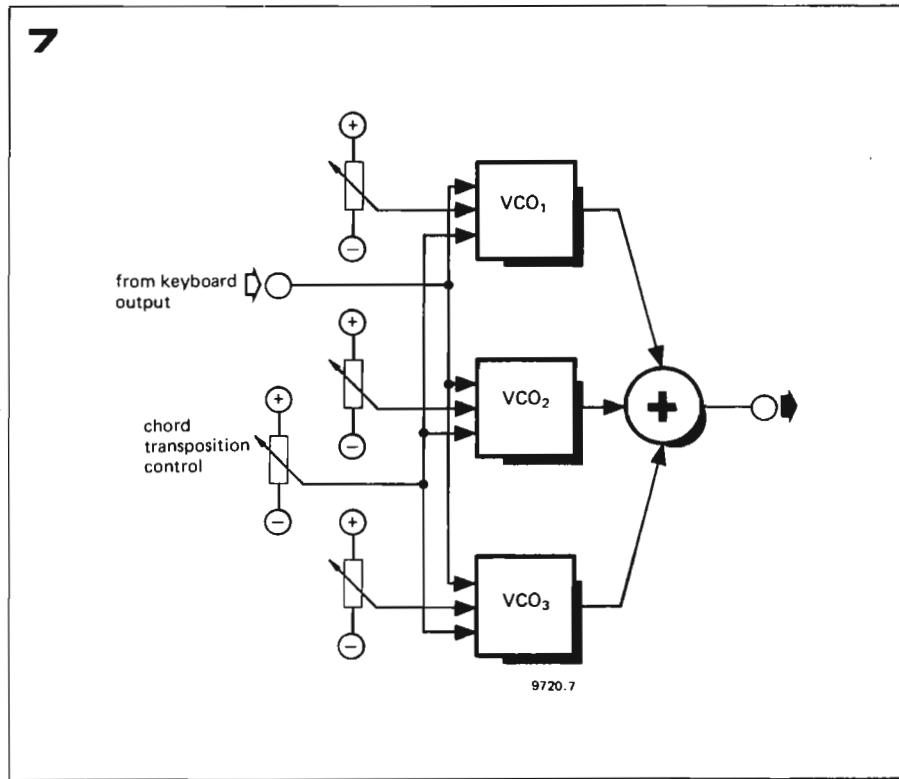

Figure 7. To play a chord, the offset of several VCO's may be adjusted to give the required musical intervals. They can then be controlled simultaneously by the keyboard, and may also be transposed together by a common D.C. voltage. This is known as 'chord transposition'.

Figure 8. The voltage-controlled filter (VCF) is controlled in exactly the same manner as the VCO. The keyboard controls its cutoff frequency, which can also be 'transposed' by a D.C. offset voltage. The third input allows dynamic changes of cutoff frequency during the playing of a note by means of an envelope shaper.

Figure 9. Layout of a basic synthesiser. Several additional blocks are shown such as low-frequency oscillators and noise generator to modulate the voltage-controlled modules, and a noise generator to produce effects such as wind, rain etc.

note is played then it becomes extremely difficult to distinguish between many orchestral instruments. Indeed, it becomes difficult even to determine whether sounds so treated belong to string, brass or woodwind families.

**Synthesiser Block Diagram and Additional Circuits**

Figure 9 shows the block diagram of a basic synthesiser, which contains all the circuits previously described plus a few extras.

At the bottom of the diagram is the keyboard and its interface circuits. These consist basically of the control voltage potential divider, the gate pulse generator and the envelope shapers. In addition there are low-frequency oscillators that provide a signal for periodic modulation (e.g. for effects such as vibrato) plus a noise voltage generator to provide random modulation.

The block containing the VCO's needs little explanation, except for the addition of a noise generator. Since this generates a stochastic signal of no fixed pitch its frequency is not controlled by the keyboard, but the noise signal can be processed by passing through the VCF's and VCA's to produce effects such as wind, water, rain, thunder, steam trains, applause etc., as well as totally unnatural sounds.

The VCO and noise signals are passed through the VCF and then through the VCA, both of which are controlled by the envelope shapers.

**Tonal Character of Synthesisers**

The foregoing description of the basics of synthesisers can hardly give any

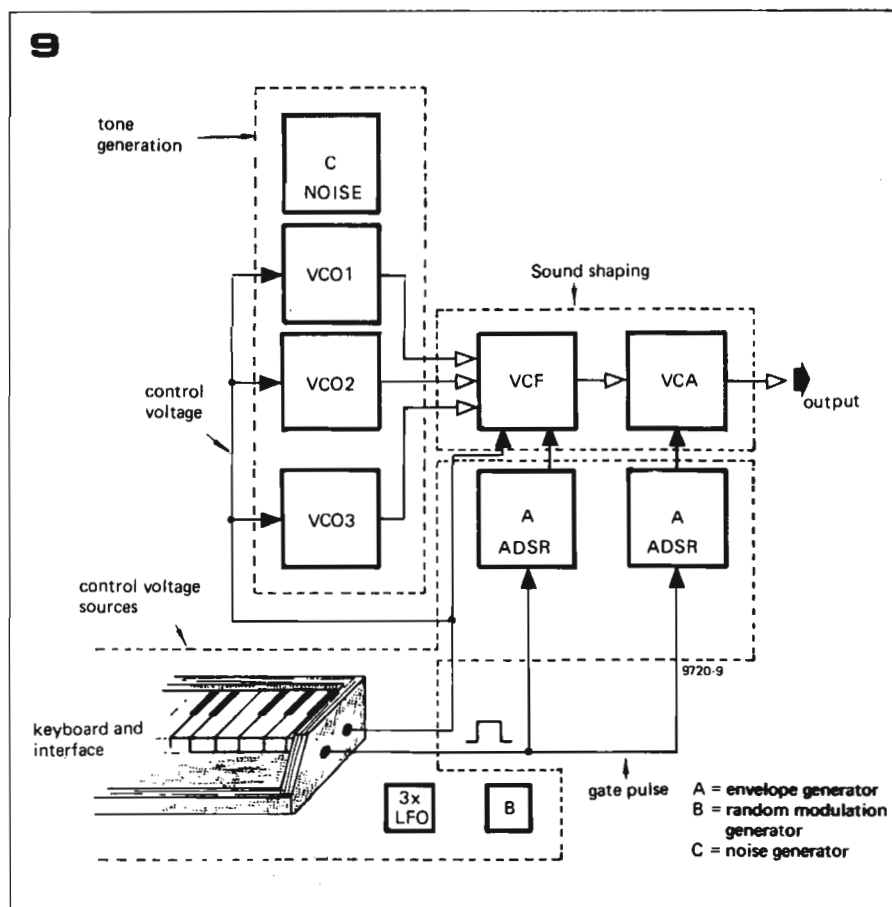

impression of the range of tonal possibilities available with a synthesiser. To begin with, it should not be imagined that the sound produced by a synthesiser is like that produced by an

electronic organ. A synthesiser has much more in common with conventional musical instruments. Whereas the sound of an electronic organ has a fairly static character, a synthesiser is much

more lively and dynamic. The reasons for this are twofold. Firstly, a synthesiser permits precise control of the dynamic characteristics of the sounds produced, whereas an electronic organ (unless it is an expensive one) has only fixed attack and decay characteristics that must suffice for every voice. Secondly, whereas most electronic organs are fixed phase, the synthesiser, with its phase-independent VCO's, can much better produce more 'natural' sounds, which have varying phase patterns.

#### Literature

- Moog R.A. 'Voltage-controlled electronic music modules'. *JAES* 13.3 July 1965.
- 'A voltage-controlled low-pass, high-pass filter for audio signal processing'. *AES Preprint* 413, 1965.
- Burhans R. 'Simplified educational music synthesiser'. *JAES* 19.2, February 1971.
- Orr. T. and Thomas D.W., 'Electronic Sound Synthesiser'. *Wireless World*, August-October 1973.
- Simonton J. 'Build a modular electronic music synthesiser'. *Radio-Electronics*, May-October 1973.
- Shaw G. 'P.E. Sound Synthesiser'. *Practical Electronics*, February 1973-February 1974.
- Tünker H. 'Electronic-Pianos and Synthesiser'. *Franzis-Verlag*, 1975. Nr. 302 (RPB Serie).

## chapter 2

### keyboard and keyboard interface

Having discussed the basic principles of synthesisers, we can now proceed to a description of the Formant itself, starting with the keyboard and associated electronics.

Before going any further it must be stressed that 'Formant' is not a suitable project for the beginner. The complexity of the synthesiser demands a high degree of competence in soldering p.c. boards and interwiring if an unacceptably large number of faults are not to arise. Some knowledge of operational amplifier basics is also almost essential. Nor should the project be undertaken by anyone who does not have access to an oscilloscope, a good multimeter, and preferably a digital voltmeter.

Top grade components are also a must. Where specified, 1% metal film or metal oxide resistors must be used. All other resistors should be good quality 5% carbon film types, while capacitors (except where the capacitance demands an electrolytic) should be low loss, low leakage types such as polycarbonate, polyester or polystyrene. Ceramic capacitors should not be used. Semiconductors too should be first-grade devices from a reputable source, not 'unmarked, untested' manufacturer's rejects. The temptation to save money by buying dubious components should be avoided,

as unsatisfactory performance will almost certainly be the result.

The synthesiser comprises two separate units, the module unit containing VCO's, filters, power supplies etc, and the manual unit containing the keyboard. These two units are interconnected by cables with plug and socket terminations and can be separated for transportation or storage.

The keyboard is a 37-note C to C keyboard fitted with Kimber-Allen two-pole normally open contact blocks. The keyboard used in the prototype was an SKA type. This keyboard is recommended for the project and the descriptions given will relate to it, though other types may also be suitable. The keyboard consists of an aluminium chassis with dimensions similar to those given in figure 1, to which the keys and return springs are assembled. The key contacts are depressed by a plastic actuator on the underside of each key, which protrudes through a hole in the chassis (see figure 1c). Contact blocks are supplied separate from the keyboard, and the first task is to assemble

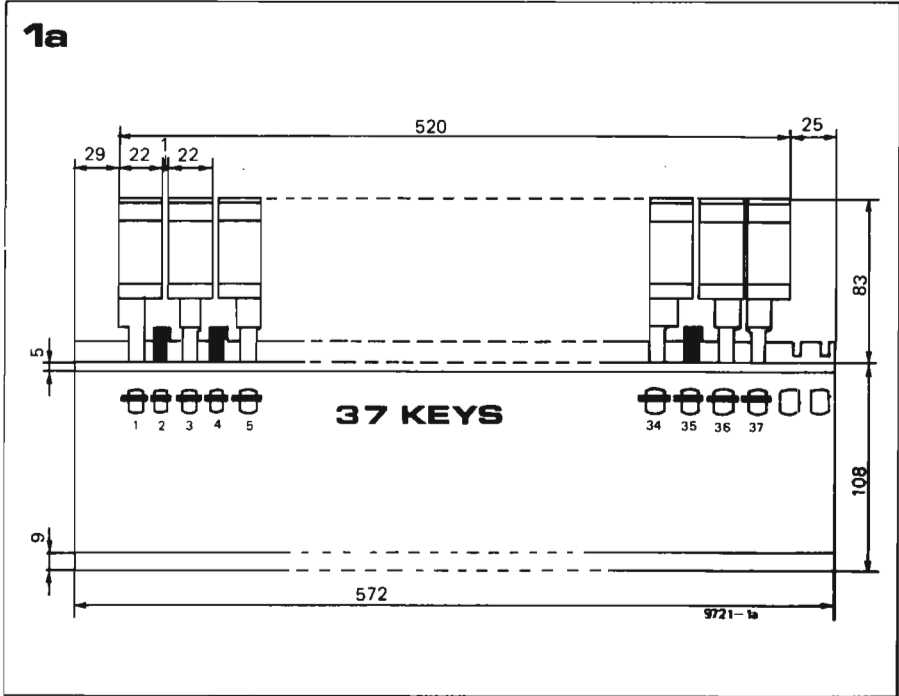

Figures 1a, 1b and 1c. Mechanical details of the SKA keyboard. (A) Keys. (B) Contact actuator. (C) Chassis.

Figures 2a and 2b. Showing the mounting of the key contact blocks. (A) Key. (B) Actuator. (C) Chassis. (D) Contact block. (E) Divider board. (F) Spacer.

Figure 3. Circuit of the keyboard divider chain and current source.

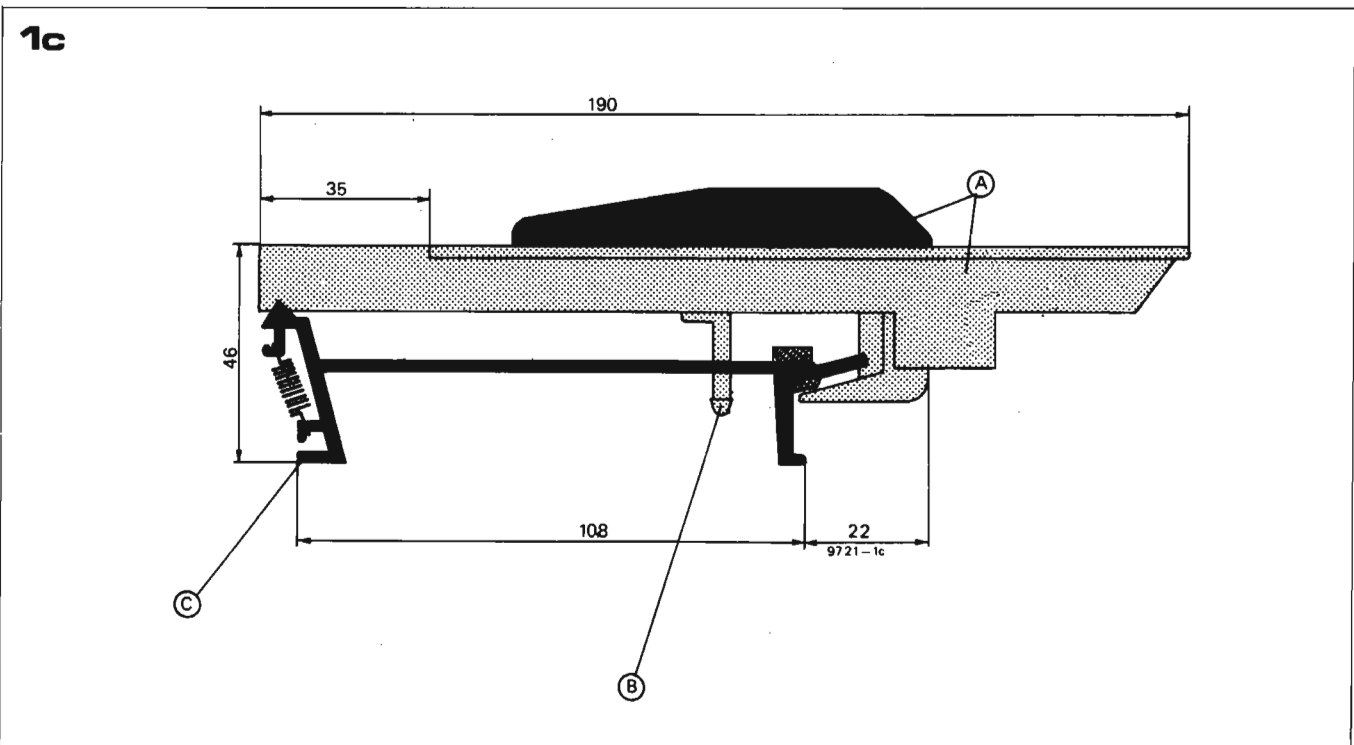
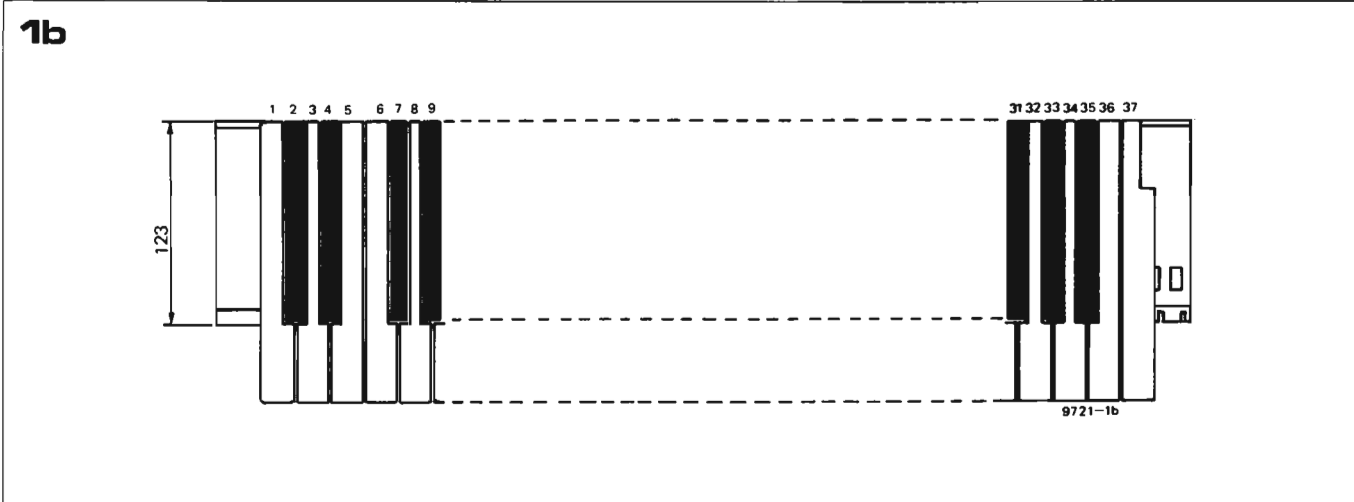

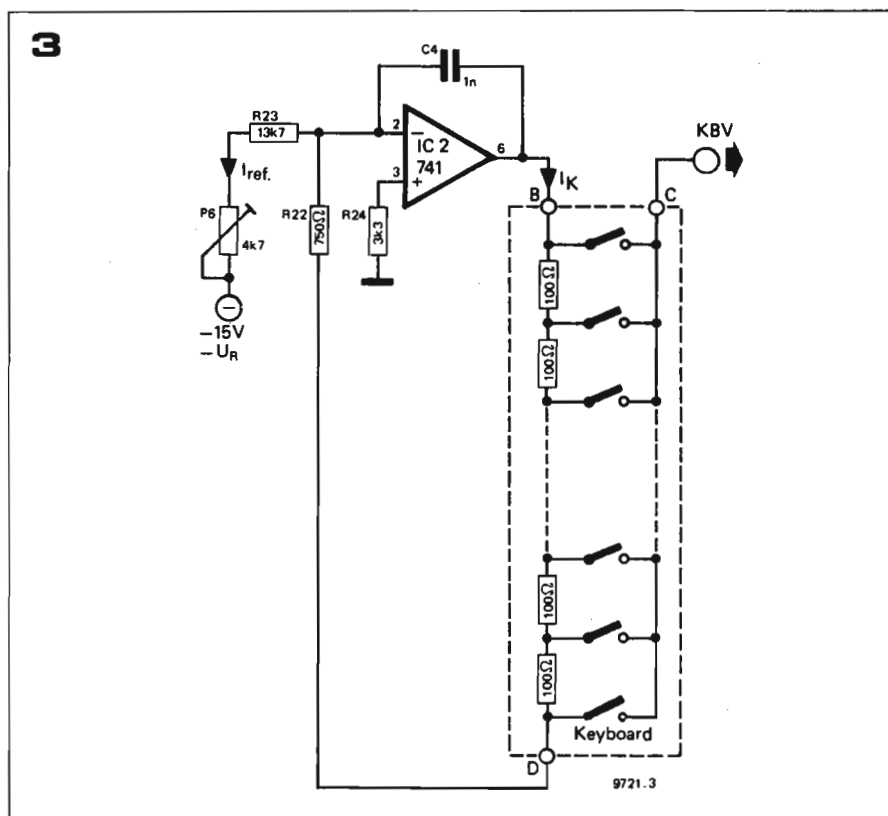
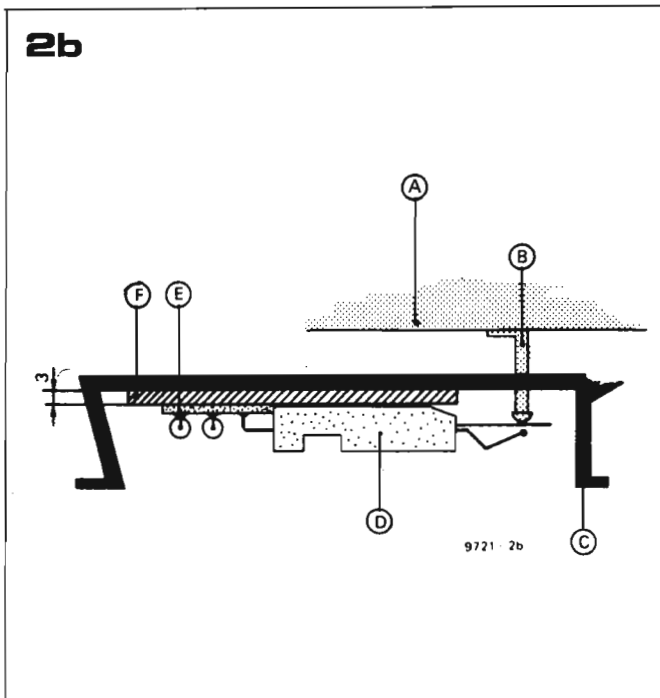
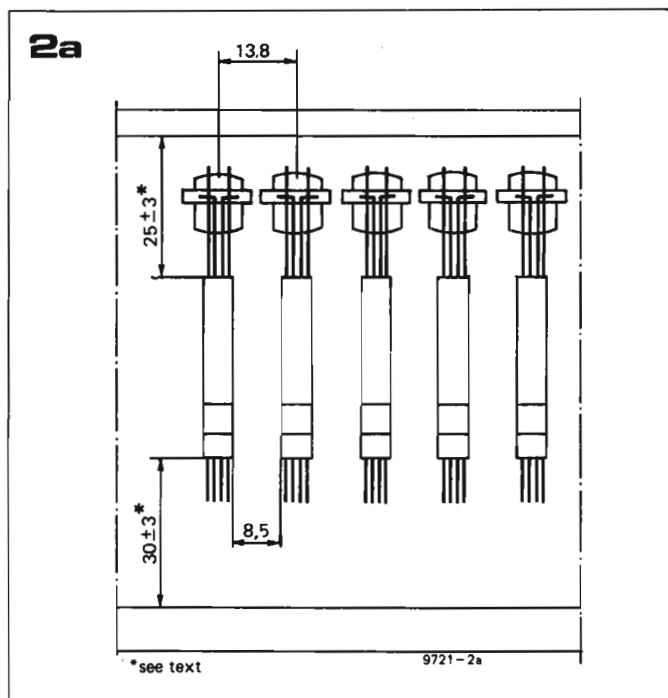

the contacts to the underside of the chassis as shown in figures 2a and 2b. The contact blocks must be spaced away from the chassis so that the actuator (A) just touches the movable contact with the key in the rest position. A strip of 3 mm thick perspex or other plastic makes a suitable spacer (F). The simplest method of fixing the contact blocks in position is to glue them to the plastic spacer using quick setting epoxy adhesive, taking care not to get any adhesive into the 'works' of the contact block. For those preferring a more easily serviceable assembly the slot in the underside of the contact will accept a rectangular section metal strip

which will clamp the contacts to the chassis using nuts and bolts.

#### Keyboard interface

The principle of the synthesiser keyboard, which was briefly explained in chapter 1, is shown in figure 3. The function of one contact-set on the keyboard is to provide a control voltage to the voltage-controlled modules of the synthesiser. Each key can be used to switch a voltage from a particular point in a potential divider comprising equal value close tolerance resistors fed from a constant current source. The control characteristic of the Formant is 1 octave/volt so each resistor in the

chain must drop 1/12 V giving a step of 1/12 V per semitone.

In figure 3 the constant current source is built around IC2, a 741 op amp. From the -15 V stabilised supply a constant current flows through P6 and R23. Since only a negligible bias current can flow into the inverting input of the 741, this same current must also flow out of the op amp output and through the potential divider chain back to the inverting input. Since R24 holds the non-inverting input at ground potential, the voltage at the junction of R22 and R23 is also zero - a 'virtual earth' point. P6 can be adjusted to give a current of 833  $\mu$ A or a voltage drop of 1/12 V across each 100  $\Omega$  resistor, i.e. 83.3 mV. In practice the voltage will not be exactly 83.3 mV but will be somewhat higher to compensate for voltage losses in other parts of the circuit.

It may seem rather strange to use a stabilised reference voltage to produce a constant current which in turn is used to produce a constant voltage. Why not simply feed the potential divider from a constant voltage in the first place? The answer is quite simple. Since the synthesiser is a monophonic instrument only one note can be played at once. If the divider chain were fed from a voltage source and several keys were depressed simultaneously, either by accident or intentionally, then part of the divider chain would be shorted out, increasing the voltage drops across the remaining (unshorted) resistors and giving a discordant note. Feeding from a constant current source means that, even if part of the chain is shorted out the voltage drops across the remaining resistors will stay correct and the note sounded will actually be the lowest note of those played.

#### Sample and hold circuit

It is not possible directly to use the

output voltage of the keyboard to control the synthesiser, since immediately a key is released that voltage disappears abruptly, and so would any tone that was controlled by it, making effects such as sustain impossible. For this reason the output voltage of the keyboard is stored in a sample and hold circuit. This consists basically of a switch and a capacitor connected to the input of an op amp in voltage follower configuration. When the switch is closed the capacitor charges rapidly to the same level as the input voltage. The op amp output also assumes this level. If the switch is now opened, then assuming the op amp has a high input resistance, the capacitor can discharge only extremely slowly, so the op amp maintains its output voltage for a long time.

There are a number of difficulties inherent in this simple approach. Firstly, since the switch in figure 4 corresponds to a key contact of the keyboard, the leakage resistance of the switch when open is the leakage resistance of 37 key contacts connected in parallel, which can be quite low, especially in a humid environment. This could be overcome by increasing the value of the capacitor so that it discharges more slowly, but it would then take much longer to charge from the keyboard divider chain, which would result in unwanted 'glissando' effects. The solution is to use a double sample-and-hold circuit, as shown in figure 5.

The pre S and H circuit stores the output of the keyboard on a small capacitor C1, the output being buffered by a source follower FET T1. Before the voltage on C1 can decay due to the key contact leakage the voltage at the source of T1 is transferred to a larger capacitor C2 by an electronic switch T2. The 'off' resistance of this switch is much higher than that of the keyboard, and T3 has a high input resistance, so C2 can hold its charge for quite a long time. T2 is switched by a gating pulse controlled by the second contact set of the keyboard. The cathode of D1 is normally at -14 V and T2 is thus cut off. When a key is depressed the gate pulse takes the cathode of D1 up to +14 V and T2 turns on.

**Portamento control**

When playing up and down a scale the control voltage from the source of T3 would normally consist of a series of discrete steps, as shown in figure 6a. This would give rise to equally discrete changes of pitch, the minimum change in pitch being one semitone interval of the tempered scale, as with any other keyboard instrument. However, many instruments are characterised by the ability to make continuous (smooth) changes of pitch, one example being the trombone with its slide. This style of playing is known as 'portamento'.

The circuit of a portamento stage is given in figure 7. It consists simply of a source follower FET, preceded by an

RC network that integrates the stepwise output of T3 to give a much smoother change as shown in figure 6b. P1 controls the 'smoothness' of the change. Note that, due to the FET tolerances, the source resistors R2, R4 and R6 must be selected on test, and this will be described in chapter 3.

**Overall tuning, frequency modulation and offset balance**

FETs connected as source followers differ in two essential respects from ideal voltage followers. Firstly, between gate and source there is always the gate-source voltage of the FET, which means that the source is always at a higher voltage than the gate. This appears as an undesirable positive offset voltage at the source of the FET, and since, in this circuit, three FETs are connected in cascade these offset voltages are additive.

Secondly, the gain of a source follower is slightly less than unity, which means that a 1 V change on the gate does not produce a 1 V change at the source.

The offset voltage is compensated for in the circuit of figure 8. This comprises two IC op amps. IC3 is connected as an inverting summing amplifier, while IC4 is connected as a unity gain inverter to restore the correct sense of the control voltage. A negative voltage controlled by P4 may be summed with the control voltage input (KBV") to cancel out the positive offset voltage.

The gain losses in the sample and hold and portamento stages are compensated by increasing the current through the keyboard divider chain by means of P6 in figure 3 until a control characteristic of 1 octave/volt is obtained at the output of IC4.

Figure 4. Showing the principle of a sample-and-hold circuit.

Figure 5. The dual sample-and-hold circuit used in the Formant.

Figure 6. Showing the output waveforms of the keyboard interface when playing a scale (a) normally and (b) portamento.

Figure 7. Circuit of the portamento stage. P1 controls the 'smoothness' of the portamento.

Figure 8. Circuit of the offset compensation, octave tuning and frequency modulation stage.

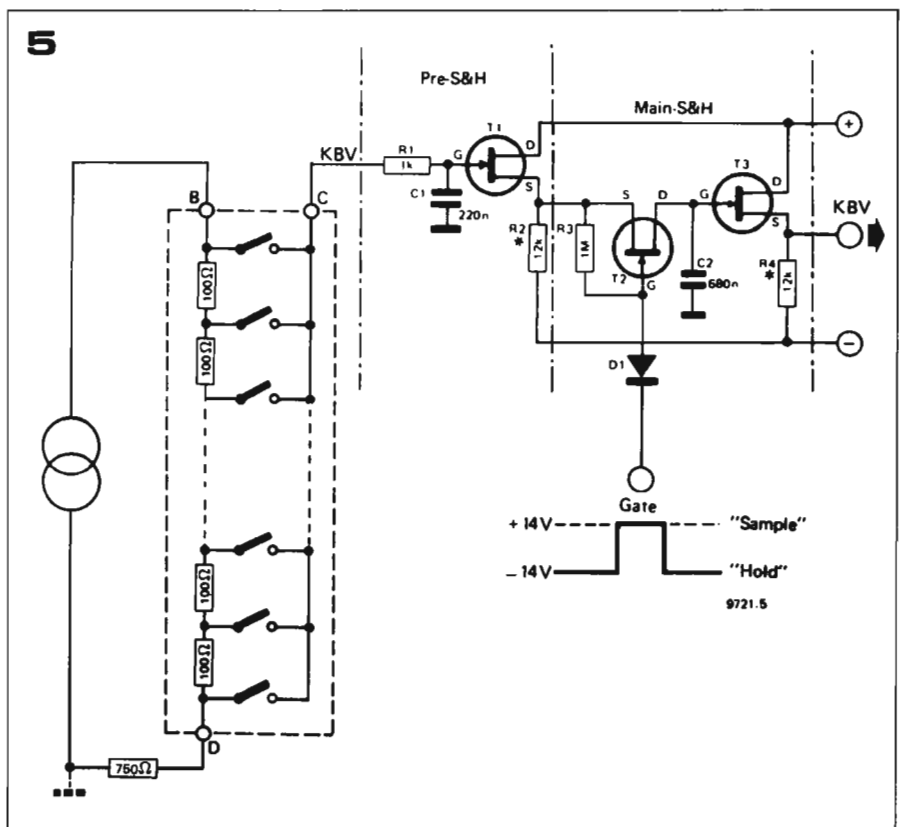
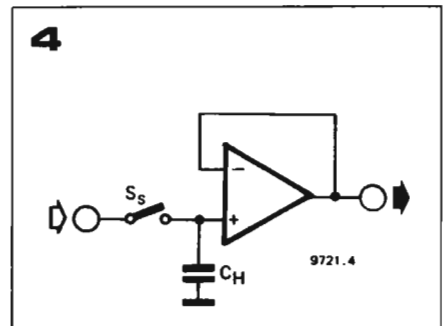

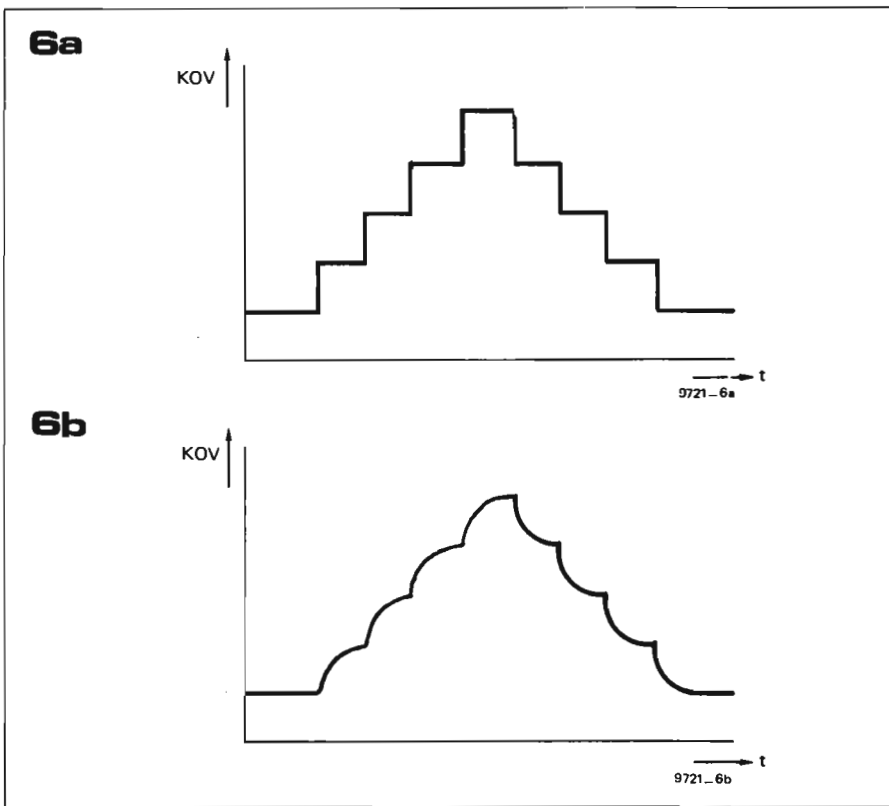

The circuit of figure 8 performs two additional functions. By adding a variable DC voltage to the control voltage the entire tuning range of the synthesiser may be shifted. P2 provides an adjustment of about 5 octaves, while P5 provides a fine adjustment of about ± one semitone, so that the synthesiser can easily be tuned to match other instruments.

A further input is provided for frequency modulation, for example to provide vibrato. The modulation level can be adjusted by means of P3, and with P3 fully clockwise the 'sensitivity' of this input is about 1 octave per 500 mV.

### Gate circuit

Because of the action of the sample and hold circuit, once a key has been depressed the control voltage remains at the KOV output until another key is depressed. This would cause a note, once pressed, to sound indefinitely were it not for the envelope circuits that control the attack, sustain and decay of the notes.

Gate pulses to control the sample-and-hold circuit and to control the envelope shapers are derived from the second set of keyboard contacts. As shown in figure 9, these are all connected in parallel and fed with 4.7 V DC from IC1. When a key contact closes, the output of IC5 immediately goes to +4.7 V. C6 charges via P7 until its voltage exceeds the voltage on the inverting input of IC6 (IC6 functions as a comparator) when the output of IC6 will swing positive. When the key is released the output of IC5 will become zero and C6 will discharge rapidly through D2 so that the output of IC6 will swing negative.

The RC network P7/C6 provides an adjustable delay that compensates for a difference in closing time between the two sets of contacts. For example, should the gating contact close before the control voltage contact then the synthesiser would first sound a note determined by the residual voltage on C1 in figure 5. Then when the control voltage contact closed the correct note would sound. The delay network ensures that the gate pulse is delayed until after the new control voltage has been applied to C1. However, since C6 discharges rapidly through D2 the gate pulse ends immediately the key is released. C5 and R25 at the input to IC5 help to suppress noise due to contact bounce.

### Construction

Figure 10 shows the complete circuit of the keyboard interface, while the printed circuit board and component layout are given in figure 11. The p.c. board for the divider chain is given in the following chapter.

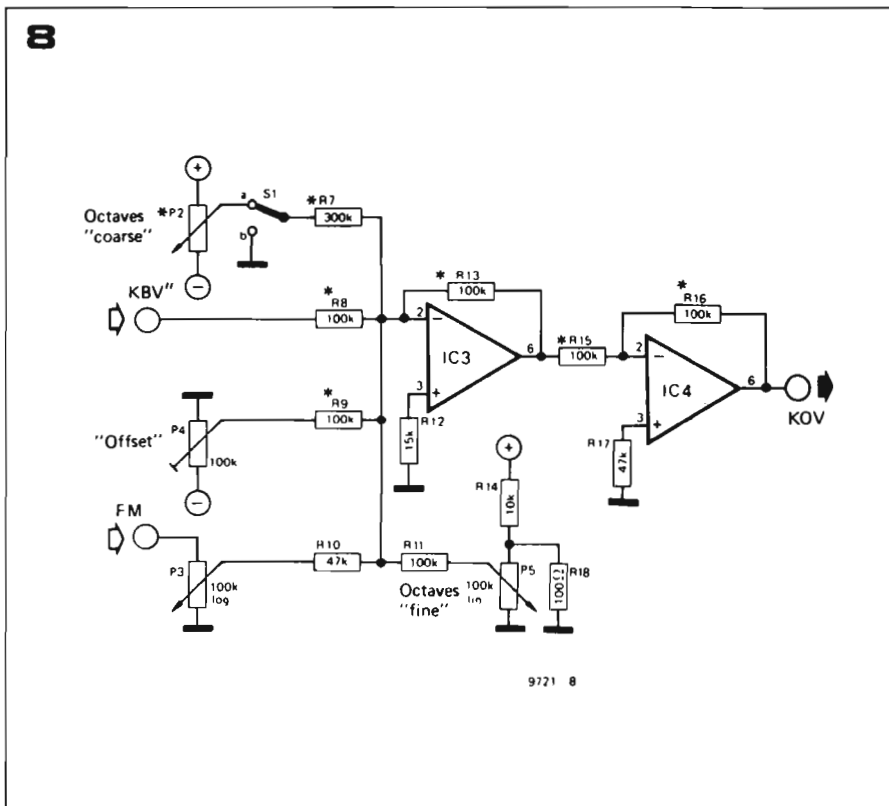
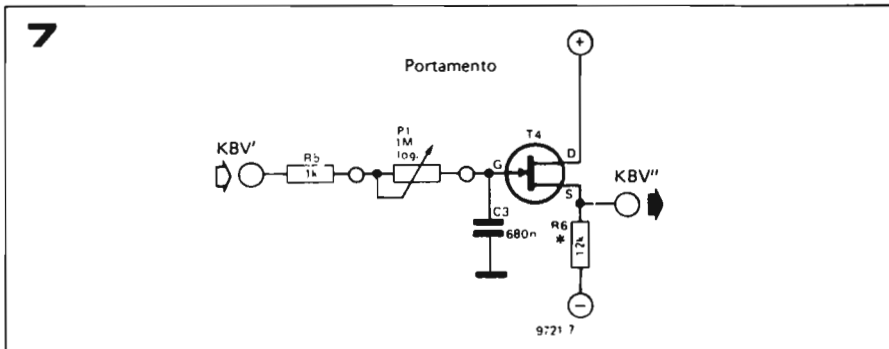



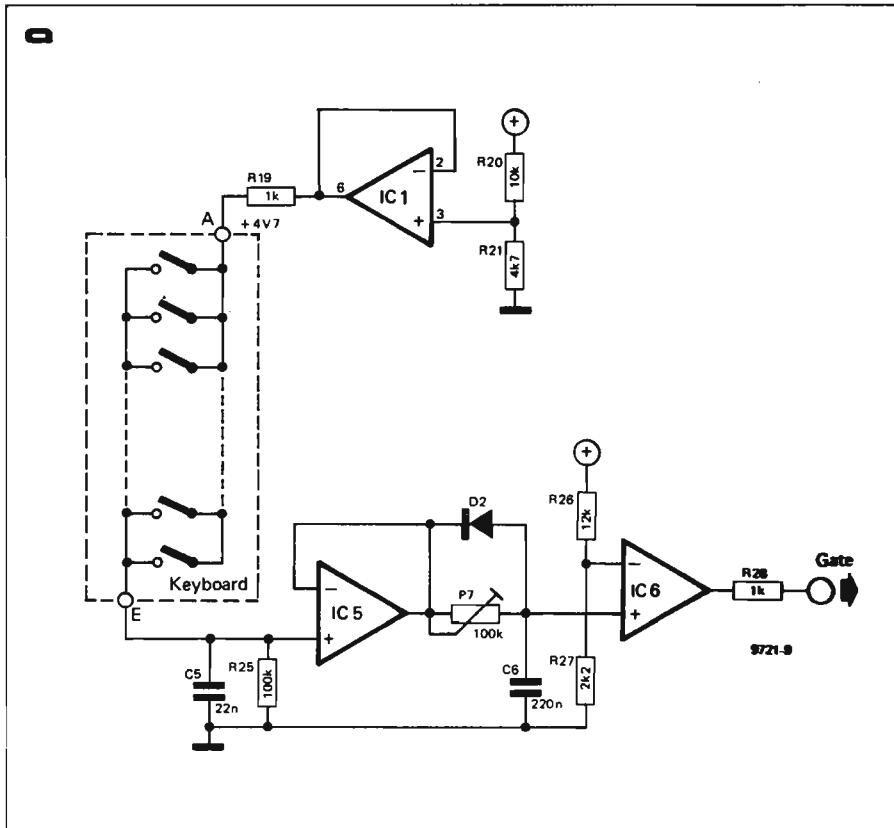
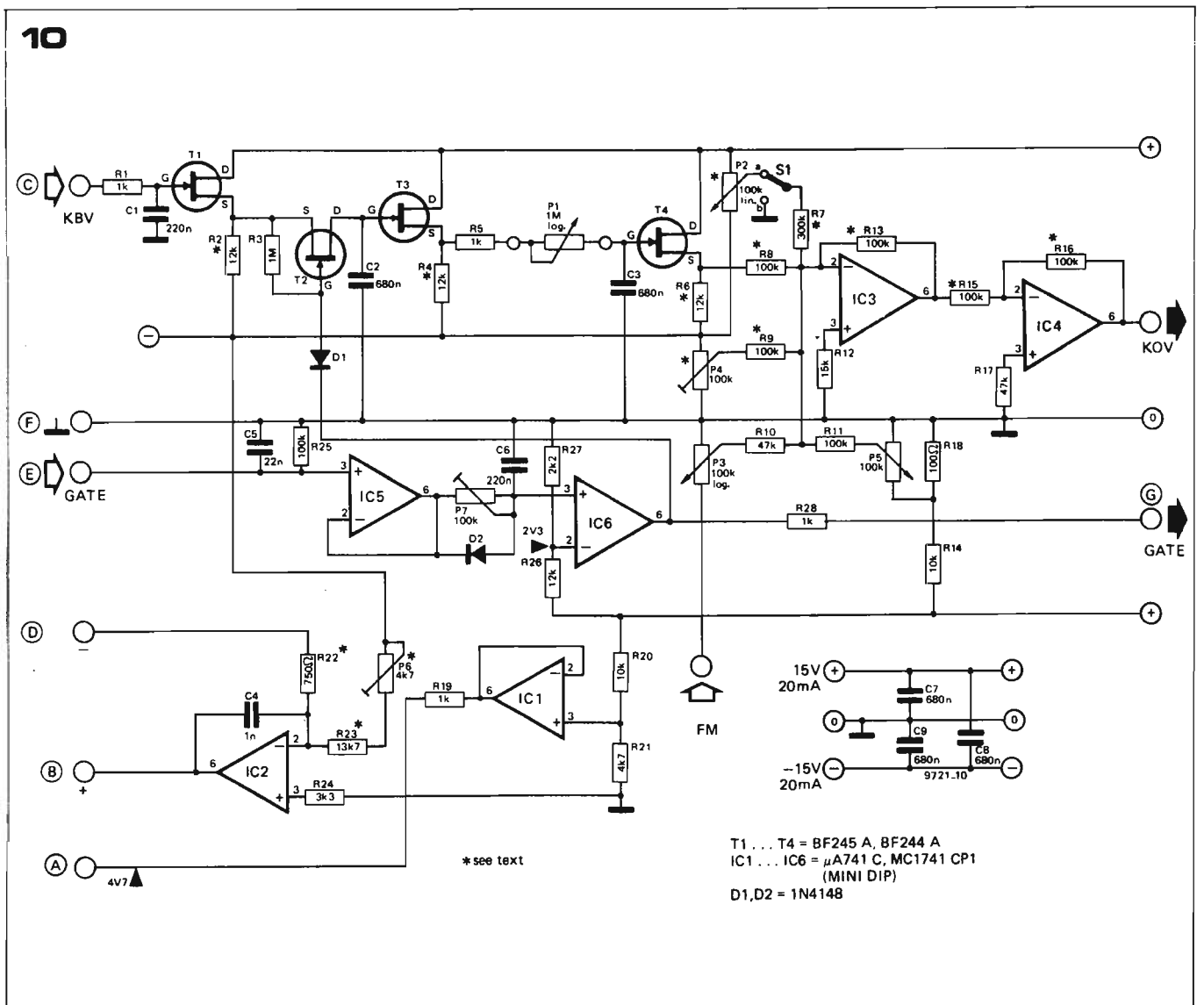

Figure 9. Circuit of the gate pulse generator, which is activated by the second contact set of the keyboard.

Figure 10. Complete circuit of the keyboard interface circuit.



T1... T4 = BF245 A, BF244 A  
 IC1... IC6 =  $\mu$ A741 C, MC1741 CP1  
 (MINI DIP)  
 D1, D2 = 1N4148

\* see text

Photo 1. A Kimber-Allen contact block as used in the synthesiser.

Photo 2. Close-up of the contact blocks mounted on the underside of the keyboard.

Photo 3. View of the completed keyboard with the divider chain p.c. board in position.

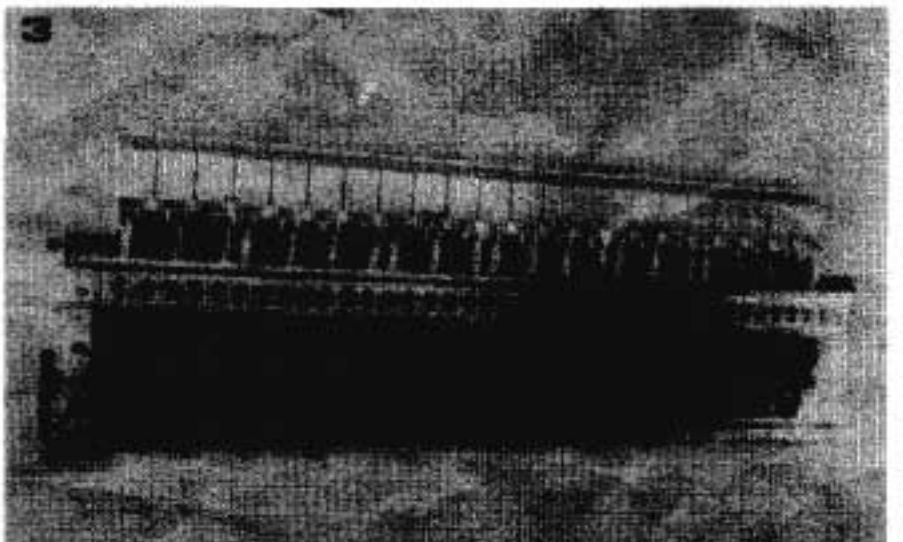
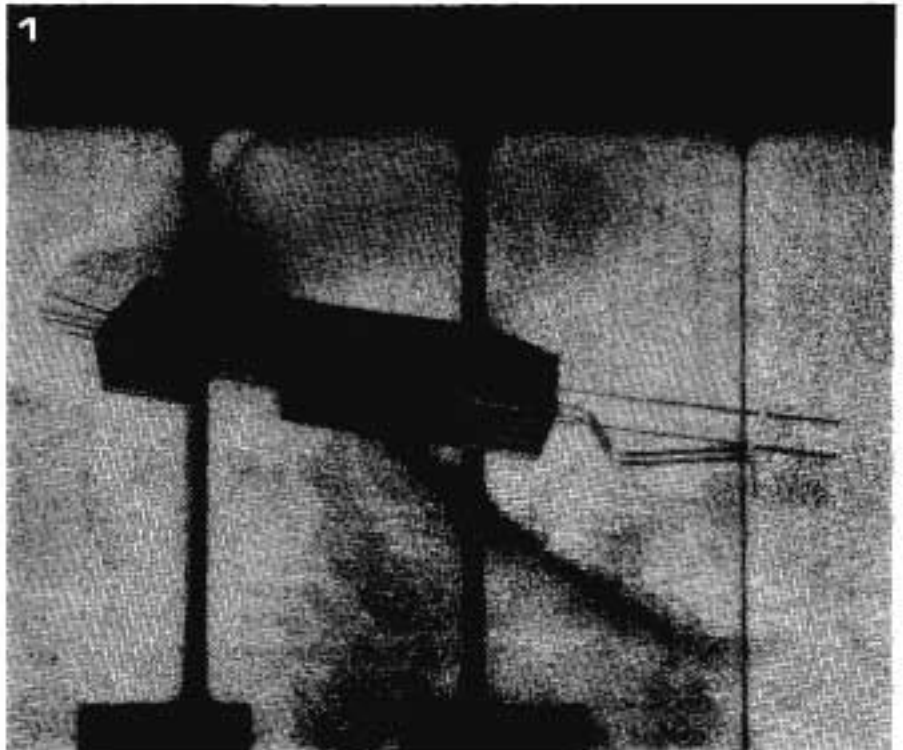

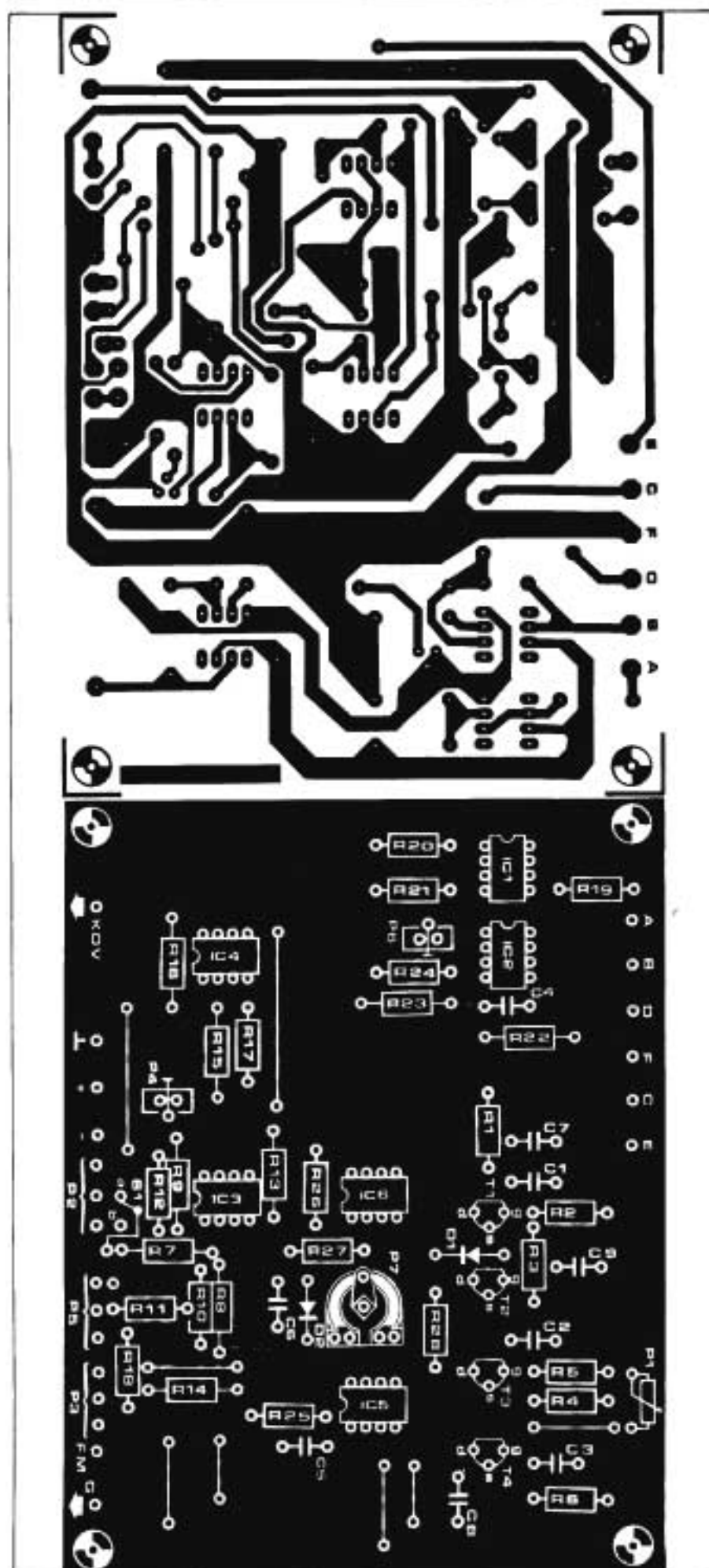

Figure 11. Printed circuit board and component layout for the keyboard interface circuit. (EPS 9721-1)

Parts list to figure 11.

Resistors:

R1, R5, R19, R28 - 1 k  
 R2, R4, R6 - 12 k (nominal value, see part 3)  
 R3 - 1 M  
 R7 - 300 k (1% metal oxide)  
 R8, R9, R13, R15, R16 = 100 k (1% metal oxide)  
 R10, R17 = 47 k  
 R11, R25 = 100 k  
 R12 = 15 k  
 R14, R20 = 10 k  
 R18 = 100  $\Omega$   
 R21 = 4k7  
 R22 = 750  $\Omega$  (1% metal oxide)  
 R23 = 13k7 (1% metal oxide)  
 R24 = 3k3  
 R26 = 12 k  
 R27 = 2k2

Presets:

P4 = 100 k (Cermet)  
 P6 = 4k7 (5 k, Cermet)  
 P7 = 100 k

Potentiometers:

P1 = 1 M log.  
 P2 = 100 k lin. (Cermet)  
 P3 = 100 k log.  
 P5 = 100 k lin.

Capacitors:

C1, C6 = 220 n  
 C2, C3, C7, C8, C9 = 680 n Low leakage, low loss e.g. Siemans MKM, Wima FKS.  
 C4 = 1 n  
 C5 = 22 n

Semiconductors:

T1 ... T4 = BF245A, BF244A (selected, see part 3)  
 IC1 ... IC6 =  $\mu$ A 741 C, MC 1741 CP1 (Mini-DIP)  
 D1, D2 = 1N4148

Notes Except where otherwise specified resistors should be 5% carbon film. Metal oxide types should be 1% or better with temperature coefficient 100 ppm/ $^{\circ}$ C max. Presets and pots, where specified, should be single turn cermet types. In some cases (e.g. for R23) 1% resistors are specified for their long-term and temperature stability, not for the exact value. If this value is difficult to obtain, a close approximation may be chosen, provided a 1% metal oxide resistor is used.

chapter 3

# keyboard construction and power supply

In this chapter the p.c. board layout for the keyboard resistance divider is given, along with constructional details of the keyboard case and the test procedure for the keyboard interface assembly. The description of the voltage-controlled module unit is then commenced, starting with the power supply and details of the module case.

Wiring to the keyboard contacts is largely eliminated by mounting the keyboard divider chain on p.c. boards directly behind the keyboard contacts, so that the 'tails' of the contacts can be soldered direct to the p.c. board. The wiring diagram of the keyboard divider boards is given in figure 1.

The p.c. board and component layout are given in figure 2. Each p.c. board covers one octave of the keyboard, so three p.c. boards are required. They are linked by butting together the ends and wiring across from one board to the next, terminal A to terminal A', B to B' and so on.

At the left-hand end of the keyboard points A to E are joined to the corresponding points on the interface p.c. board by short wire links. Since each keyboard divider p.c.b. has connections for only twelve sets of key contacts the extreme right-hand set of contacts (note 37) must be wired to the end of the p.c.b. as shown in figure 3. Note also the wire link between points B' and D'.

In order that the p.c. boards may be mounted directly behind the key contacts by glueing, the resistors and connections to the p.c.b.'s are on the

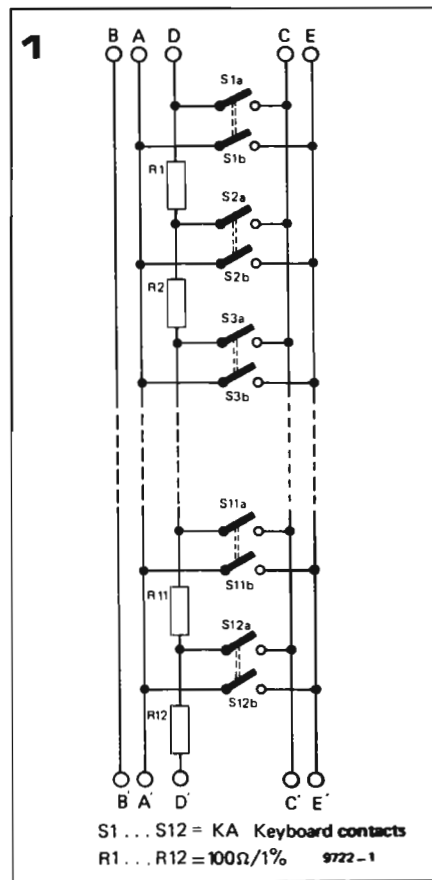

Figure 1. Circuit diagram of one keyboard divider p.c.b.

Figure 2. Printed circuit board and component layout for the keyboard (EPS 9721-4).

Table 1. Selection table for FET source resistors.

copper side of the p.c.b.'s. This can clearly be seen in photo 1. All the resistors are, of course, 100 Ω 1% metal oxide types.

### Selection of FET source resistors

As mentioned in the last article, the source resistors for FETs T1, T3 and T4 must be selected before the keyboard interface p.c.b. can be completed and tested. This is accomplished using the test circuit of figure 4a. With the gate grounded the gate-source voltage  $U_S$  is measured and a corresponding source resistor for each transistor is selected from table 1.

Table 1	$U_S$ (V)	$R_S$ (k Ω)
	0.2	22
	0.25	18
	0.3 ... 0.4	15
	0.4 ... 0.5	12
	0.6 ... 0.8	10
	0.9 ... 1.1	8.2
	1.2 ... 1.6	6.8

At the same time the gate leakage of each transistor should be checked to ensure that it is within acceptable limits. This is done by removing the grounding link across  $C_G$  (330 p). This capacitor will now charge through the gate leakage of the FET, and the source voltage will rise. The rate of change of voltage should be slower than one volt per second. Any FET which cannot meet this criterion should be rejected. This test should also be applied to T2, and when the tests are complete each FET, together with its selected source resistor, can be soldered into the circuit. Due to the possibility of leakage around the sample and hold area of the circuit (T1 to T3) great care should be taken to ensure that the back of the board is scrupulously clean, with no blobs of soldering flux or greasy thumbprints. After testing, the back of the board may be sprayed with insu-

### Parts list to figure 2

- Resistors:  
R1...R12 = 100 Ω/1%
- Miscellaneous:  
S1...S12 = KA keyboard contacts

Note that one board is required for each octave. For a three-octave synthesiser, for instance, three boards and 36 resistors are required. For further details see text, figures 1 and 3 and photos 1 and 2

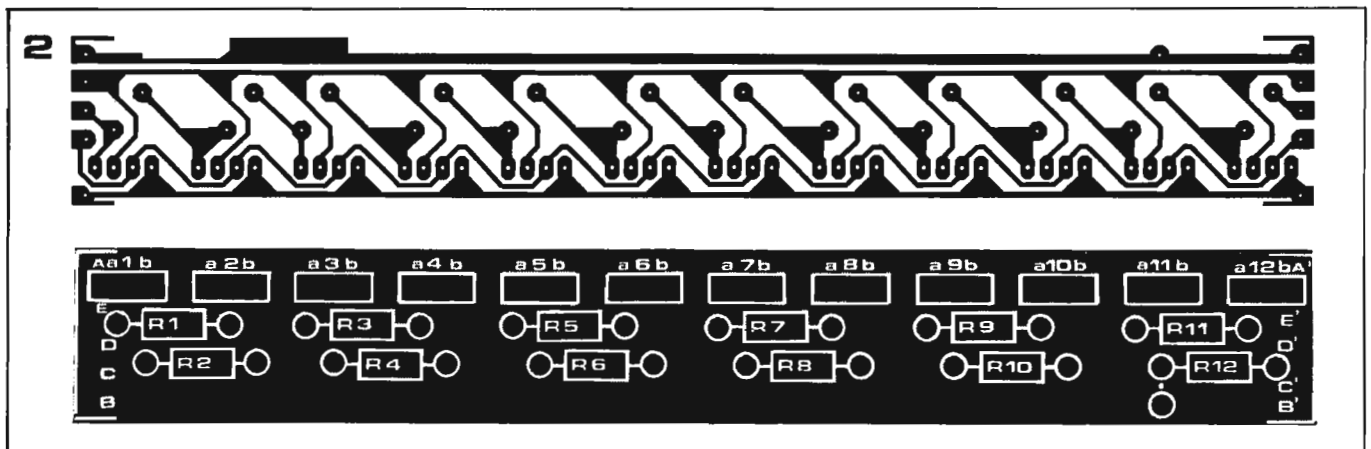

lating varnish.

Although the BF244 or BF245 is specified for T1 to T4, since practically all specimens of this device will function in the circuit, it is possible to use the cheaper and more popular 2N3819 for T2. It should be noted that the board is laid out for the pinning of the BF245. The pinning of the BF244 and most 2N3819's is different, as shown in figure 4b.

**Interface receiver**

In the early design stages the KOV and GATE outputs from the interface board were fed direct into the voltage controlled modules. However, it was soon discovered that the input currents taken by these modules caused significant voltage drops along the connecting cable between keyboard and module unit, especially if this was long. In particular, earth return currents along the common earth wire shared by the KOV and GATE outputs caused modulation of the keyboard voltage by the gate pulse. This problem was overcome by providing high impedance buffer stages at the receiving end of the connecting cable. The circuit for this 'interface receiver' is shown in figure 5. It consists simply of a 741 connected as a voltage follower for the KOV input, and a similar voltage follower with an input delay circuit for the GATE input. The output of this circuit also drives an LED to indicate when a gate pulse is present. A printed circuit board and component layout for the interface receiver are given in figure 6. The two outputs are taken from single screw terminal blocks cut from a 'chocolate block' type of mains connector. This is so that connections to extra voltage controlled modules can be added if and when the system is extended.

**Testing of the keyboard interface assembly**

Once the keyboard interface (see chapter 2, figures 10 and 11) and interface receiver boards are complete they can be tested, provided a ± 15 V supply is available, otherwise the testing must wait until the synthesiser power supply has been built. The final adjustment is not carried out until the keyboard assembly is mounted in its case, but these preliminary tests will show up any faults in the circuits and save a lot of frustration at a later stage. The test procedure is as follows:

**1. Current consumption**

Connect positive and negative supplies to the keyboard interface (chapter 2, figure 10) and measure the current flow in both the positive and negative supply leads. This should be between 18 and 25 mA.

**2. Keyboard current source**

a) Connect a multimeter between points B (positive) and D (negative) and

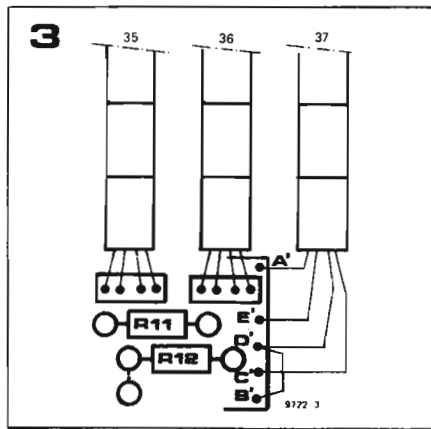

adjustable between 0.8 and 1 mA by means of P6.

b) Check the virtual earth point, pin 2 of IC2. The voltage between this point and the 0 V rail should be less than 5 mV, with a 1 k resistor connected between points B and D.

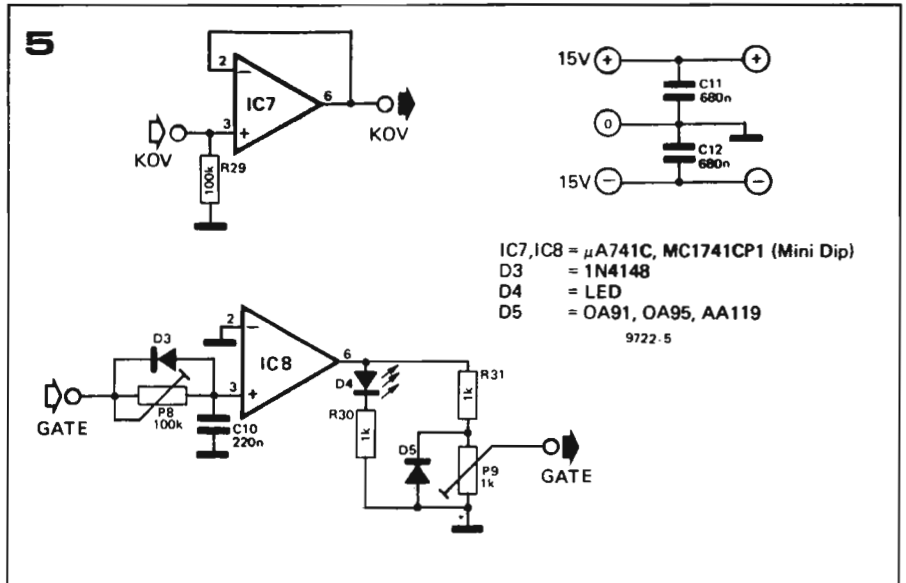
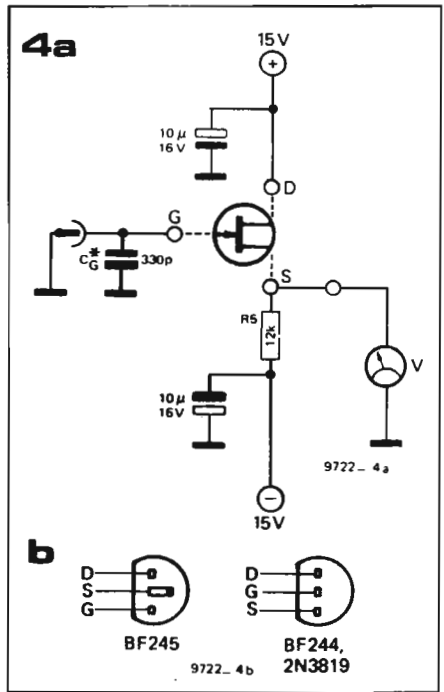

IC7, IC8 = µA741C, MC1741CP1 (Mini Dip)  
 D3 = 1N4148  
 D4 = LED  
 D5 = OA91, OA95, AA119  
 9722\_5

monitor the current. This should be adjustable between 0.8 and 1 mA by means of P6.

b) Check the virtual earth point, pin 2 of IC2. The voltage between this point and the 0 V rail should be less than 5 mV, with a 1 k resistor connected between points B and D.

**3. Gate circuit**

Connect point E on the interface board to point A via a switch and measure the voltage at point G with respect to 0 V. It should be -12 to -15 V with the switch open and +12 to +15 V with the switch closed.

**4. Sample and hold**

a) Retain the switch from the previous test. Connect point C to an SPDT switch so that this point can be switched between point A and ground. With point C grounded, the gate switch closed and P1 set to minimum resistance the source voltage of T4 must be less

Figure 3. Showing the wiring to the 37th key contact block.

Figure 4. Test circuit for FET's and pinouts of BF244, BF245 and 2N3819.

Figure 5. Circuit of the interface receiver.

Figure 6. Printed circuit board and component layout for the interface receiver (EPS 9721-2).

Figure 7. Mounting plate for the interface board.

than 4 V and should not change when the gate switch is opened.

b) Leave the gate switch open and ground point C using the SPDT switch. The source voltage of T4 must not change. Close the gate switch and the source voltage should now rise by between 3.6 and 4.6 V. Open the gate switch and this new voltage should be maintained.

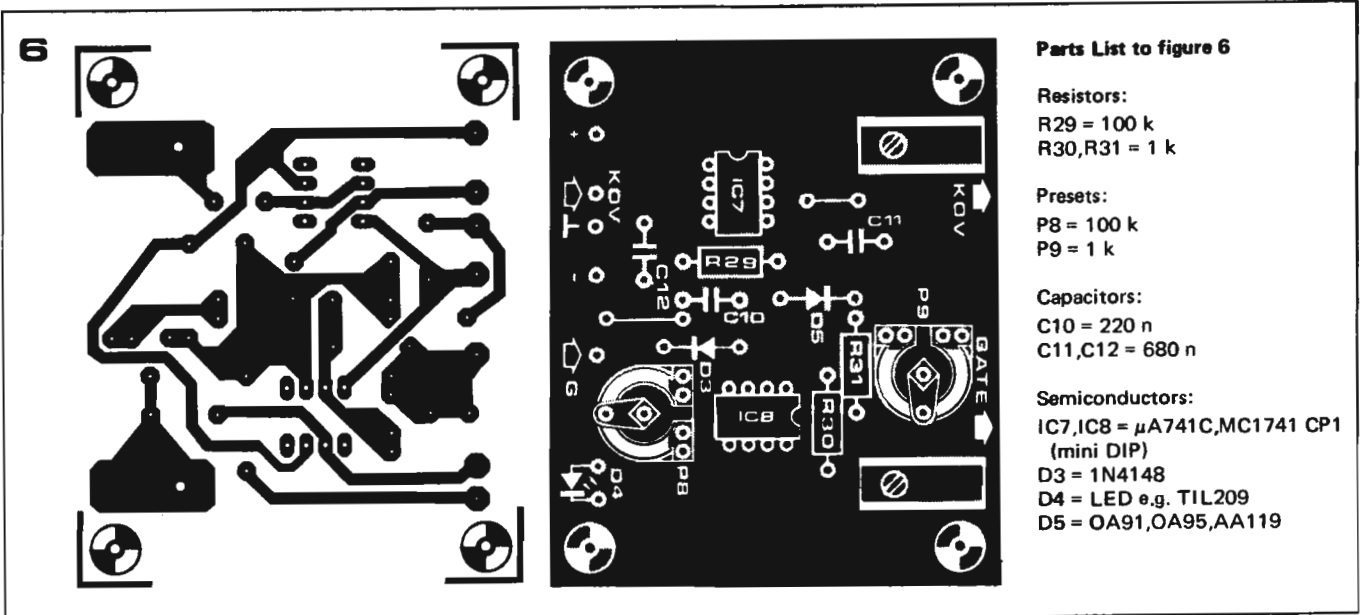

c) Set P1 to maximum resistance, changeover switch to ground point C and close the gate switch. The source voltage of T4 should now drop to its original value over two to three seconds.

#### 5. Summing amplifier

- a) Offset adjustment. Maintain the same switch positions as in test 4c. Using S1, switch P2 out of circuit and turn sliders of P3 and P5 to ground. Use P4 to set the KOV output to zero volts.
- b) Coarse tuning. Switch P2 into circuit using S1 and turn P2 fully clockwise and then anticlockwise, when the KOV output should be +5 V and -5 V respectively.
- c) Fine tuning. Switch P2 out of circuit

and turn P5 fully clockwise, when the KOV output should be about 150 mV.

d) FM. Turn P5 fully anticlockwise. Link point FM to point A on the board. Using P3 it should be possible to vary the KOV output between zero volts and about 10 V.

#### 6. Interface receiver

Interconnect the interface and interface receiver boards (connections GATE, KOV, +15 V, -15 V and ground). Repeat tests 3 and 5b, but monitor the KOV and GATE outputs of the interface receiver. With the gate switch closed the indicator LED should glow. Finally, with the gate switch closed, use P9 to set the gate output voltage of the

interface receiver to +5 V.

#### Keyboard unit assembly

Once the interface board has been tested, it and the keyboard can be joined to make an integrated keyboard unit.

This is accomplished by first making an aluminium mounting plate for the interface board, as shown in figure 7. The 'tongue' of this plate fits along the underside of the keyboard chassis (at the left-hand end) and is secured by three 4 mm nuts, bolts and lockwashers. A solder tag beneath one of the nuts provides an earthing point for the keyboard. Note that the larger diameter hole in the tongue is not used yet; it will be required for mounting the keyboard in its case.

The next step is to mount the keyboard divider boards. As illustrated in photo 1, these boards should be interlinked in such a way that the ends of the boards actually touch at the junction, as otherwise the spacing of the contacts on the board with respect to the switch contact blocks will not be accurate. As described in chapter 2 (and illustrated in figure 2b), the contact blocks should be glued or bolted to a 3 mm thick plastic spacer (F). The keyboard divider boards can now also be mounted on this spacer, using either epoxy adhesive or double-sided self-adhesive tape ('Servotape', 'Tesatape' or similar). Note that the front of the divider boards should touch the contact blocks, as otherwise the wires from the blocks may be too short. The interface board can now be mounted on top of its mounting plate using 4 mm nuts, bolts and spacers, and connections between the keyboard p.c.b.'s and the interface board are made by short wire links which pass through the rectangular slot in the mounting plate. The earthing point for the keyboard chassis is connected to point 'F' on the interface board. The complete assembly can be seen in photos 2 and 3.

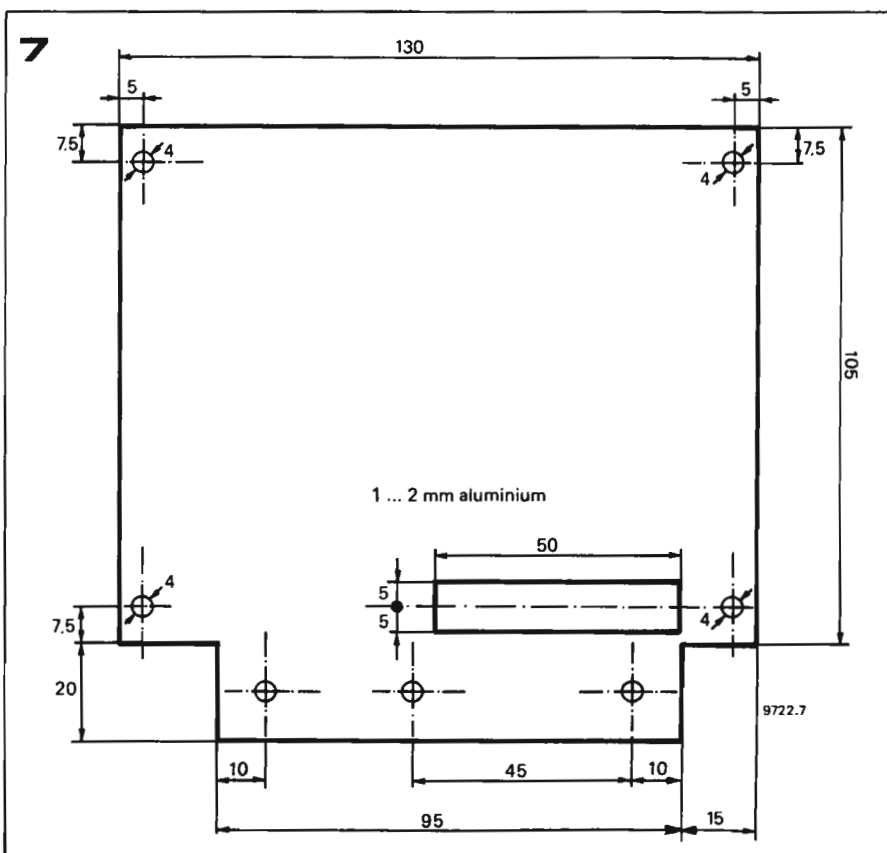

**8a**

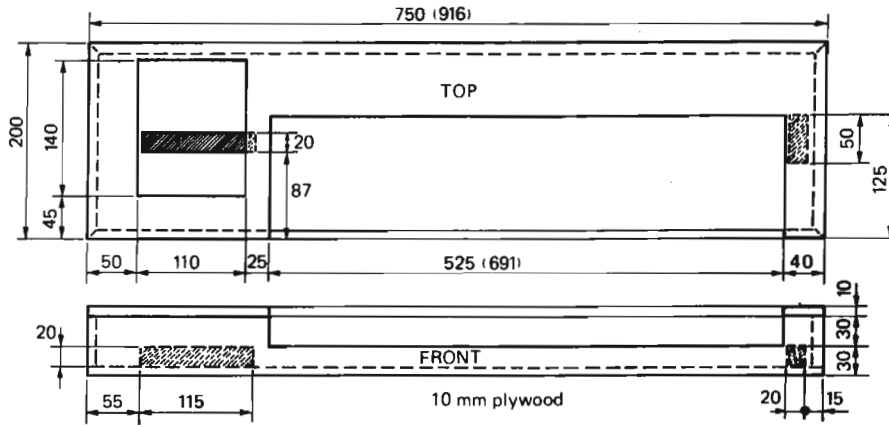

- Notes: 1) All dimensions in mm  
 2) Normal dimensions valid for 3-octave Keyboard  
 3) Dimensions shown in brackets valid for 4-octave Keyboard

9722 8

**b**

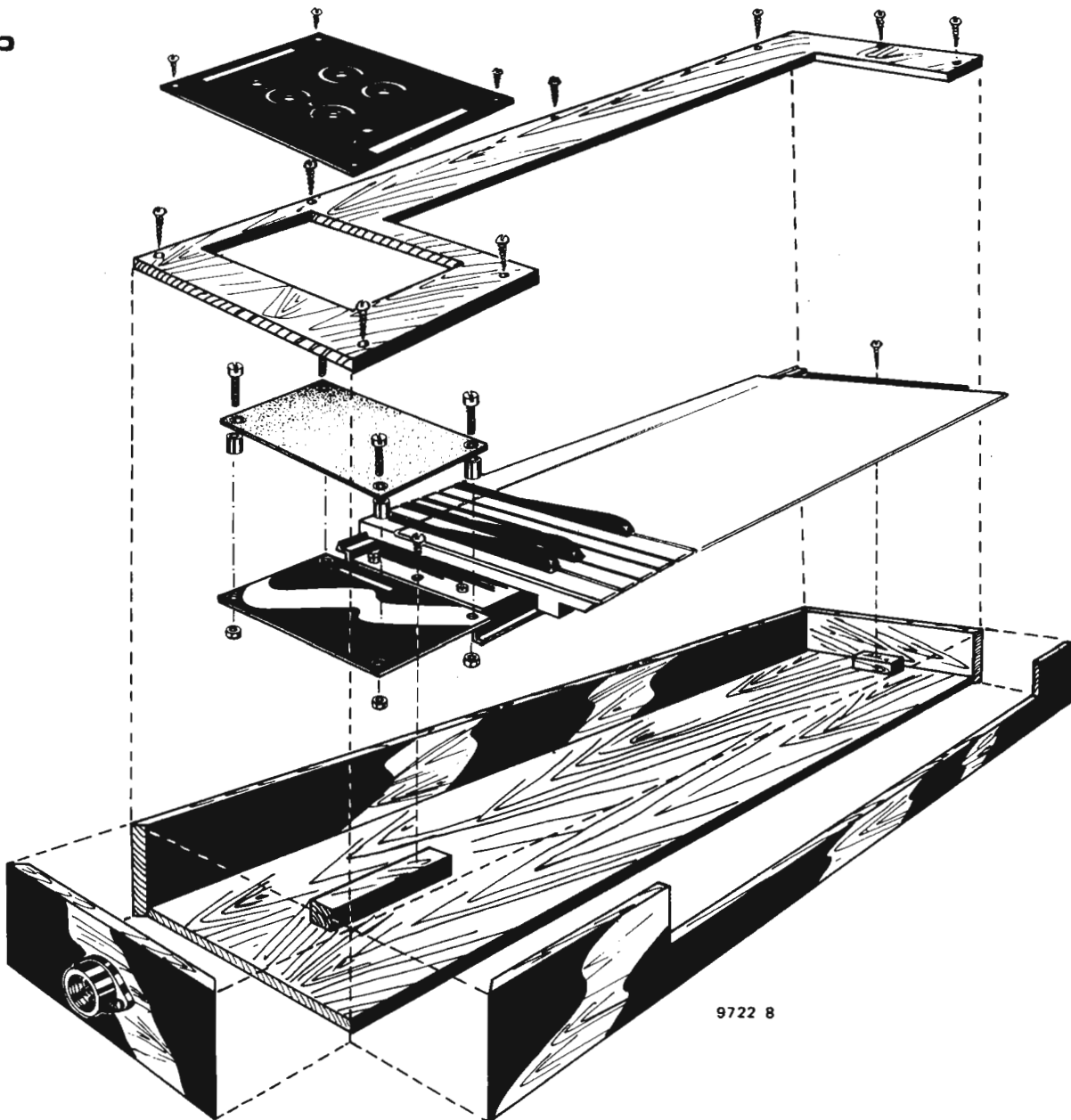

9722 8



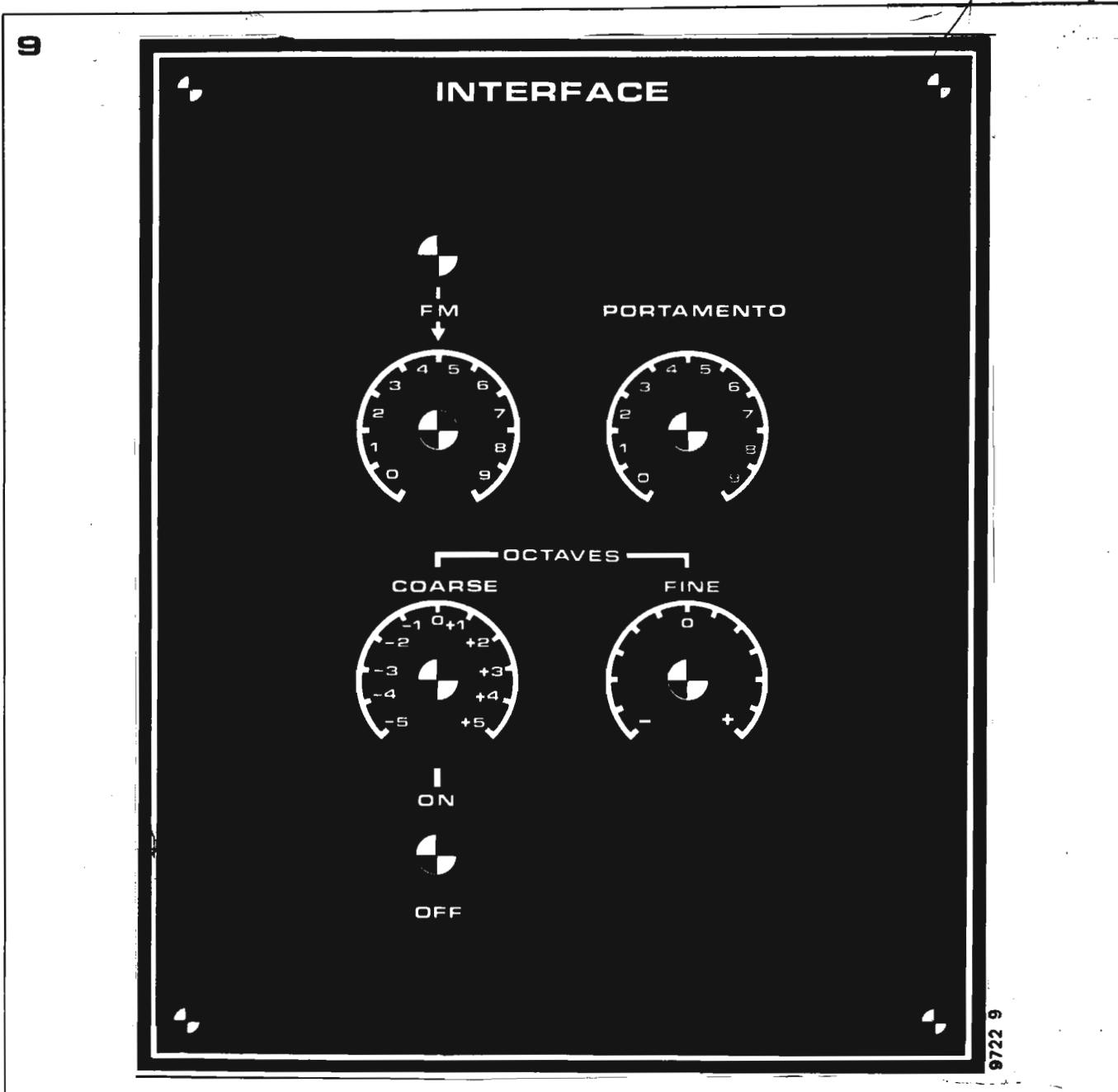

Figure 8. a: Dimensions of the keyboard case.  
 b: Exploded view of the keyboard case.

Figure 9. Interface board control panel.

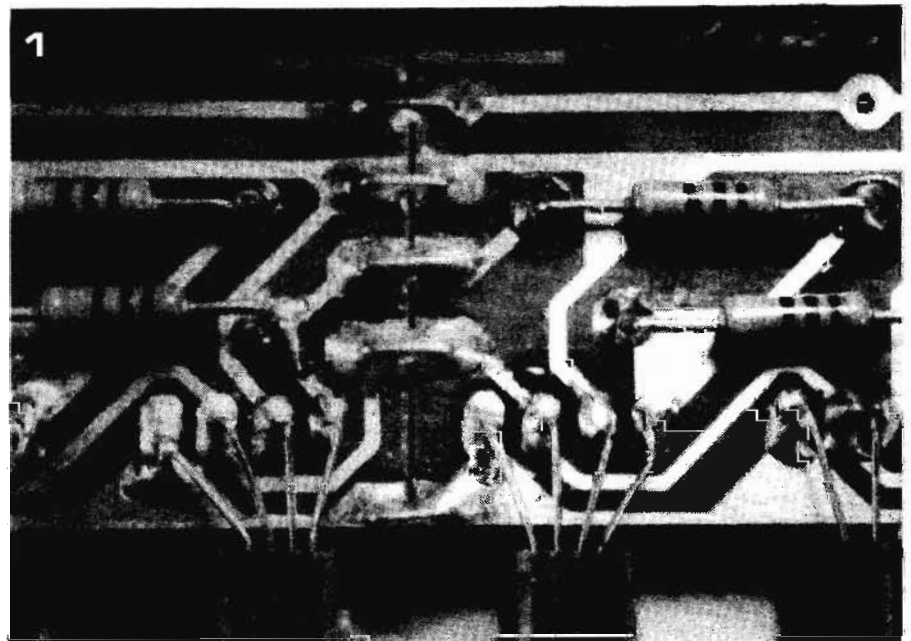
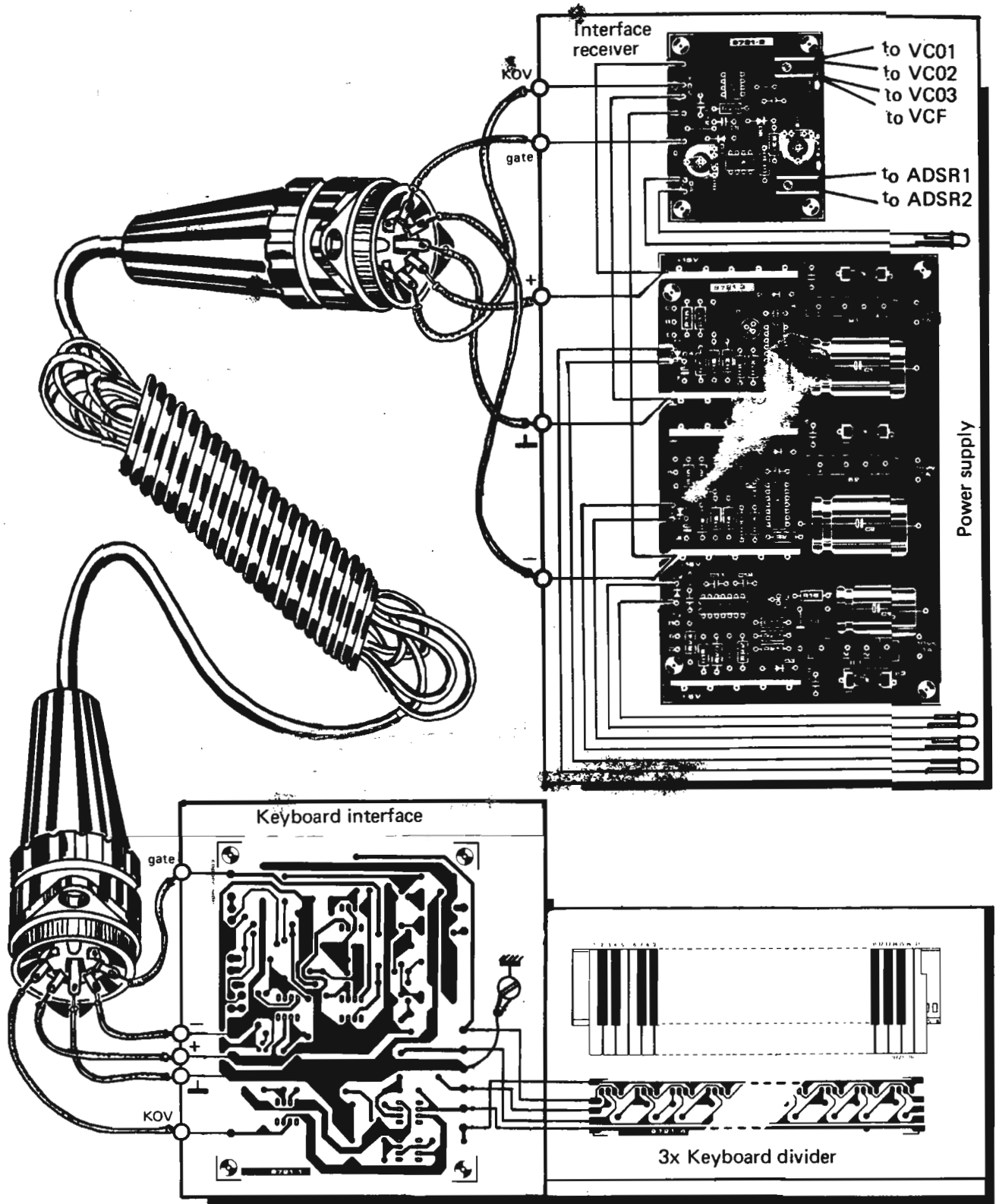

Photo 1. Showing the wiring of the key contacts to the keyboard divider p.c.b.

10



11

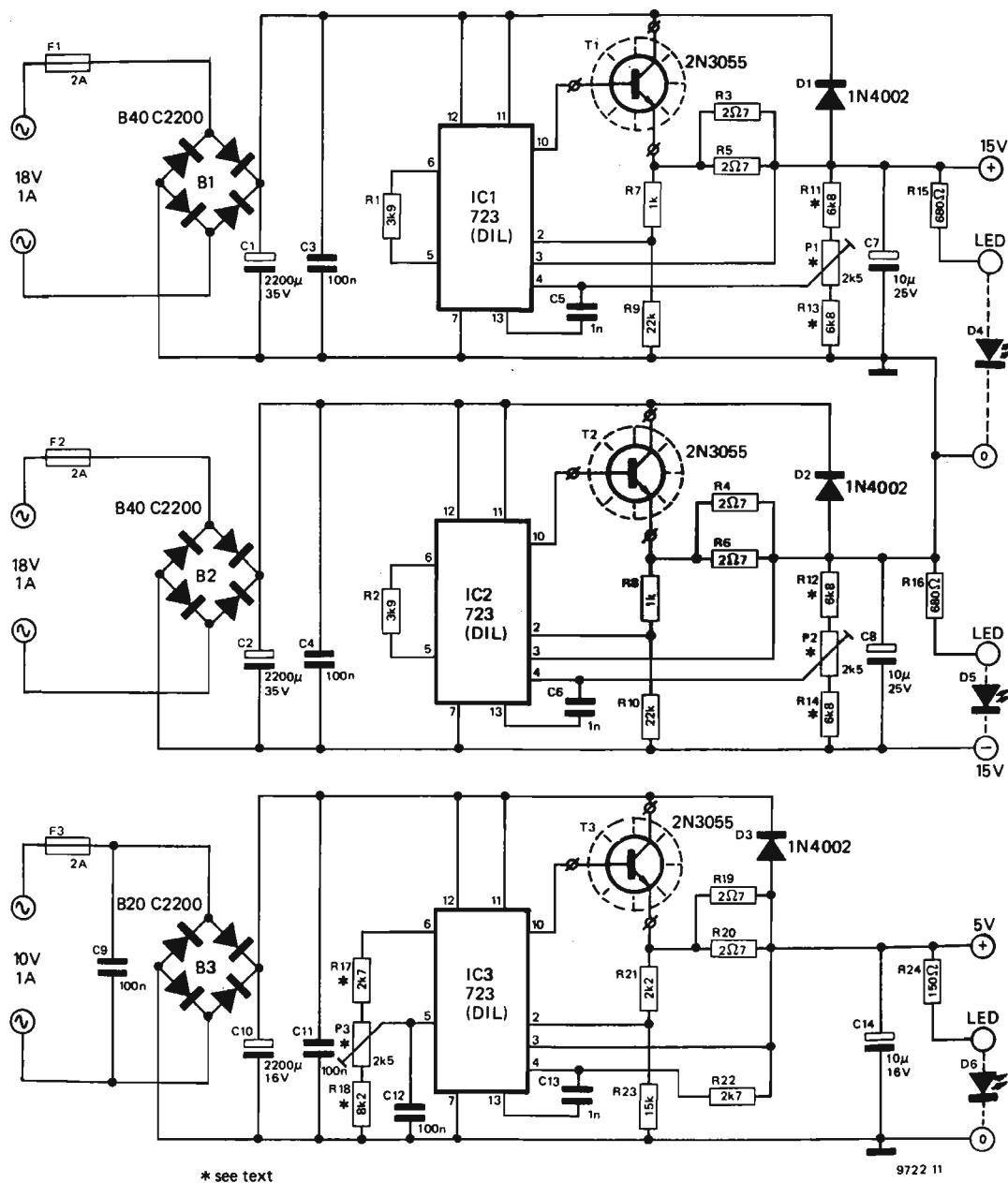
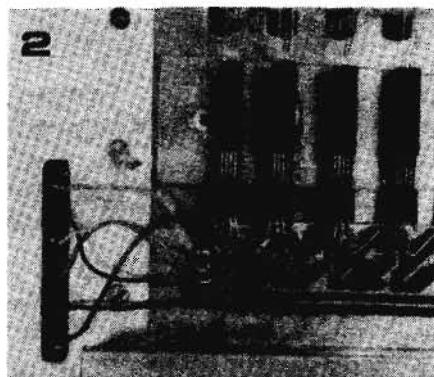

Figure 10. Showing the wiring between the keyboard unit, interface receiver and power supply.

Figure 11. Circuit of the Formant power supply.

Photo 2. Detail of the wiring between the keyboard divider and the interface board.

Although the keyboard unit is now a single assembly it still requires a case to house it, and the dimensions of a suitable case are given in figure 8a. The materials should be chosen to suit the type of use (or abuse) to which the synthesiser will be subjected, and the choice is left to the individual constructor. However, the dimensions given in figure 8a are based on some assumptions,



and if other materials are used the dimensions may have to be adjusted accordingly. The assumptions are that the baseboard is made of 10 mm plywood; that the top panel is also made of fairly thick plywood (10 . . . 15 mm) so as to leave room for the potentiometers above the interface board; that the side panels are made of plywood no thicker than 15 mm.

Particular note should be taken of the two wooden spacers glued to the bottom. These are required for mounting the finished keyboard assembly in the case.

Figure 8b is an 'exploded view' of the complete assembly, illustrating several of the points mentioned above. For screening purposes the inside of the case should be completely lined with thin aluminium or copper sheet or foil, which must be connected to ground. A front panel layout for the interface controls is given in figure 9. This mounts directly over the interface board and

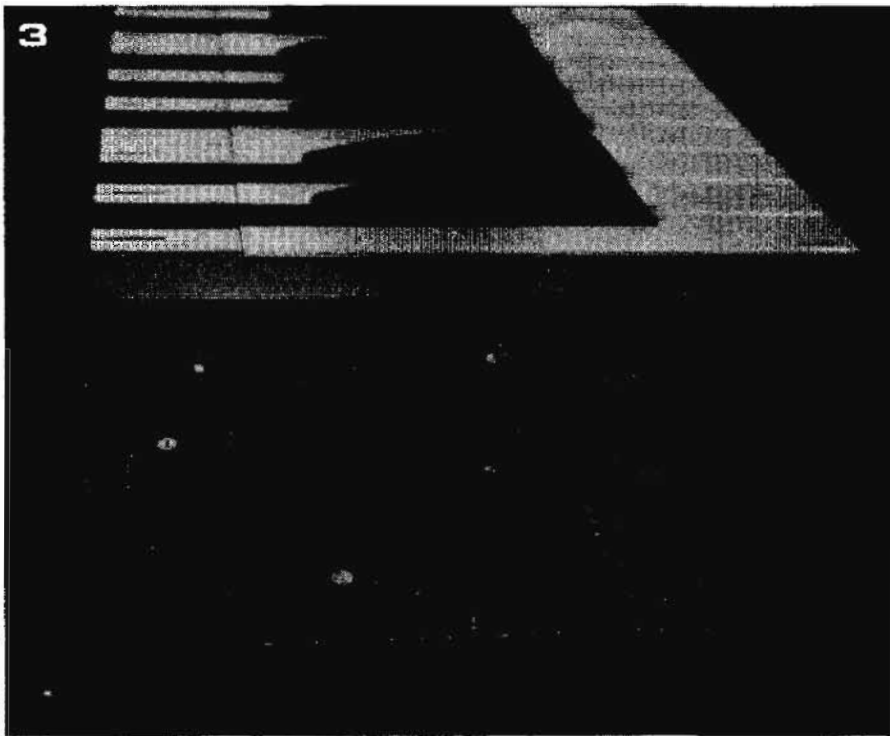

is secured to the keyboard case by four chromium-plated woodscrews.

Potentiometers P1, P2, P3 and P5 (portamento, FM, coarse and fine tuning) are mounted on the front panel, together with S1 and the FM input socket, which is a 4.5 mm jack. Connections between the front panel and the interface board should be made sufficiently long to enable the front panel to be removed without difficulty. If desired one edge of the front panel may be hinged for easy access to the interface board. The output and supply connections to the interface board are made by means of 5-pin DIN connectors, and a hole for the DIN socket should be cut in the side of the keyboard case adjacent to the interface board. The DIN-connectors should be high quality locking types, as the cheap

Photo 3. Showing the mounting of the interface board.

4

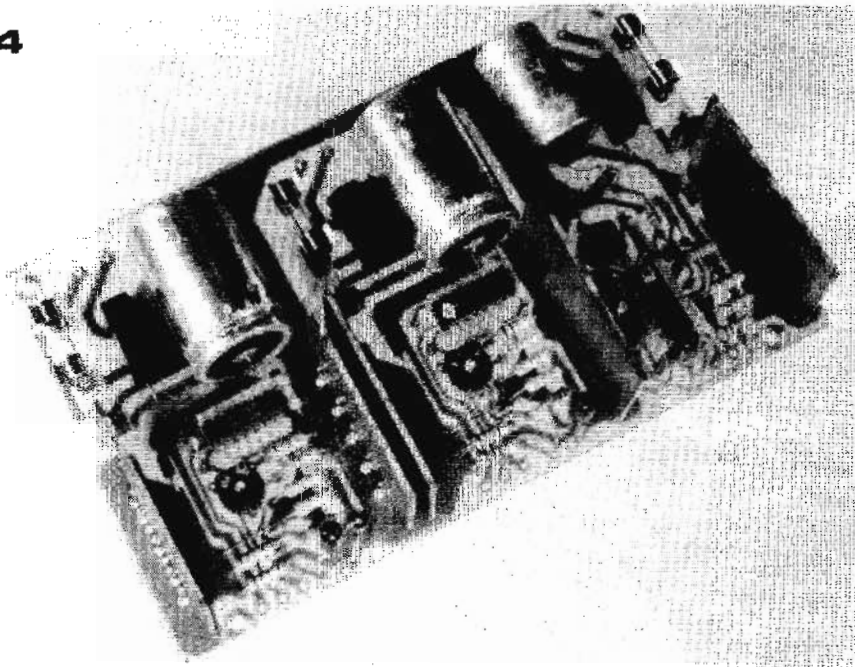

Photo 4. The completed power supply board.

plastic variety will quickly fail after repeated connecting and disconnecting. Connections from the interface board to the DIN socket are shown in figure 10.

### Power Supply

For final adjustment of the keyboard unit it is necessary to use the synthesiser's own power supply to ensure accurate setting of the volts/octave characteristic of the keyboard. For this reason the power supply circuit is now described.

Three output voltages are required for the synthesiser: +15 V, -15 V and +5 V. These must all be stable and easily adjustable, and for this reason all three supplies are based on the tried and trusted 723 precision voltage regulator IC. The circuit of the power supply unit is given in figure 11.

It will be noted that all three circuits are positive regulator circuits with an external power transistor to increase the output current. The -15 V supply is obtained simply by linking the positive output of this circuit to ground. This does have the slight disadvantage that separate transformer windings and rectifiers are required for each 15 V supply, but it does mean that both the positive and negative supplies are of identical design.

Each supply is equipped with foldback current limiting, and can comfortably supply over 800 mA, which should be adequate for any possible extension of the synthesiser. When limiting occurs (at about 1.2 A) the output voltage will fall and the current will fold back to about 500 mA with a short-circuited output. Current limiting of any of the outputs is indicated by the extinction of the LED indicator connected across that output.

A printed circuit board and component layout for the power supply unit are given in figure 12, and it should be noted that the output connections to T3 are different from those of T1 and T2, being arranged B-E-C instead of C-B-E. Good quality components should be used in the construction of the

Figure 12. Printed circuit board and component layout for the power supply (EPS 9721-3).

12

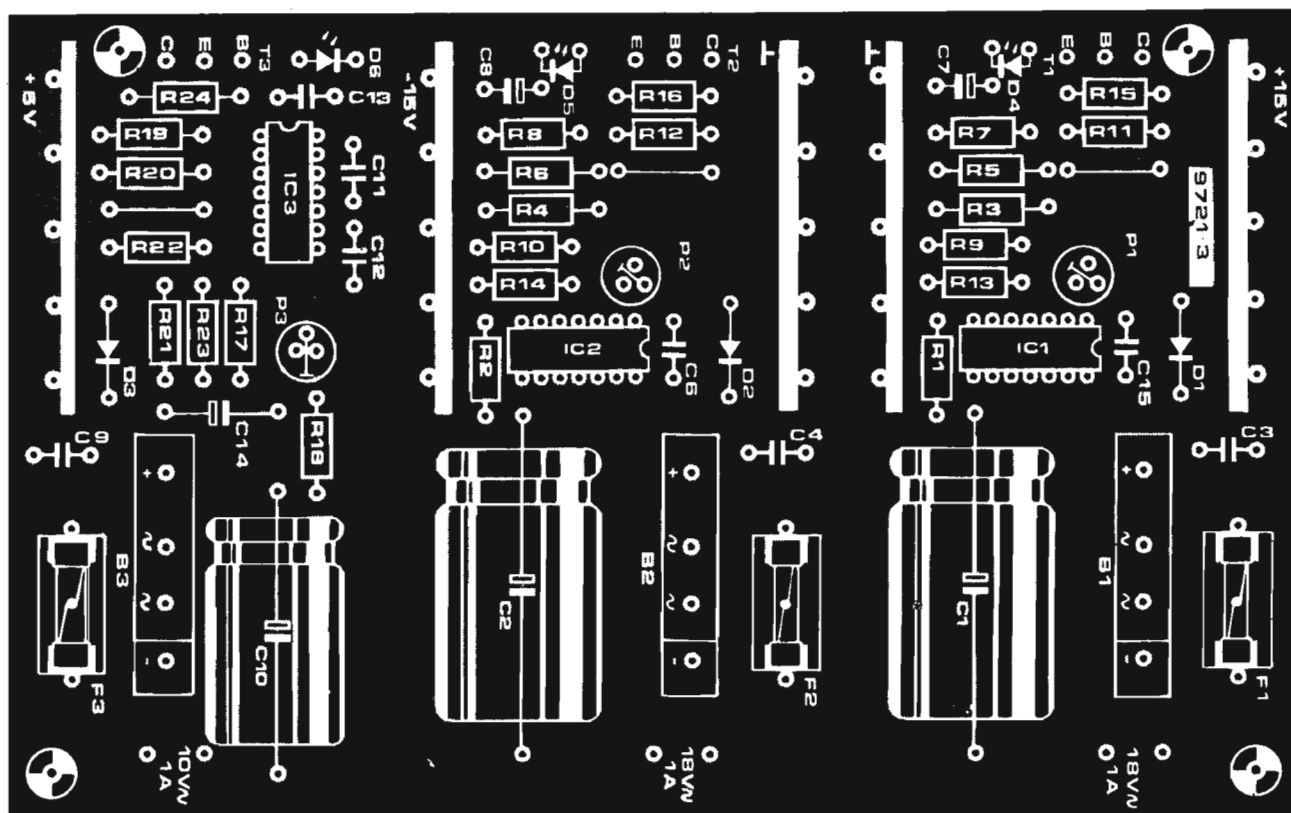
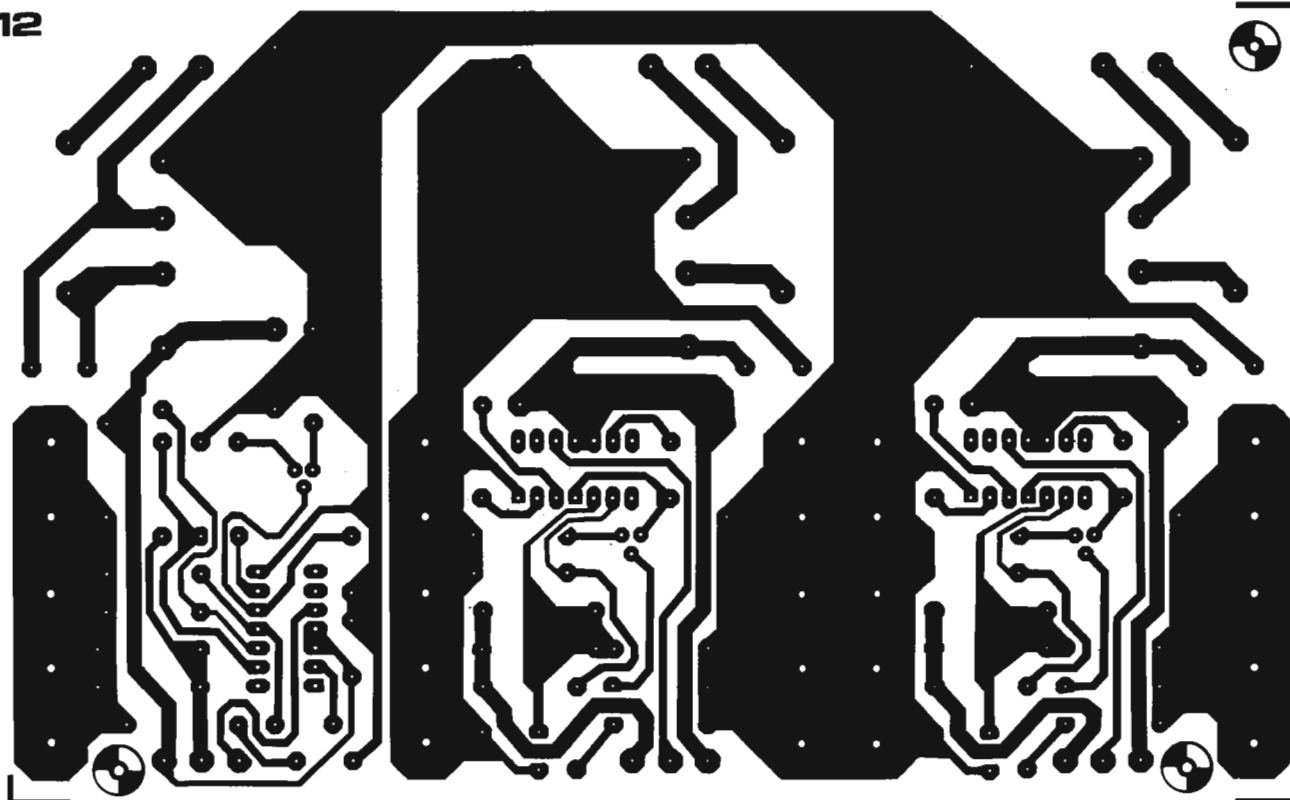

Parts List to figure 12

Resistors:

- R1, R2 = 3k9
- R3, R4, R5, R6, R19, R20 = 2Ω/7/0.5 W
- R7, R8 = 1 k
- R9, R10 = 22 k
- R11, R12, R13, R14 = 6k8 (2% metal oxide)
- R15, R16 = 680 Ω
- R17 = 2k7 (2% metal oxide)
- R18 = 8k2 (2% metal oxide)
- R21 = 2k2
- R22 = 2k7
- R23 = 15 k
- R24 = 150 Ω

Presets:

- P1, P2, P3 = 2k5 miniature (7 mm) cermet

Capacitors:

- C1, C2 = 2200 μ/35 V
- C3, C4, C9, C11, C12 = 100 n
- C5, C6, C13 = 1 n
- C7, C8 = 10 μ/25 V tantalum
- C10 = 2200 μ/16 V
- C14 = 10 μ/16 V

Semiconductors:

- D1, D2, D3 = 1N4002

D4, D5, D6 = LED (e.g. TIL 209)

- T1, T2, T3 = 2N3055
- IC1, IC2, IC3 = 723 (DIL)
- B1, B2 = 40 V 2.2 A bridge rectifier B40/C2200
- B3 = 20 V 2.2 A bridge rectifier B20/C2200

Miscellaneous:

- F1, F2, F3 = 2 A slow blow fuse
- Transformer(s) with 18 V, 18 V and 10 V secondaries at 1 A
- 3 Heatsinks approx 100 mm x 50 mm with 30 mm fins

power supply and the power transistors should be mounted on generous heat-sinks, for example finned heatsinks of 100 mm x 50 mm with 30 mm high fins. The AC supplies to the stabilisers may be provided by a single transformer with multiple secondary windings (if available) or by a number of smaller transformers. In either case the transformer(s) should be generously rated, the one amp secondary current specified being the minimum acceptable.

Power supply connections to the voltage-controlled modules will be taken from the power supply by separate wires to each module. For this reason each power supply rail is equipped with a substantial connection 'busbar'. These are made from copper strip or pieces of copper laminate board, and are soldered to terminal pins pushed through the p.c. board. This arrangement can clearly be seen in photo 4.

Once the power supply unit has been built the output voltages can be set to their correct values. The -15 V supply should be adjusted to within 1% of its nominal value using a DVM, since the accuracy of this supply voltage has a direct bearing on the volts/octave characteristic of the keyboard. The +15 V and +5 V supplies need only be set to within 3% of their nominal values.

**Keyboard calibration**

Once the synthesiser's own power supply has been tested and adjusted the offset compensation and volts per octave

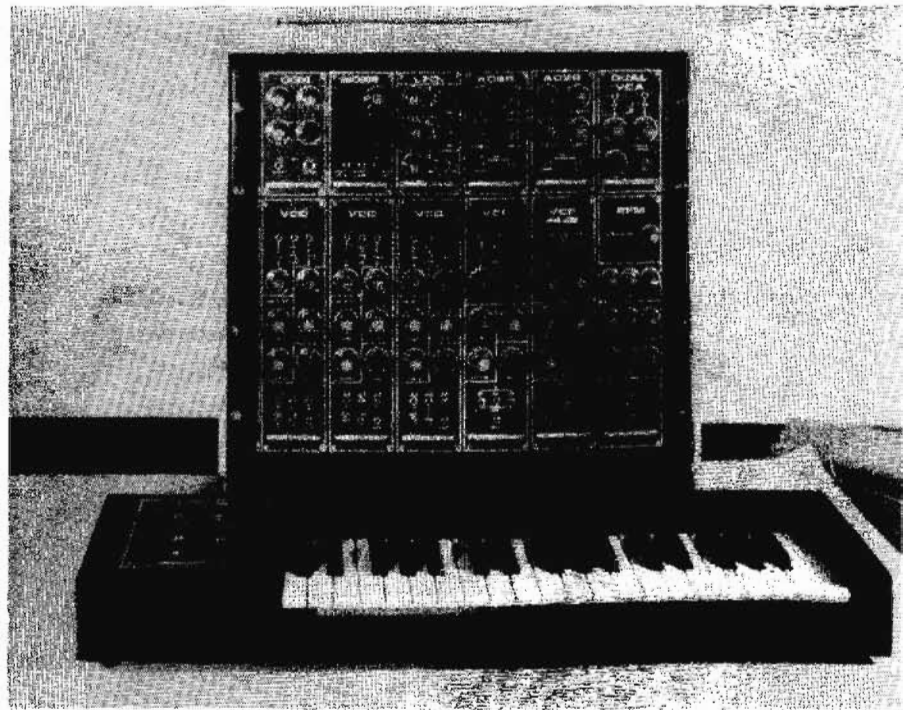

Figure 13. A suggested layout for a 'basic' synthesiser.

Figure 14. The dimensions of the Formant modules are compatible with the Eurocard rack system.

characteristic of the keyboard can be adjusted. The keyboard interface, interface receiver and power supply are connected as shown in figure 10.

**Offset compensation**

The overall tuning is switched off (S1 'off', i.e. position b). Depress the lowest key of the keyboard and hold it down while adjusting P4 so that the KOV output of the interface receiver is zero.

**Volts/octave characteristic**

This should be adjusted to an accuracy

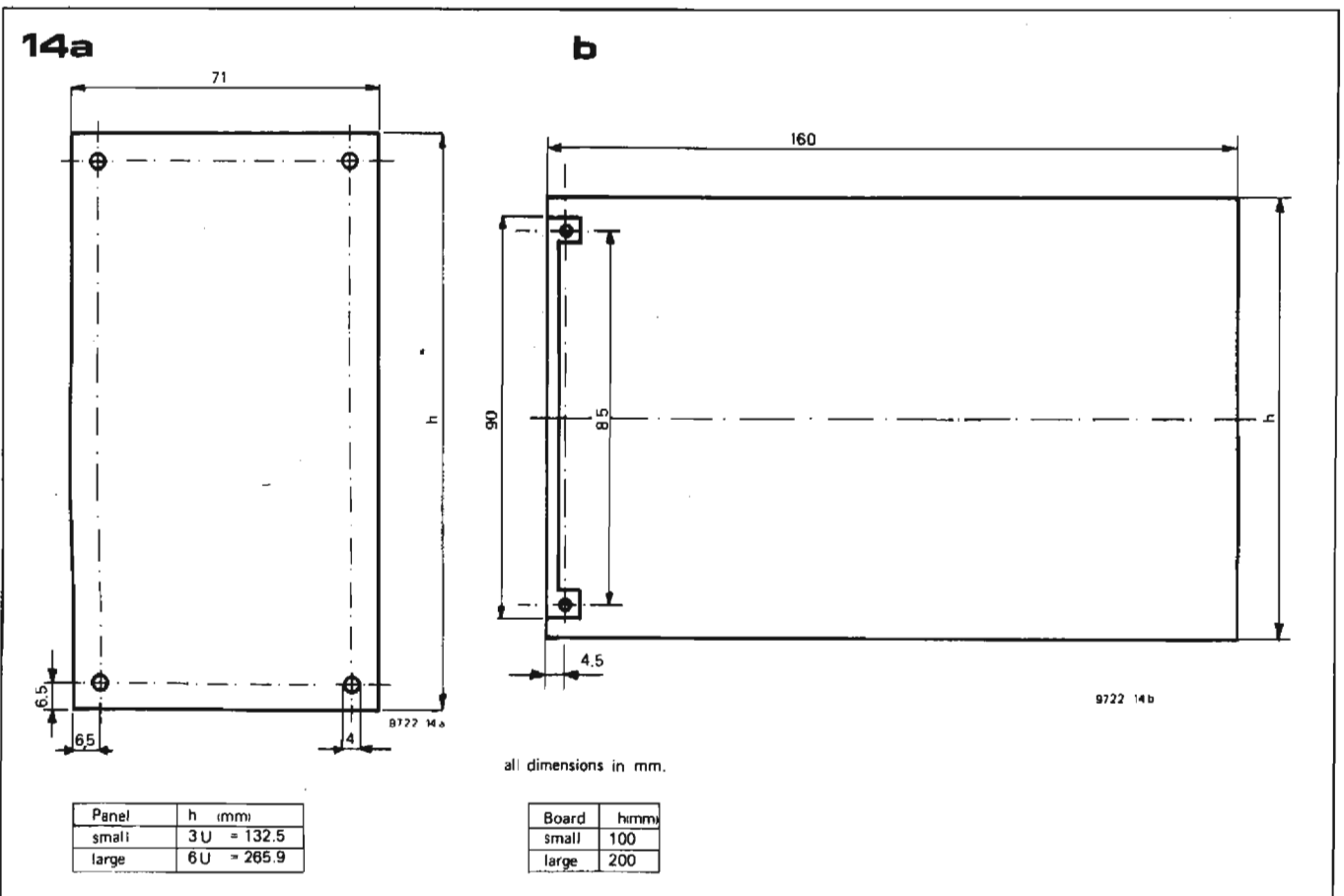
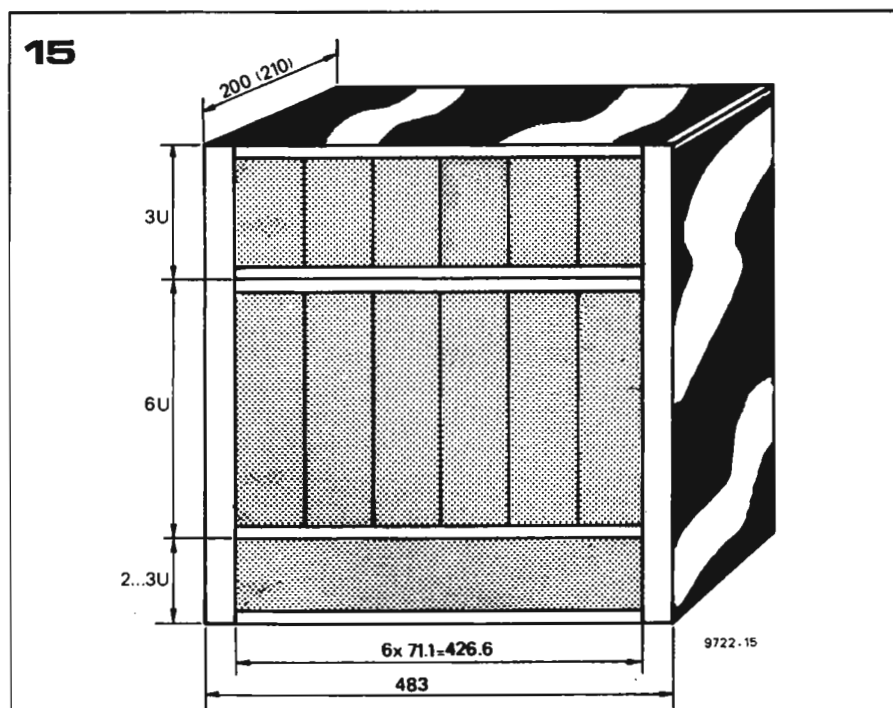

Figure 15. A case containing one 6U and one 3U rack will accommodate six large and six small Formant modules. It can be useful to add a 2U or 3U bottom panel (using a larger case!), behind which amplifiers etc. can be mounted.



of at least 1% using a DVM. The overall tuning remains switched off. The KOV output is measured and P6 is adjusted so that alternately depressing keys one octave apart causes the KOV output to change by exactly one volt. The Formant keyboard is now compatible with any synthesiser that uses a standard 1 V/octave keyboard.

Finally, the offset compensation should again be checked and readjusted if necessary.

#### Gate delay

Accurate adjustment of the gate delay is not possible until the voltage controlled modules have been constructed, but an approximate adjustment will suffice until that time. P7 on the interface board should be set to about one quarter of its maximum resistance, and P8 on the receiver board should be set to minimum.

#### Modular construction

A modular method of construction was chosen because it allowed the greatest flexibility in the final design. Each voltage-controlled circuit is constructed on its own p.c. board which plugs into a socket in the module housing that supplies power, control voltage and gate pulses. Interconnections between modules are made by means of patch cords.

The advantage of this system is that the synthesiser can be made as simple or as complex as is required. Provided sufficient space is left in the module housing for additional modules, it is possible to build a playable instrument with just a small number of modules, and to extend it as and when desired. This also means that every instrument can be tailored to the individual constructor's taste and is not fixed within

rigid limits set by the designer. However, for those who require a little more guidance as to the right 'mix' of modules that should be adopted, a suggestion for a 'middle-of-the-road' instrument is given in figure 13. This utilises three VCOs, one 12 dB VCF, one 24 dB VCF, one RFM, one DUAL VCA, two ADSR envelope shapers, one LFO module, one NOISE module and one COM. Some readers may regard the extra (24 dB) VCF and RFM as slight luxuries, and indeed for the beginner or someone with a slightly limited budget, these modules could be initially omitted. However they do considerably enhance the tone-shaping capabilities of the Formant, and for this reason can justifiably be included in the 'basic' Formant system.

The module printed circuit boards and front panels are compatible with the Eurocard rack system. Two module heights are employed in Formant. A double-height (6U) module is used for the voltage-controlled modules (VCO's, VCA's and VCF's) while a single-height (3U) module is used for the ancillary circuits (envelope, shapers, noise generator etc.).

The basic dimensions of the modules are given in figure 14. The Eurocard rack system operates on a card spacing of 5.08 mm (0.2") or multiples thereof. Each Formant module occupies a panel width of approx. 71 mm, so the 426.7 of panel width available will accommodate six modules. A 6U rack and a 3U rack stacked together will thus accommodate six large and six small modules, as shown in figure 15. This corresponds exactly to the no. of modules in the 'basic' Formant system.

Of course some readers, especially those with previous experience of synthesisers, may already have a firm idea of the type of instrument they wish to build, and may like to construct a purpose-

built case of wood or some other material. This is quite permissible, as the module housing does not require screening.

## chapter 4

### voltage controlled oscillator

The voltage controlled oscillators (VCOs) are the heart of any synthesiser. The quality of the VCOs ultimately determines the performance of the synthesiser. For this reason the next two chapters are devoted to their design and construction.

The two principal requirements of a synthesiser VCO are stability and good tracking. Stability means that if the control voltage applied to the VCO remains constant, then the frequency of the VCO should also remain constant and not drift. Tracking means that the VCO must follow the prescribed logarithmic 1 octave/V characteristic as closely as possible. In particular, where several VCOs are used they should all have similar characteristics.



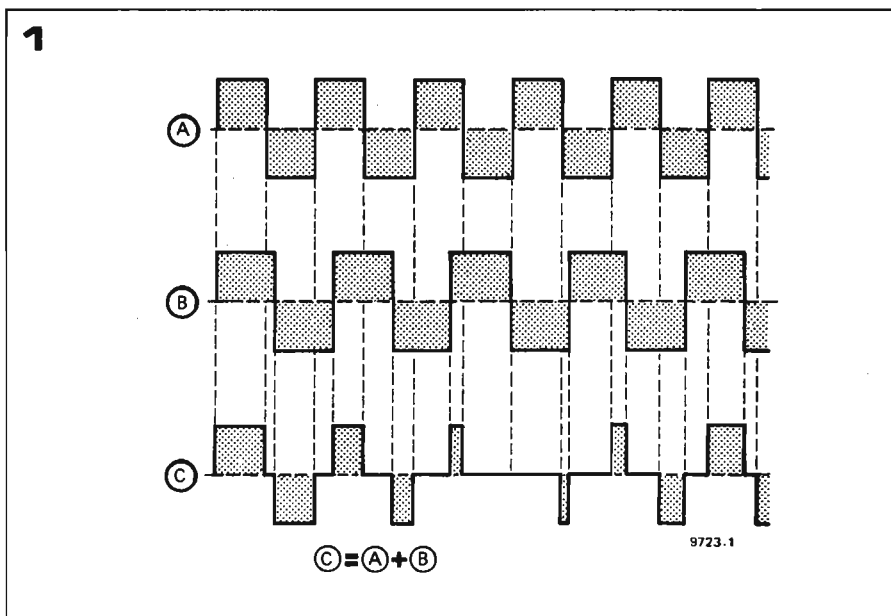

These parameters are particularly important in a chording instrument such as the Formant, where a number of VCOs are used simultaneously. In a synthesiser using only one VCO slight drift or deviation from the 1 octave/V characteristic might not be noticed, since the ear is not particularly good at judging absolute frequency, unless a person has 'perfect pitch'. In any chording instrument however, even slight mistuning is immediately apparent due to the formation of beat notes.

For example, if two or more VCOs are tuned to the same pitch any slight mistuning is audible as beat notes having a frequency equal to the difference between the two VCO frequencies. Slight mistuning between VCOs is frequently employed deliberately. If the degree of mistuning is slight the beat frequencies are low and beat notes are not audible, but a pleasing chorus or

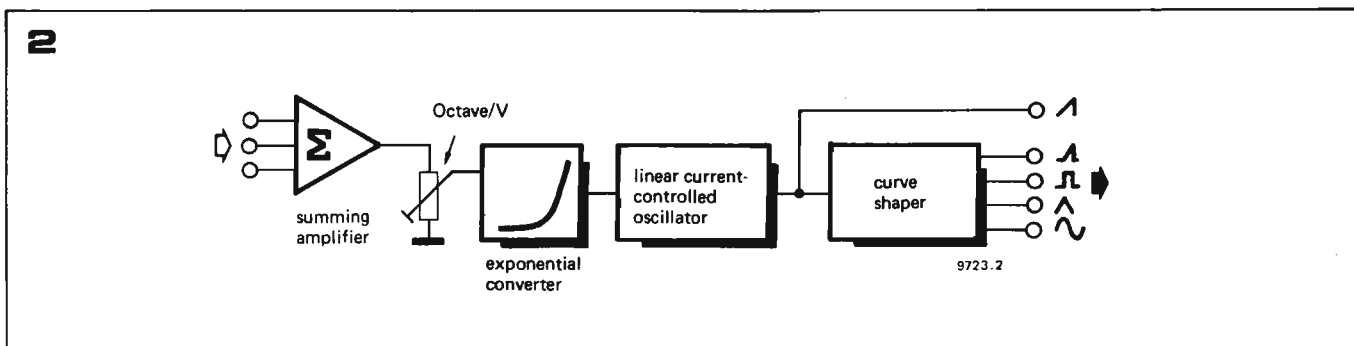

Figure 1. When two notes of almost the same frequency are played together, beat notes are formed which produce a pleasing 'chorus' effect.

Figure 2. Block diagram of the VCO, which comprises an input summing amplifier, exponential voltage-current converter, linear current controlled oscillator and curve shaper circuits.

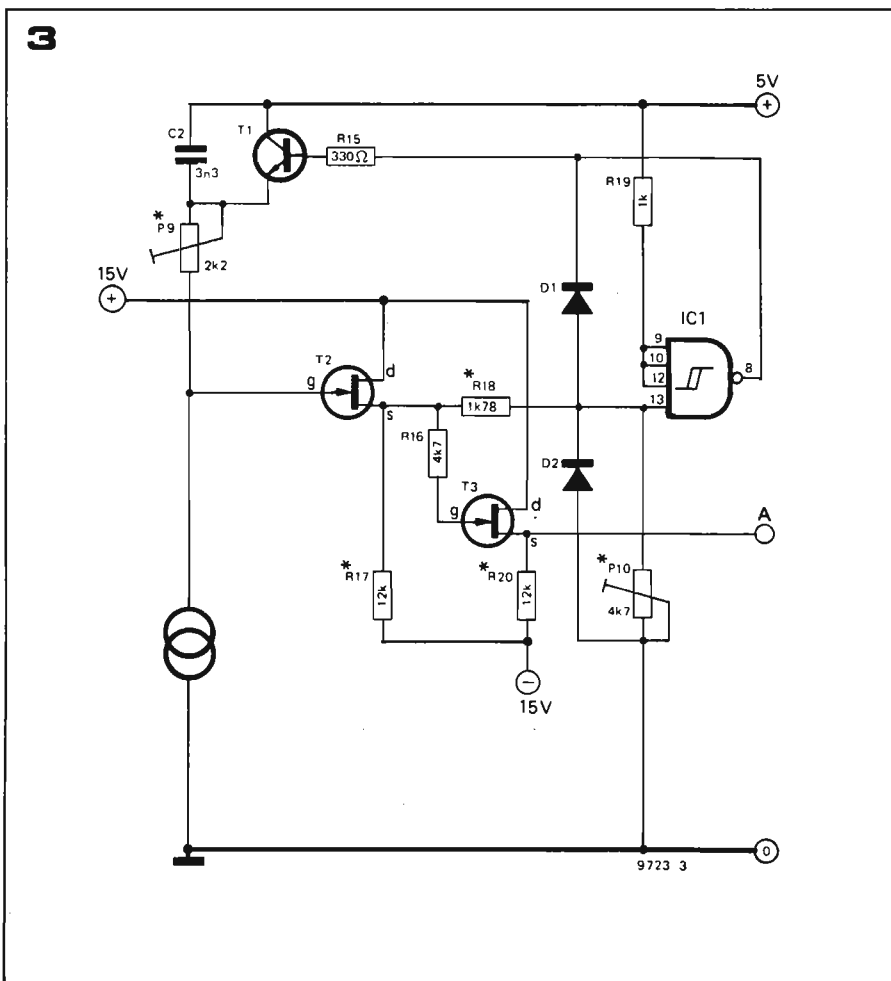
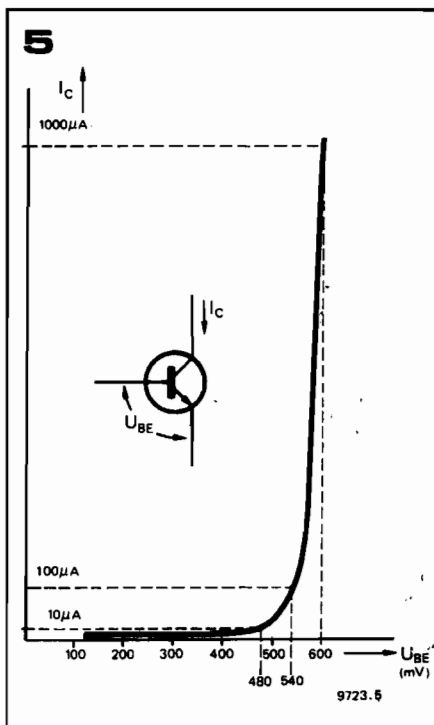
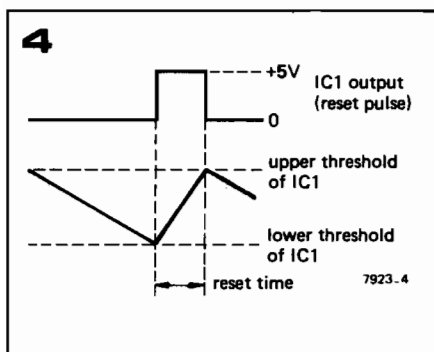

Figure 3. The linear CCO is the heart of the VCO module. C2 charges linearly to the lower threshold of IC1 before being discharged by T1, thus producing a sawtooth output waveform. The output of the exponential converter, which determines the charging current and hence the CCO frequency, is represented by the current source symbol.

Figure 4. Detail of the sawtooth waveform and the output of IC4 at the reset point where T1 is turned on.

Figure 5. The exponential relationship between base-emitter voltage and collector current of a bipolar transistor is exploited in the exponential generator.



phasing effect is obtained, especially if several VCOs are used. This imparts a much more lively character to the sound which contrasts with the sterile sound of fixed phase instruments such as electronic organs based on a divider system (see figure 1).

However, if the VCO frequencies drift apart due to poor stability the beat notes quickly become obtrusive and unpleasant, and ultimately a discord is audible. A similar effect can be noted when the tracking of the VCOs is poor. If a chord is set up at a particular pitch then the musical intervals in the chord should be maintained when the chord is transposed to a different pitch. However, if the tracking of the VCOs is poor this will not be the case and a discord will result.

A good test of the VCOs in a synthesiser is thus to tune them together so that no beat notes are audible and check that the tuning is maintained over a period of time and with changes in such parameters as supply voltage, temperature etc. The tuning between the VCOs should also be maintained when the pitch is transposed.

Any VCO which cannot meet these criteria is useless for a synthesiser, and the design of a suitable synthesiser VCO is necessarily quite complex.

## Block diagram

The VCO circuit used in the Formant follows the form proposed first by Robert Moog (figure 2). The VCO input stage consists of a summing amplifier into which a number of control voltages may be fed. A potentiometer on its output sets the octaves/volt characteristic of the VCO. The resulting control voltage is fed to an exponential voltage-current converter, the output current of which doubles for every 1 V rise in input voltage. The output of this converter controls a linear current-controlled oscillator, which produces a sawtooth waveform. Finally, a curve shaper connected to the sawtooth output delivers four further waveforms: spaced sawtooth, squarewave, triangle and sinewave.

## Oscillator section

The CCO is the heart of the VCO circuit, as explained above.

The CCO section is shown in figure 3. The output of the exponential voltage-current converter that feeds this section is represented by the current source symbol at the bottom left of the diagram. This current is of course varied by the control voltage applied to the exponential converter.

FETs T2 and T3 are connected as source followers; their high input resistance ensures that no significant current is robbed from the current source, even at low currents, as this would spoil the sawtooth linearity and could affect the current-frequency linearity of the CCO. IC1 is a Schmitt trigger that senses when the sawtooth voltage has reached a predetermined level.

The circuit functions as follows: assume that initially C2 is discharged. The voltage at the gate of T2 will then be nearly +5 V, and since T2 operates as source-follower the voltage at the input of IC1 will be above the positive trigger threshold of this Schmitt trigger, so its output is low and T1 is turned off. As C2 charges from the current source the gate voltage of T2 will fall as the voltage across the capacitor increases. Since C2 is being charged from a constant current source, the voltage across it will increase linearly with time, in accordance with the equation

$$U_{C2} = \frac{I \cdot t}{C_2}$$

When the voltage at the input of IC1 has fallen below its negative switching threshold the output of IC1 will go high, which will turn on T1 and discharge C2 until the input voltage of IC1 has risen above its positive threshold, when T1 will turn off and the whole cycle will repeat. A detail of the IC1 output and input waveforms during the discharge of C2 is shown in figure 4.

FET T3 is simply an output buffer stage. As mentioned earlier, the use of two buffer stages in cascade ensures that any load on the output cannot affect the

linearity or frequency stability of the CCO.

The setting of P9 affects the high-frequency linearity of the CCO and is used to set the VCO tracking at high frequencies.

Since N-channel FETs are used for the source-follower buffers, the source voltage is always slightly positive with respect to the gate voltage, so that even when the gate of T2 is at zero volts there is always a slight positive voltage on the source. If the source of T2 were connected direct to the input of IC1 it would be possible that the source voltage of T2 (minimum, depending on FET tolerances, typically 1 V) might never fall below the negative threshold of IC1 (typically 0.85 V). For this reason T2 is connected to the input of IC1 via a potential divider comprising R18 and P10, the latter being adjusted to ensure that the oscillator starts reliably.

## The exponential converter

The exponential voltage-current converter doubles the output current fed to the CCO, and hence the CCO frequency, for every 1 V increase in control voltage.

In common with most such circuits, the exponential converter makes use of the (exponential) collector current versus base-emitter voltage characteristic of a bipolar transistor. Every transistor exhibits this exponential relationship, but not all transistors are suitable for use in exponential circuits. The reason is that collector leakage current can cause a deviation from the characteristic at low collector currents, and transistor base resistance can cause a deviation at high collector currents.

Special transistors for such applications are available, but even these have their limitations due to temperature dependence of the collector current. At around room temperature, collector current doubles for a  $V_{be}$  increase of around 17 mV. However, a temperature increase of around  $10^\circ C$  will also double the collector current, so it is apparent that, unless some form of temperature compensation is employed, even small temperature changes will cause noticeable variations in the pitch of the VCO.

There are two methods of reducing the influence of changes in (ambient) temperature, both of which are used in the Formant VCO. The first of these is to use a matched pair of transistors in the exponential converter, one of which is used for temperature compensation. The second method is to keep the chip temperature of the transistors constant. By employing both methods absolute accuracy and stability of the exponential converter are achieved. Temperature stabilisation of the chip may sound like a complicated business, but fortunately a purpose-built IC is available, the  $\mu A726$ . It consists of two matched NPN transistors and also contains a tempera-

6

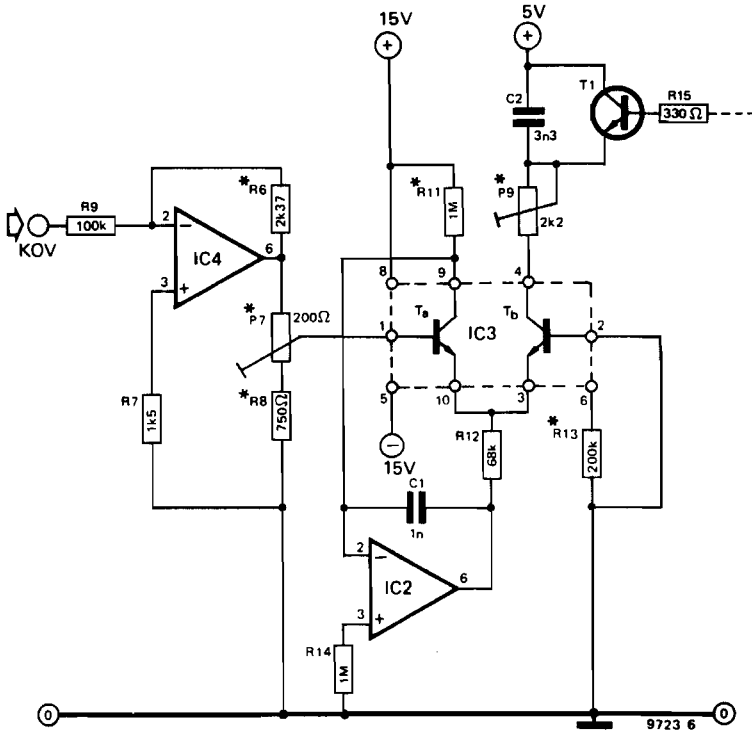

Figure 6. Circuit of the exponential voltage-current converter, which is both temperature stabilised and compensated. IC4 and T1 are respectively parts of the input adder circuit and the CCO.

Figure 7. Complete circuit of the input adder. This will sum input control voltages from the keyboard or ECV socket, DC offset voltages for chording, and AC input signals for frequency modulation of the VCO.

Figures 8 and 9. The musical quality of a waveform depends on the harmonic content. The harmonic structure of two well-known waveforms is shown: sawtooth (figure 8) and squarewave (figure 9). In order to obtain the widest range of sounds from the Formant VCO, curve shaper circuits are provided that produce four waveforms in addition to the basic sawtooth.

Figure 10. Block diagram of the curve shaper. An output adder allows the various waveforms to be fed to the output either individually or in combination.

ture control circuit that maintains a constant chip temperature.

The circuit of the exponential converter is given in figure 6. IC4 is not strictly part of the converter but is part of the summing amplifier section. At the operating temperature of the 726 a  $V_{be}$  increase of between 19 and 23 mV is

required for each doubling of collector current, so the 1 V/octave output of the keyboard must be attenuated.

IC4 is connected as an inverting amplifier with a gain of  $-0.0237$ . Since the KOV input is always positive the output of IC4 will always be negative, and will give an output of  $-23.7$  mV per volt

input. P7 allows the input voltage to the exponential converter to be varied between  $-18.7$  and  $-23.7$  mV per volt input, in order to compensate for tolerances in IC3.

The exponential converter proper comprises IC2 and IC3. The non-inverting input of IC2 is grounded through R14, so the inverting input should also be at (virtual) earth potential. For this to be the case, a constant current of  $15 \mu\text{A}$  must flow through R11, i.e. the collector current of  $T_a$  must be constant at  $15 \mu\text{A}$ . The voltage-to-current conversion can now be explained as follows.

If the input voltage KOV is increased by 1 V then the base voltage of  $T_a$  will fall by around 20 mV (depending on the setting of P7). Since the collector current of  $T_a$  cannot decrease the output voltage of IC2 must fall in order to reduce the emitter voltage of  $T_a$  by 20 mV, maintaining the same base-emitter voltage and thus the same collector current. As the base of  $T_b$  is grounded this means that the base-emitter voltage of  $T_b$  will fall by 20 mV, and the collector current of  $T_b$  will double. The collector of  $T_b$  is connected to P9 in the CCO circuit, as shown in the top right hand corner of figure 6.

### Summing amplifier

The summing amplifier, part of which was shown in figure 6, is given in its complete form in figure 7. Point KOV is permanently connected to the 1 V/octave output of the keyboard interface receiver, but the input of the summing amplifier can be switched between this point and an external

7

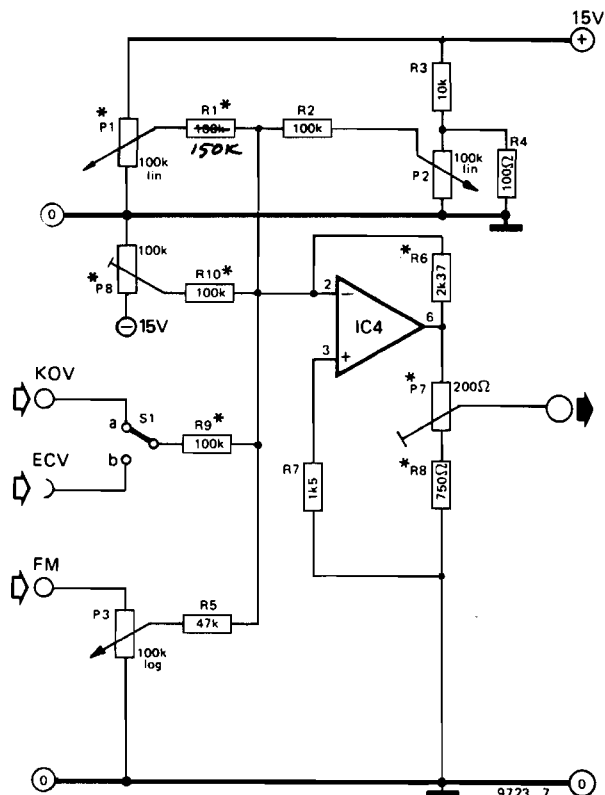

control voltage socket (ECV). Potentiometers P1 and P2 give coarse and fine adjustment of a DC offset voltage to transpose the VCO pitch for setting up chords etc. Preset P8 is also provided as an offset control that compensates for the input offset voltage of IC4, and sets the lowest frequency of the VCO (around 15 Hz).

A frequency modulation (FM) input is provided, which can be fed with external (AC) signals to give vibrato effects etc. The modulation depth can be adjusted by P3, the maximum sensitivity being about 2 octaves/V with P3 turned fully clockwise.

As previously mentioned, the summing amplifier actually has a gain much less than one, so that the output voltage of IC4 is reduced to  $-23.7$  mV per volt input.

### Curve shapers

Having ensured that the 'business end' of the VCO design is satisfactory, the design of the curve shaper section - which influences the musical characteristics of the VCO - may now be considered. The main processing of the synthesiser waveforms is done by means of voltage-controlled filters (VCFs) which remove certain frequencies from a harmonically rich waveform.

The spectra of two well-known harmonically rich waveforms are shown in figures 8 and 9 - the sawtooth, which contains all the odd and even harmonics of the fundamental, and the squarewave, which contains only the odd harmonics. However, this approach does have its limitations if only one waveform is provided at the VCO output. Using as an example the two waveforms just mentioned; no amount of filtering will generate the even harmonics necessary to turn a squarewave into a sawtooth, and it would be very difficult to filter out all the even harmonics from a sawtooth to make a squarewave. It is thus obviously useful to have several different waveforms available at the VCO output.

A block diagram of the curve shaper is shown in figure 10. The sawtooth output of the VCO is fed to curve shaper circuits, which produce respectively spaced sawtooth, triangle, sine and square waveforms. The pulse width of the squarewave may be modulated by an external control signal, as will be explained in the description of this part of the circuit.

The five waveforms may be selected by means of switches to be fed, either singly or in combination, into a summing amplifier.

### Musical properties of the waveforms

Each of the waveforms available at the VCO output has its own musical character, which is useful for particular applications. An unfiltered squarewave

8

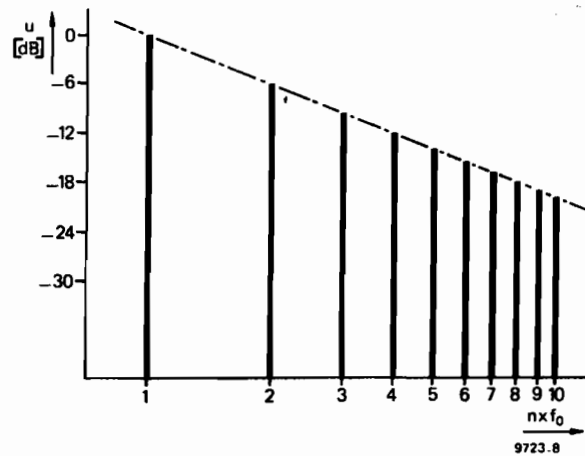

9

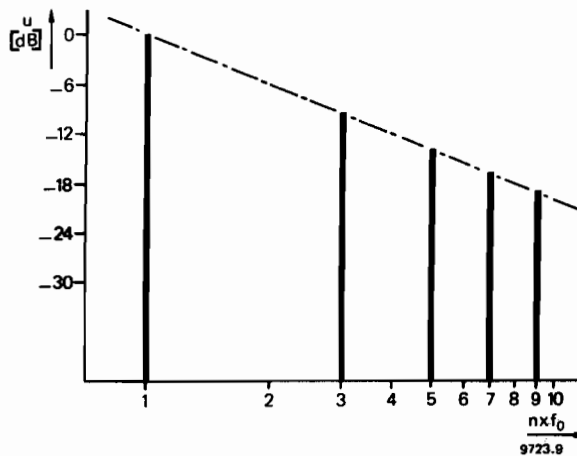

10

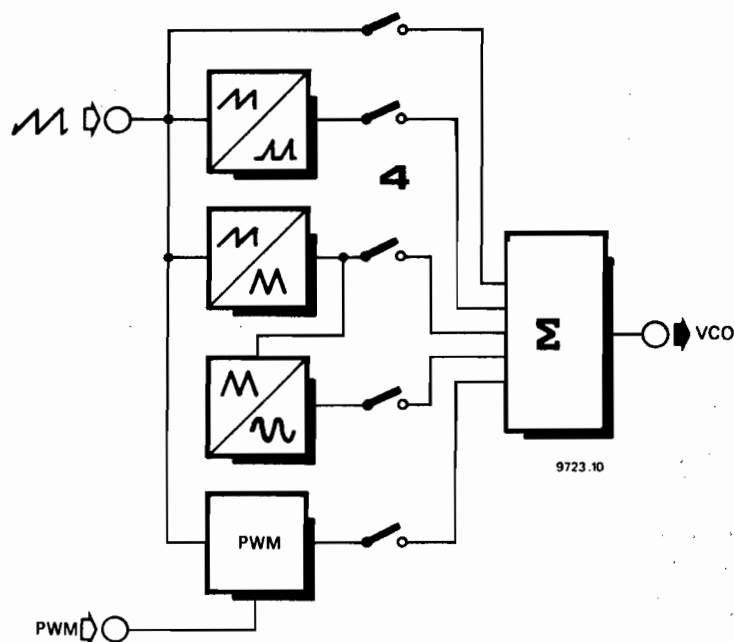

11a

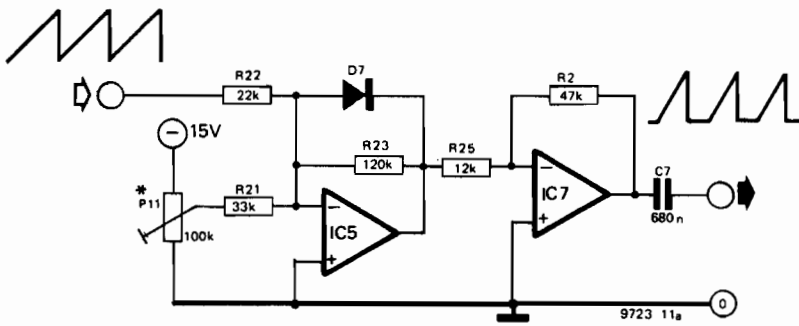

11b

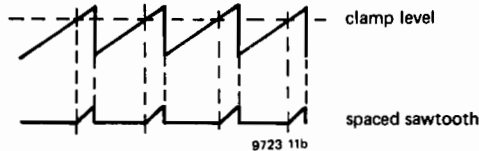

12

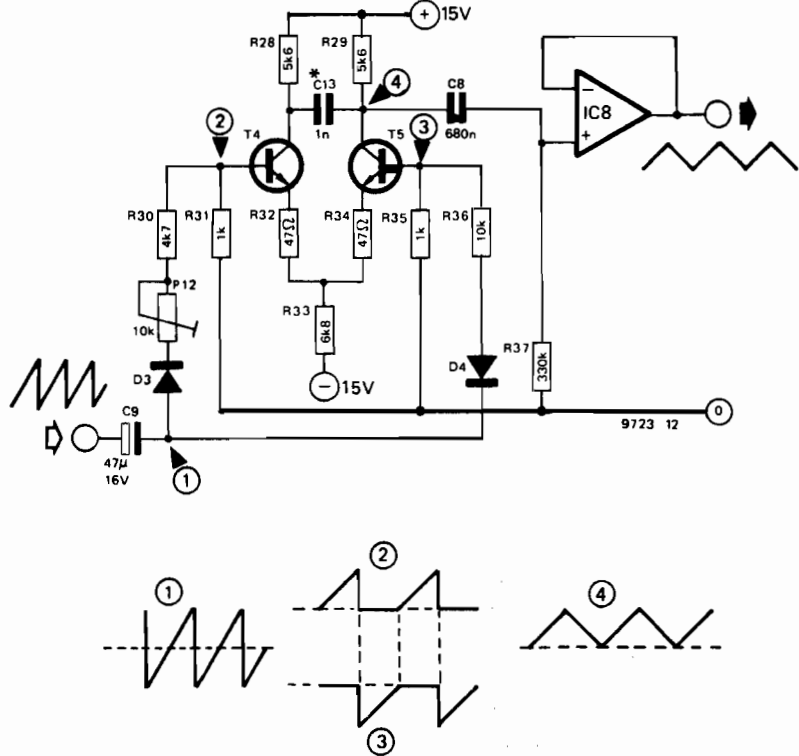

Figure 11. Circuit of the spaced sawtooth converter. This clips the sawtooth waveform, passing only the peaks.

Figure 12. The triangle converter operates by feeding the positive and negative half-wave rectified sawtooth to the inputs of a differential amplifier. The resultant difference output is a triangle waveform.

Figure 13. The sine converter operates simply by 'rounding off' the peaks and troughs of the triangle to give an approximation to a sinewave.

Figure 14. The PWM squarewave generator is simply a voltage comparator whose output switches at a certain point on the sawtooth waveform. The trigger level can be varied, either by P5 or by an external input, thus pulse width modulating the squarewave as shown in figure 14b.

Figure 15. The output adder, which can be used to combine the various output waveforms as desired.

A pure sine waveform is, of course, completely lacking in any harmonic content and sounds even smoother and more bland than the triangle - so far as to be completely without character. A low harmonic distortion of the sine waveform is not particularly important for musical applications, provided the harmonic content is sufficiently low that the sinewave sound contrasts with that of the triangle. The sinewave is thus derived from the triangle by an extremely simple diode shaper circuit.

13

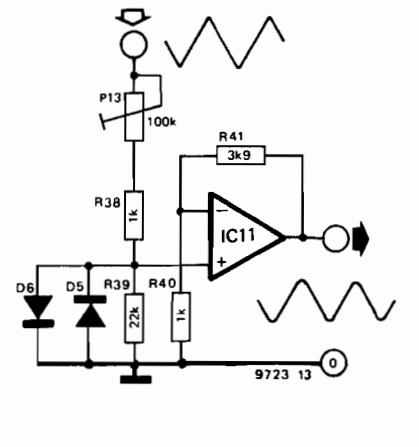

is not particularly useful, since the odd harmonics cause the sound to be extremely harsh. However, filtered squarewaves are useful for the imitation of flute tones, and certain woodwinds such as clarinet.

The sawtooth waveform, which is rich in all harmonics is suitable for the imitation of brass, woodwind and many string instruments, and has an extremely bright and lively character.

The amplitudes of the sawtooth harmonics fall off at 6 dB per octave, i.e. the amplitude of the nth harmonic is 1/n times the amplitude of the

fundamental. Where this fall is too abrupt the spaced sawtooth waveform can be used. This has an even brighter character than the sawtooth and is extremely useful for imitating very brilliant instruments such as the violin family and some of the higher pitched brass instruments such as cornet and trumpet.

The triangle and sine waveforms are musically very similar. The triangle is completely lacking in even harmonics, and the odd harmonics are of low amplitude. The sound of the triangle is flutelike, very smooth and mellow.

### Spaced sawtooth converter

Figure 11a shows the circuit of the spaced sawtooth converter section. The sawtooth output of the VCO is fed into IC5 via R22. IC5 functions as an inverting half-wave rectifier, with a variable offset provided by P11. Depending on the setting of P11, the negative voltage at its slider causes a positive offset at the output of IC5 of between zero and about +14 V.

While the output of IC5 is positive D7 is reverse biased and the op-amp amplifies and inverts the positive going input sawtooth with a gain of about 5.5. However, this applies only so long as the output of IC5 remains positive. As the sawtooth voltage increases, a point on the waveform will be reached where the output of IC5 falls below zero. D7 will become forward biased and will clamp the output of IC5 to about -0.6 V.

The point on the sawtooth waveform at which clamping occurs depends on the setting of P11. With P11 adjusted to give an offset of zero the sawtooth will be clipped at a very low level. On the other hand, with P11 set to give a large offset voltage the sawtooth amplitude may never be high enough to cause the output of IC5 to swing negative, and the sawtooth will appear at the output of IC5 unclipped.

IC7 amplifies and inverts the output from IC5 with a gain of about -4, and P11 is adjusted so that the amplitude is the same as that of the sawtooth waveform, nominally 1.5 V p-p.

### Triangle converter

Half-wave rectification is again employed in the triangle converter, figure 12. The input sawtooth (1) is positive and negative half-wave rectified by D3 and D4, and the positive and negative half cycles are fed to the bases of T4 and T5 respectively (2) and (3). Since T4 and T5 form a differential amplifier the collector waveform of T5 is (2) - (3), which is a triangular waveform (4). IC8 is connected as a voltage follower to buffer the output.

It may seem a little strange to use a discrete amplifier in this circuit when extensive use is made of IC op-amps

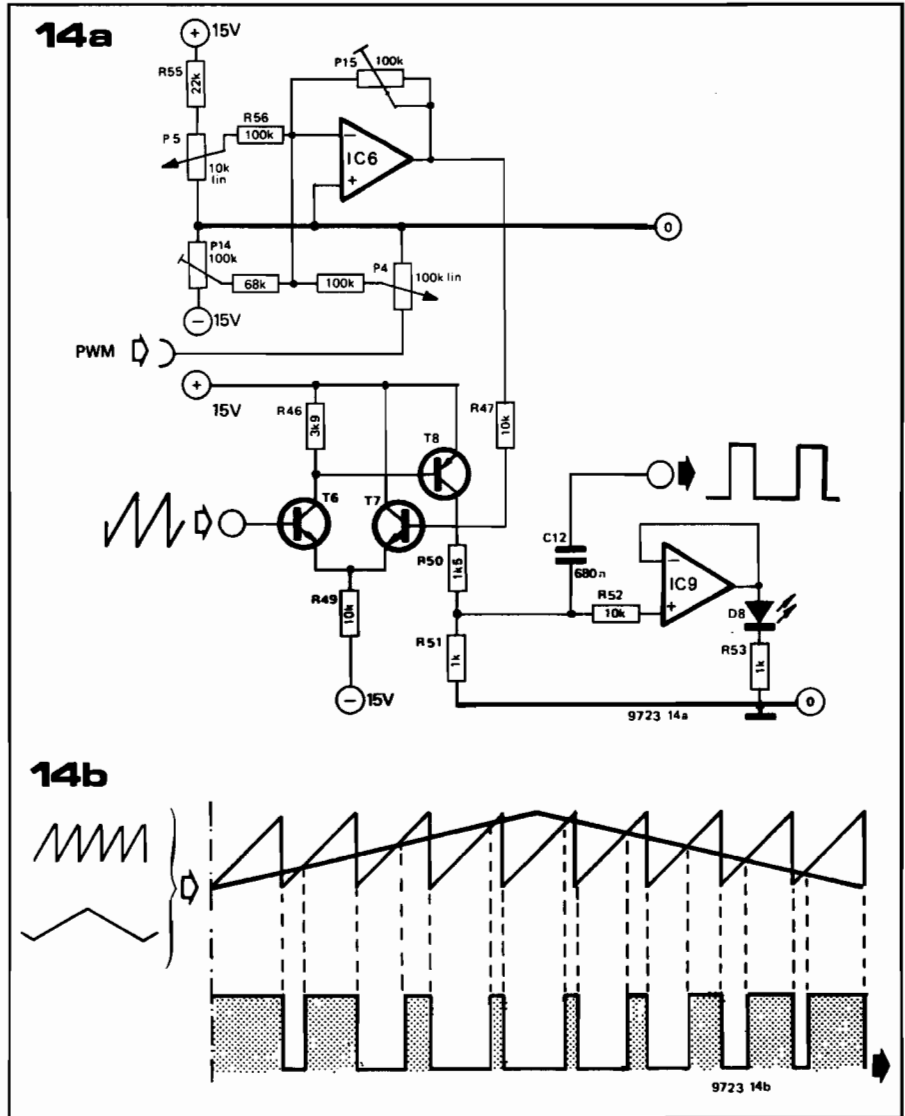

elsewhere. The reason is that they have a limited slew rate, and this can result in a notch at the apex of the triangular waveform where the crossover from positive half-cycle to negative half-cycle occurs. This introduces harmonics that detract from the mellow sound of the triangular waveform. The discrete amplifier has a larger slew rate and is largely free from this defect. C13 also helps to filter out the spike, but it does cause a slight falloff of the triangle

amplitude at high frequencies. The value of 1 n for C13 is by no means mandatory, and other values may be substituted to suit personal taste.

### Sine converter

As mentioned previously, the sine converter does not produce an extremely pure sinewave, but the circuit (figure 13) is simple and the output waveform is musically adequate. The triangle output from IC8 is fed to the non-inverting input of IC11 via P13 and R38. The positive and negative excursions of the triangle at the op-amp input are limited logarithmically by a matched pair of diodes D5 and D6, and the resulting approximation to a sinewave is amplified by IC11.

P13, R38 and R39 form an attenuator. The setting of P13 determines the triangle amplitude that would appear across R39 were D5 and D6 omitted, and hence the point on the triangle waveform at which limiting occurs. For example, with P13 set to maximum the voltage appearing across R39 will be very small, and D5 and D6 may conduct only on the peaks and troughs of the triangle, so the output will be too 'peaky'. On the other hand, with P13 set to minimum the signal will be

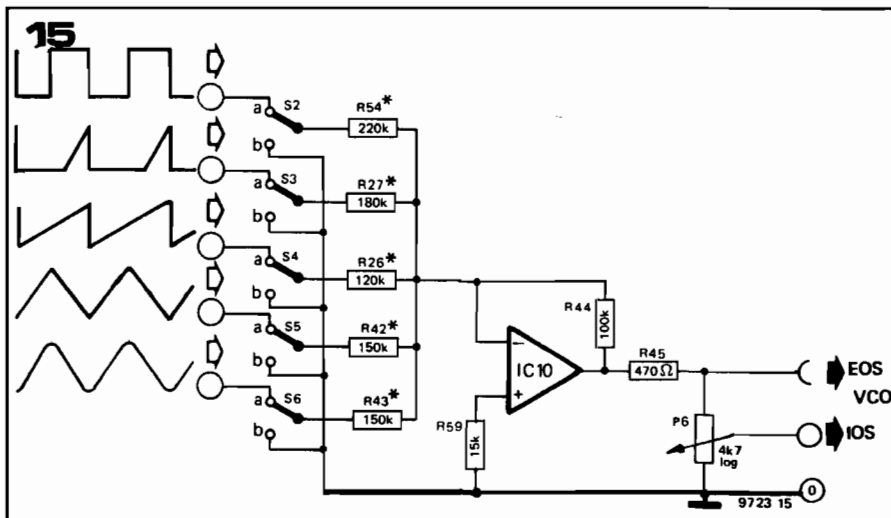

clipped very early in the waveform. Somewhere between these extremes is a setting of P13 that will give the best approximation to a sine wave. This setting can be found either by ear, or visually using an oscilloscope, or using a distortion meter to adjust for minimum distortion.

### Pulse width modulator

This section of the curve shaper generates a square wave whose duty-cycle can be preset to any desired value from 0 to 100%, or which can be modulated by an external signal. T6, T7 and T8 (figure 14) form a high speed voltage comparator whose output will go high when the sawtooth input voltage exceeds the base voltage of T7, and which will go low on the trailing edge of the sawtooth.

The base voltage of T7 is set by the output voltage of summing amplifier IC6, which can be fed both with a DC voltage via P5 and with a signal from the PWM input. As the output voltage of IC6 becomes more positive the comparator will trigger later and later along the sawtooth ramp, so the output pulse will be narrower. This is illustrated in figure 14b, which shows the response to a low-frequency triangular PWM input signal.

P14 and P15 set the range of P5, so that this control can be used to preset the duty-cycle over the range 0 to 100%. The amplitude of the PWM input, and hence the modulation depth, is controlled by P4. IC9, which is connected as a voltage follower, lights LED D8 whenever the comparator output is high. This indicates that the VCO is functioning, and the LED brightness also gives an indication of the duty-cycle of the square wave output.

### Output adder

The output adder circuit (figure 15) requires little explanation. When any switch is in the 'b' position then that input is open-circuit and the corresponding input resistor of the op-amp, IC10, is grounded. When a switch is in the 'a' position then the corresponding waveform is fed to the summing amplifier. Two or more waveforms may be summed by closing several switches simultaneously, which greatly extends the range of output waveforms available. The adder stage has two outputs: external output signal (EOS), which is routed to the socket on the VCO front panel, and internal output signal (IOS), which is internally wired to the voltage-controlled filter (VCF).

As a suggestion for those experimenters who wish further to increase the flexibility of the VCO system, switches S2 to S6 may be replaced by potentiometers to form a mixer circuit in which the amplitude of each input waveform fed to the summing amplifier is infinitely variable.

### Conclusion

The discussion of the VCO module has now reached the stage where the description of all the circuit sections is complete, and the musical value of the various output waveforms has been given some consideration. The following chapter will deal with the constructional aspects of the VCO, including selection of components, assembly of the module p.c. board, testing and adjustment. When this stage is reached the synthesiser will at last start to become a playable instrument insofar as the VCO will produce an output signal of the correct pitch when a key is depressed, although the full musical potential cannot be realised until the rest of the synthesiser is complete.

#### Literature:

Clayton, G.B.: "Experiments with operational amplifiers. 7. Using transistors for logarithmic conversion". *Wireless World*, Jan. 1973

"Nonlinear Circuits Handbook" Analog Devices, Norwood, Mass. (USA) 1974

Schaefer, R.A.: "New techniques for electronic organ tone generation". *JAES (Journal of the Audio Engineering Society)*, July/Aug. 1971

Hamm, R.O.: "Tubes versus transistors - is there an audible difference?". *JAES May 1973*

## chapter 5

# construction of the VCO

Having dealt with the theoretical circuits used in the VCO, this chapter goes on to discuss the selection of components and describes the practical construction, testing and adjustment of the VCO module.

Care must be taken in the choice of components for, and in the construction of, the VCO, if reliable performance is to be obtained. The same general comments apply that were made earlier with regard to component quality. In addition, the following points should be noted:

1. Capacitor C2 should be a low leakage type - preferably MKM or equivalent.
2. Transistor T1 to T3 should be tested,

as will be explained later.

3. Diodes D3 and D4 should be a matched pair.

It is important that the reset transistor T1 in the CCO section should be selected for low leakage current, as excessive leakage current means current lost from C2 and non-linearity of the CCO at low frequencies.

The test setup for T1 is shown in figure 1. The PNP transistor T8 can be used as the second transistor in the circuit, or any similar transistor can be used. The meter can be a multimeter set to the 1 mA range. The base of T8 is initially left open-circuit to check that it is not leaky. The meter should read zero. The base of T8 is then connected to the 0 V rail via a 100 k resistor to check that it has adequate current gain. The meter should read at least 1 mA (i.e. full-scale). The base of T8 is then connected to the collector of T1. Any leakage current through T1 will be amplified by the current gain of T8 to give a deflection on the meter. Only if the meter reads zero is the leakage current of T1 sufficiently low.

Finally, the current gain of T1 can be checked by connecting its base to +5 V through a 2k2 resistor, when the meter should again show full-scale deflection.

FETs T2 and T3 can be tested using the circuit given in chapter 3 for testing the FETs in the keyboard interface. Unlike the keyboard interface circuit, FETs which show a  $U_S$  in the test circuit of less than 0.5 V are not suitable for the VCO. However, FETs that have been rejected for the keyboard interface because their  $U_S$  value was too high, can be used in the VCO if the value of  $U_S$  lies between 1.6 V and 2 V. For FETs with  $U_S$  values between 0.5 and 1.5 V the source resistors R17 and R20 should be selected from table 1 in part 3. For FETs having a  $U_S$  value between 1.6 V and 2 V, R17 and R20 should be 4k7.

Diodes D3 and D4 should be purchased as a matched pair or, if several diodes of the correct type are to hand, a reasonably matched pair may be selected by measuring the forward voltage drop versus forward current characteristics of the diodes and selecting the pair that are most similar.

### Construction

Once these critical components have been selected, construction of the VCO may commence. On the printed circuit board the VCO is split into two functional sections: the exponential converter and CCO, the complete circuit of which is given in figure 2a, and the curve shaper section, the complete circuit of which is given in figure 2b. These two circuits are the combination of all the partial circuits discussed in the previous chapter.

Printed circuit board and component layouts for the VCO are given in figure 4. The oscillator section occupies the top third of the board, whilst the remainder of the board contains the



Figure 1. Simple test circuit for selecting transistor T1 of the VCO.

Figures 2a and 2b. These two circuits constitute the complete VCO, and combine into two functional groups the partial circuits discussed the previous chapter.

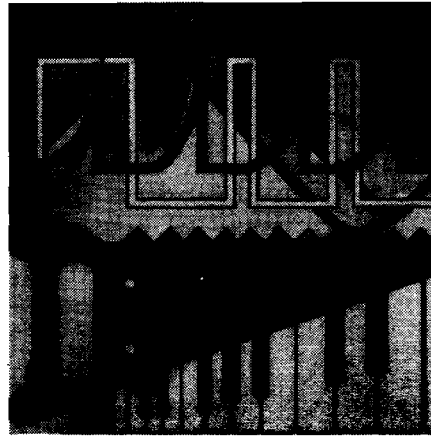

curve shaper circuits. To avoid interaction between the two sections of the circuit they each have separate supply and ground connections. The only link between them is at the source of T3, which is the CCO output (point A in figures 2a and 2b). Assembly of the board poses no particular problems, the only point to note being that at this stage C13, R26, R27, R42, R43, R54, and the link joining pin 4 of IC3 to the gate of T2, are omitted for test purposes.

**Test and adjustment**

The first test is to check that the CCO is functioning, and for this purpose a 1 M resistor is connected between the gate of T2 and -15 V to act as a current

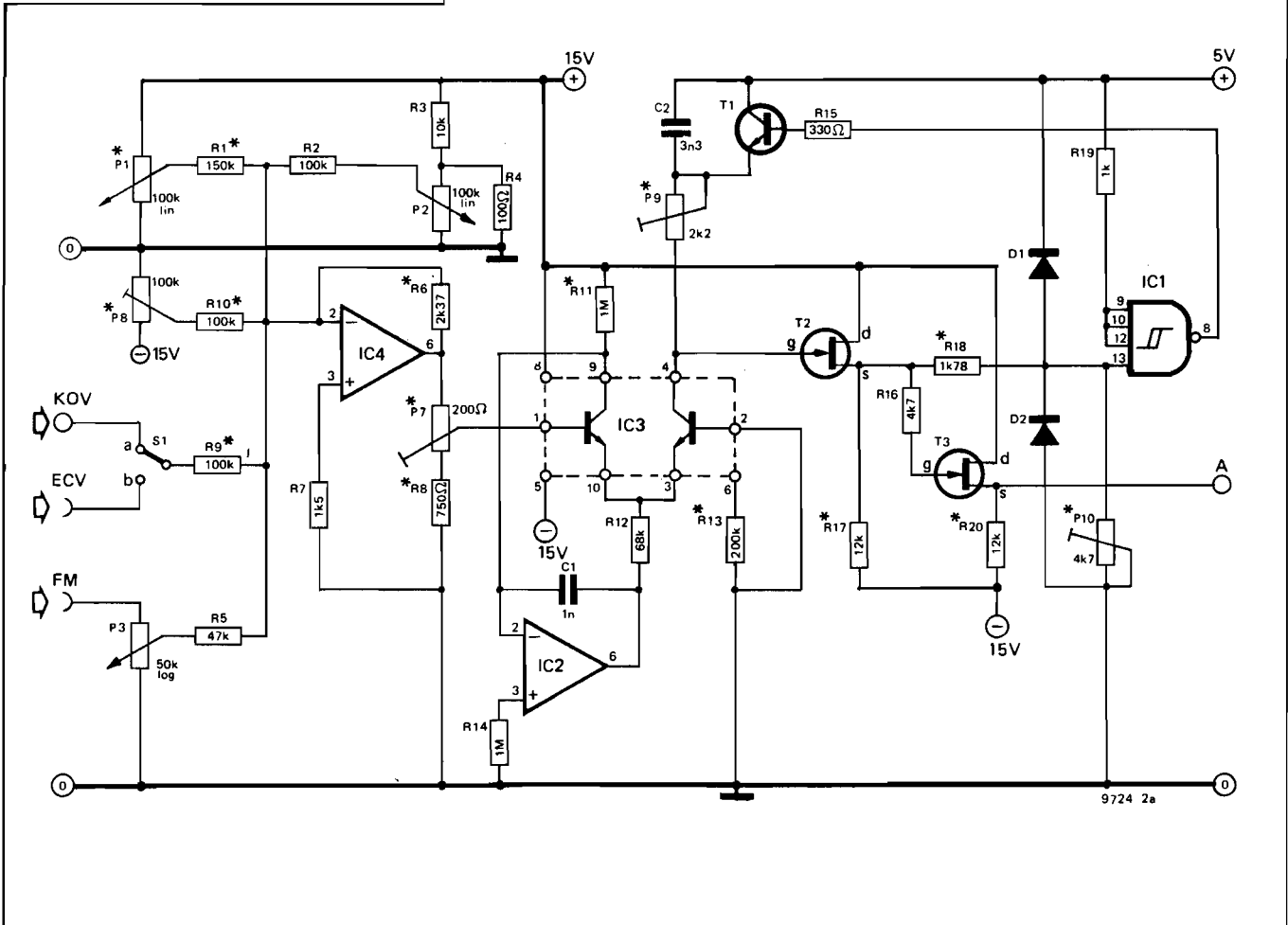
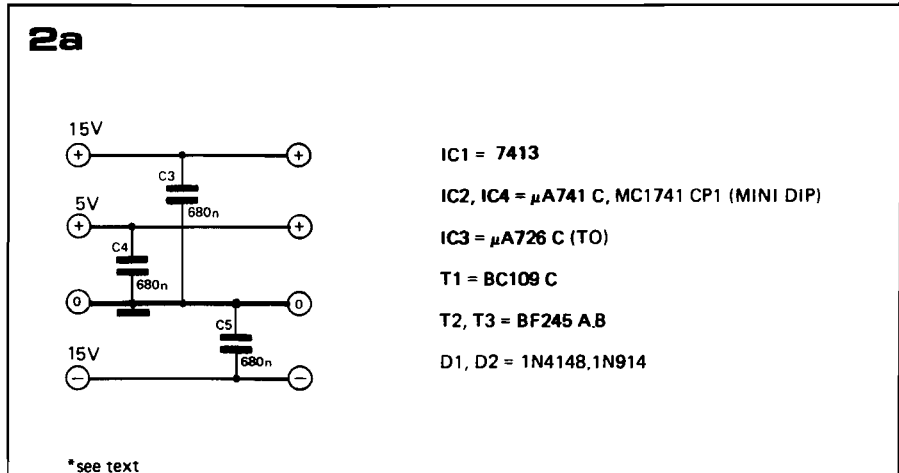
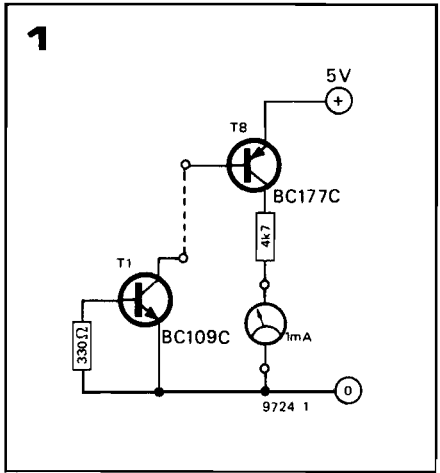

source for the CCO. The CCO output can be monitored with an oscilloscope at point A.

Should the oscillator fail to start then P10 can be adjusted until it does. It will probably be found that the oscillator stops as the slider of P10 approaches its two extreme positions, and P10 should be set midway between the positions at which oscillation ceases. At this stage, the frequency of the oscillator should be around 1 kHz, and the waveform will not be a perfect sawtooth, but will exhibit an exponential curvature due to the 1 M resistor being used in place of a constant current source.

Once the CCO has been checked, the 1 M resistor can be removed and the CCO connected to the exponential

converter by soldering in the link between pin 4 of IC3 and the gate of T2.

With the sliders of P2, P3 and P8 turned to zero volts and the KOV input grounded, it should now be possible to vary the VCO frequency by adjusting P1. If the exponential converter is operating correctly, the waveform at point A should be a perfect sawtooth. It may be found that at low frequencies the VCO will not oscillate reliably, in which case the adjustment of P10 will require further attention.

Once the VCO functions reliably over the entire audible range, P1 should be turned completely anticlockwise and the offset potentiometer P8 adjusted until the lower frequency limit (with no

control voltage other than from P8) is around 15 Hz. This adjustment does not need to be extremely accurate. If desired, the frequency range of the VCOs can be extended beyond the existing 10 kHz. There are two possibilities: either R12 can be reduced to 47 k, or else C2 can be reduced to 2n7 (or even 2n2).

### Curve shaper section

Adjustment of the curve shaper begins with the spaced sawtooth converter section. P11 adjusts the clamp level of this circuit and hence the 'spikeness' of the waveform, which affects the tonal quality. The adjustment is a matter of taste, but as a guideline the peak-to-

2b

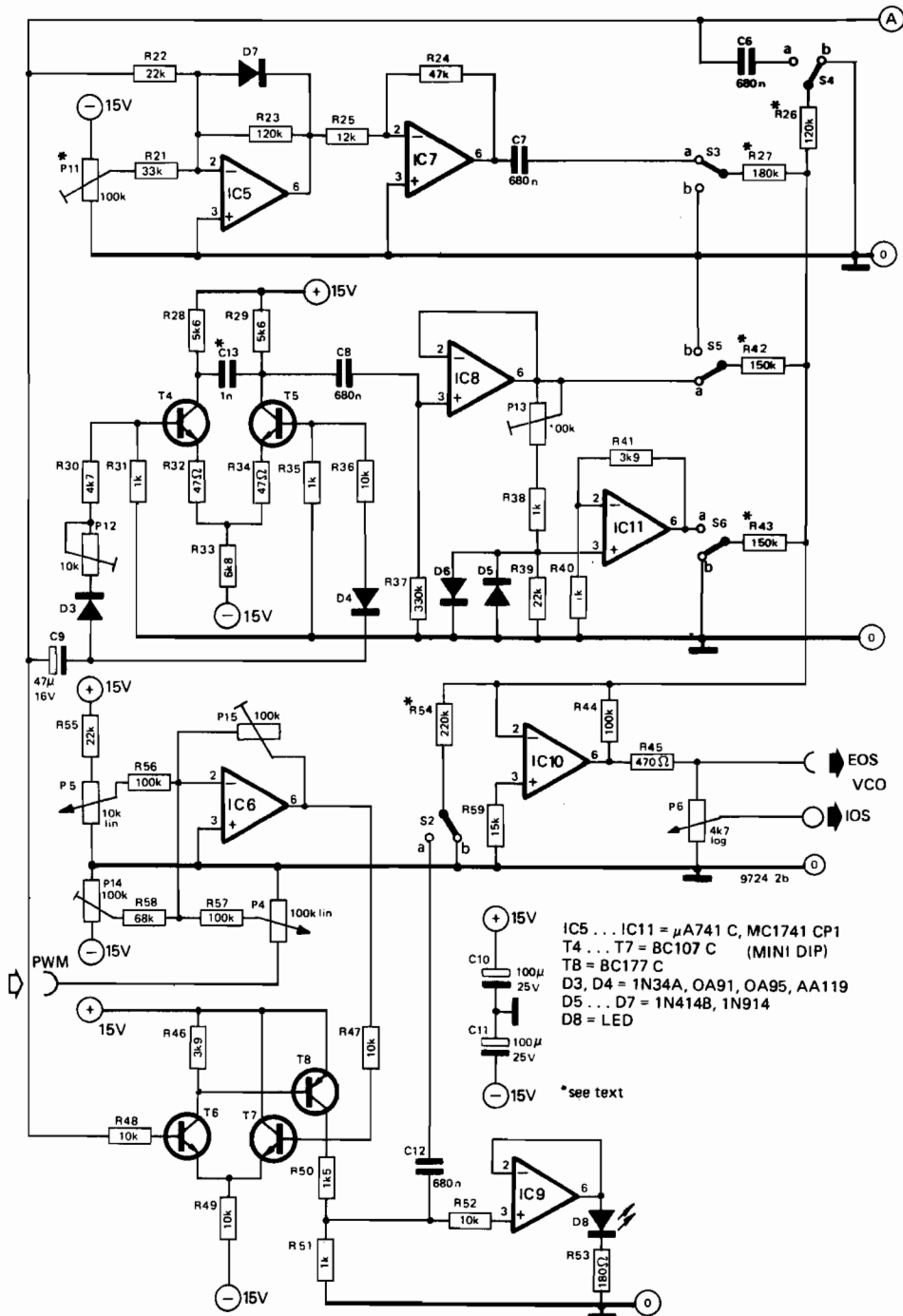

peak amplitude of the waveform, viewed at point S3a, should be about 3 V.

Next, the triangle converter (T4, T5) can be adjusted. The symmetry of the triangle waveform is determined by the matching of diodes D3 and D4. P12 can compensate for slight mismatches in these diodes, but if the degree of mismatch is large the only answer is a better matched pair of diodes. The output waveform should be monitored at point S5a with P12 in its mid-position, and P12 should then be turned one way or the other to obtain a symmetrical triangular waveform. If notches are apparent at the peaks of the triangle waveform (especially noticeable at high frequencies) then capacitor C13 should be added. The value of 1 n is given as a guideline, but C13 should preferably be chosen experimentally to give the best compromise between elimination of the notches and attenuation of the signal at high frequencies.

Once the triangle waveform is satisfactory the sine converter may be adjusted. Ideally, diodes D5 and D6 should also be a matched pair in order to ensure symmetry of the sine waveform. However, a random pair of 1N4148s or 1N914s will usually prove to be a sufficiently close match in practice. The purity of the sinewave is adjusted visually by monitoring the waveform at point S6a and varying the resistance of P13 for best results. The sine converter output can be compared with the sine output of a signal generator, if available, or with a sine curve plotted on graph paper. The purists may like to adjust for minimum distortion using a distortion meter, though the simpler adjustment procedure is adequate from a musical point of view.

The final section of the circuit to be adjusted is the pulse-width modulated squarewave generator. The aim of this adjustment is to set trimmers P14 and P15 so that the adjustment range of P5 varies the duty-cycle from 1% to 99%. The setting-up procedure is as follows:

- 1) Adjust P14 until its wiper voltage is -5.5 V, and adjust P15 to maximum resistance.
- 2) Connect the voltmeter to the output of IC6 and monitor the PWM signal at point S2a with an oscilloscope.
- 3) Adjust P5 to give first maximum (approx. 99%) and then minimum pulse width (approx. 1%) of the PWM signal, and note the output voltage of IC6 for these two conditions thus: -  $V_{max}$  = voltage for minimum pulse width,  $V_{min}$  = voltage for maximum pulse width.

3

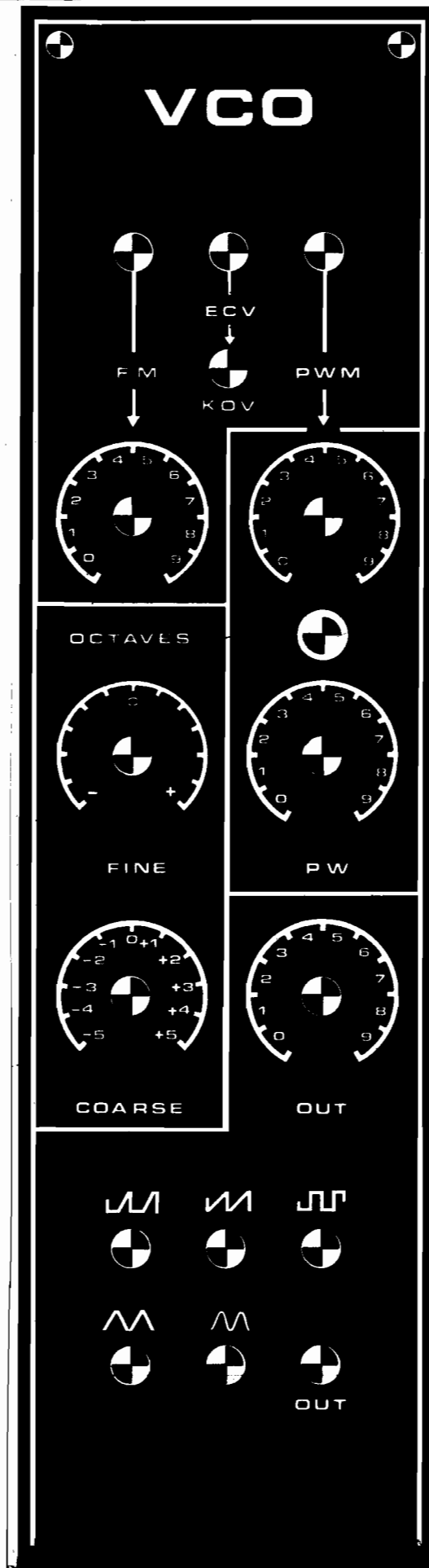
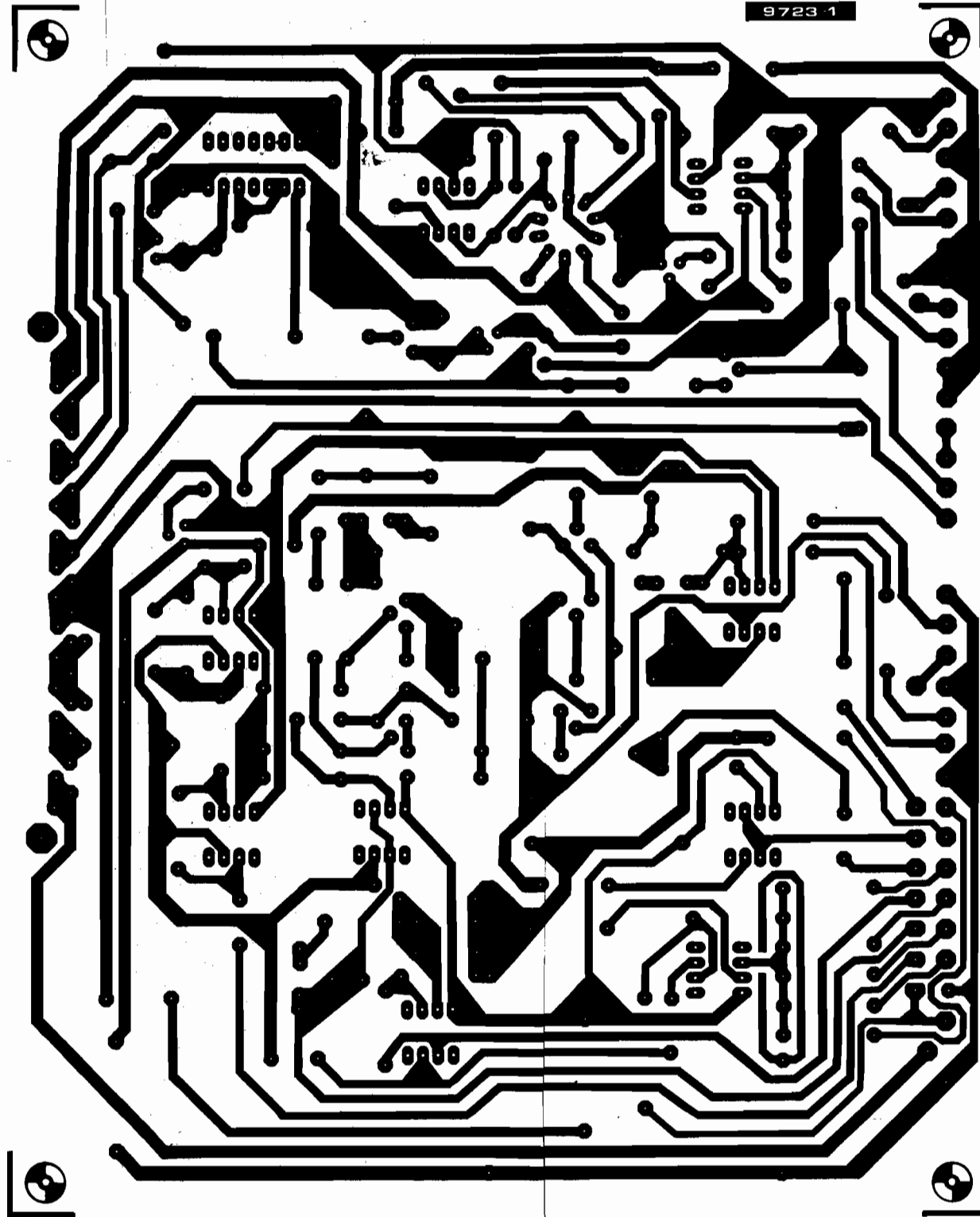

Figure 3. Suggested front panel layout for the VCO.

4

9723-1



**Parts list for figures 2 and 4.**

**Resistors:**

a. 1% metal oxide

R1 = 150 k  
 R6 = 2k37<sup>1</sup>  
 R8 = 750  $\Omega$   
 R9, R10 = 100 k  
 R11 = 1 M  
 R13 = 200 k  
 R18 = 1k78<sup>1</sup>

<sup>1</sup> These are 'optimum' values. However, 2k4 and 1k8 resistors can be used

for R6 and R18 respectively, provided they are 1% metal oxide types!!

b. 5% carbon film

R2, R44, R56, R57 = 100 k  
 R3, R36, R47, R48, R49, R52 = 10 k  
 R4 = 100  $\Omega$   
 R5, R24 = 47 k  
 R7, R50 = 1k5  
 R12, R58 = 68 k  
 R14 = 1 M  
 R15 = 330  $\Omega$   
 R16, R30 = 4k7  
 R17, R20 = 12 k (nominal)

R19, R31, R35, R38, R40, R51 = 1 k  
 R21 = 33 k  
 R22, R39, R55 = 22 k  
 R23 = 120 k  
 R25 = 12 k  
 R26 = 120 k (nominal)  
 R27 = 180 k (nominal)  
 R28, R29 = 5k6  
 R32, R34 = 47  $\Omega$   
 R33 = 6k8  
 R37 = 330 k  
 R41, R46 = 3k9  
 R42, R43 = 150 k (nominal)  
 R45 = 470  $\Omega$

R53 = 180  $\Omega$   
 R54 = 220 k (nominal)  
 R59 = 15 k

**Presets:**

a. Cermet  
 P7 = 200  $\Omega$  (or 220  $\Omega$  or 250  $\Omega$ ) multiturn preset.

Note pinout, end pins spaced 5.1 mm and 7.6 mm from centre pin, which is offset by 2.5 mm.

P8, P11 = 100 k  
 P9 = 2k2  
 P10 = 4k7

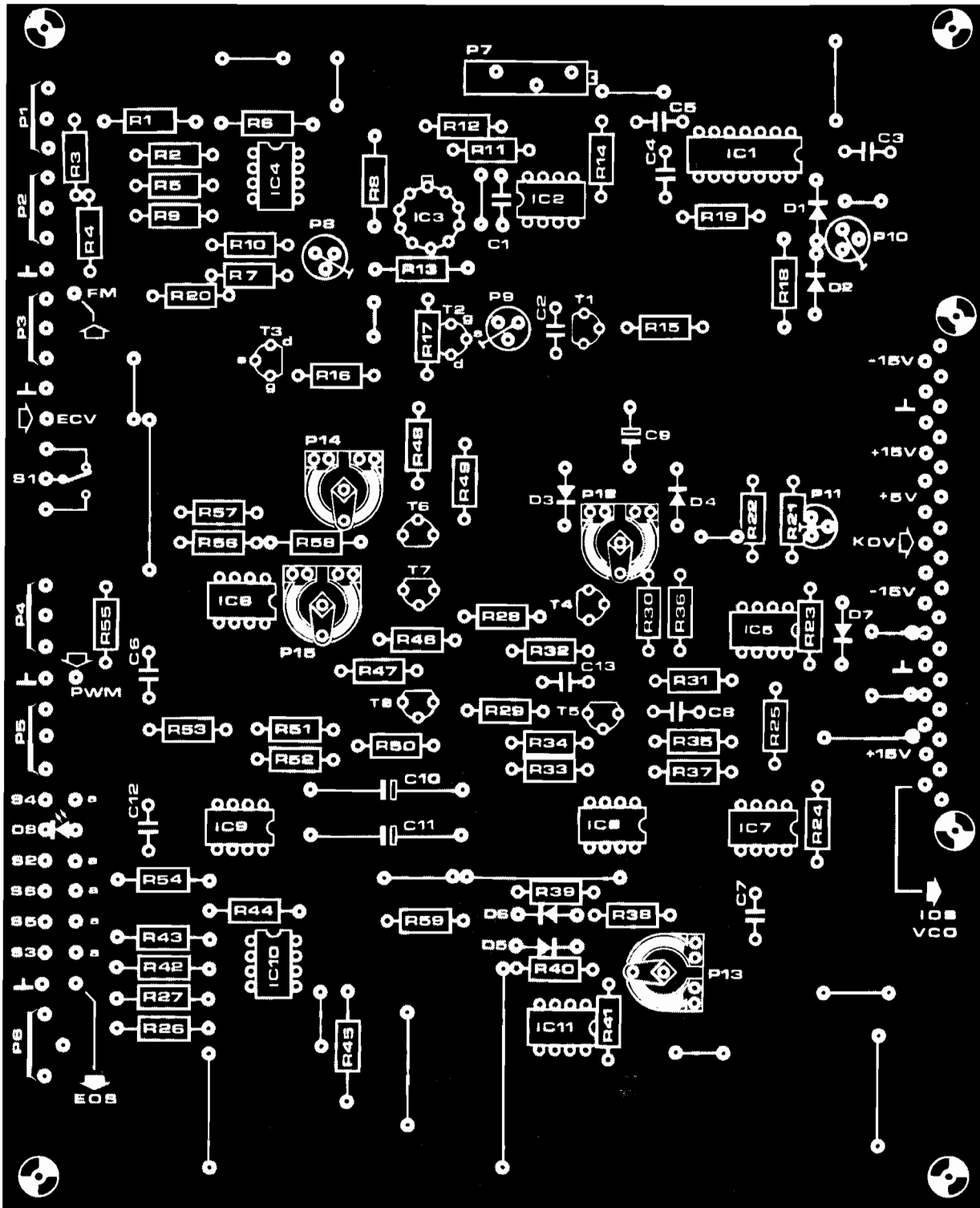

b. Carbon  
 P12 = 10 k  
 P13, P14, P15 = 100 k

**Potentiometers:**

a. Cermet  
 P1 = 100 k lin

b. Carbon  
 P2, P4 = 100 k lin  
 P3 = 50 k log.  
 P5 = 10 k lin.  
 P6 = 4k7 (5 k) log.

**Capacitors:**  
 C1 = 1 n

C2 = 3n3 (MKM)  
 C3, C4, C5, C6, C7,  
 C8, C12 = 680 n  
 C9 = 47  $\mu$ /16 V  
 C10/C11 = 100  $\mu$ /25 V  
 C13 = 1 n (see text)

**Semiconductors:**

T1 = BC109C  
 T2, T3 = BF 245A, B  
 T4 ... T7 = BC107C  
 T8 = BC177C  
 D3, D4 = OA91, OA95,  
 AA118, AA119, or 1N34A

D1, D2, D5,  
 D6, D7 = 1N4148, or  
 1N914  
 D8 = LED, TIL209 or  
 similar  
 IC1 = 7413  
 IC2, IC4, IC5, IC6, IC7, IC8,  
 IC9, IC10, IC11 =  $\mu$ A 741C  
 or MC 1741 CP1  
 (MINI DIP)  
 IC3 =  $\mu$ A 726C (Fairchild,  
 TO package)

**Miscellaneous:**  
 31 pin (DIN 41617)  
 connector  
 S1 ... S6 = SPDT  
 miniature toggle switch.  
 4 x 3.5 mm jack sockets

**Figure 4.** Printed circuit board and component layout for the Formant VCO (EPS 9723-1).

- 4) Turn the wiper of P14 to zero volts and the wiper of P5 to maximum voltage. Now use P15 to adjust the output voltage of IC6 so that it is equal to the difference between the two previously noted values  $V_{max}$  and  $V_{min}$  i.e.

$$V_{o,IC6} = V_{min} - V_{max}$$

The output voltage of IC6 will be negative since it is connected as an inverting amplifier.

- 5) Adjust P14 to give maximum pulse-width (99% duty-cycle) of the output signal. When the wiper of P5 is now turned to zero volts the pulse width should be minimum (1% duty-cycle). This completes the adjustment of the PWM stage.

Oscillograms of all the waveforms are shown in photos 1 to 7.

### Output adder

Once the various sections of the curve shaper have been adjusted the input resistors of the output adder may be selected (R26, R27, R42, R43 and R54). A 250 k potentiometer is connected in place of each resistor in turn, and the peak-to-peak amplitude of the relevant waveform is adjusted to about 2.5 V at output EOS. The resistance of the pot is then measured and it is replaced by a fixed resistor of the nearest preferred value from the E24 range.

### Front panel

A front panel layout for the VCO is given in figure 3. The three inputs, FM, ECV and PWM are at the top of the panel, with the switch (S1) to select between ECV and KOV mounted below. Potentiometer P3, which controls the FM modulation depth, is mounted below the FM input socket, while P4 and P5, which control the pulse width modulation depth and duty-cycle respectively, are mounted below the PWM input socket. The coarse and fine tuning controls (P1 and P2) are also grouped together, on the left of the panel, while the output level control (P6) is grouped with the waveform selection switches (S2 to S6) and the output socket.

### Module construction

It is essential that the VCO module should be screened to avoid any interference pickup. To provide this screening, and to make the module mechanically rigid, the p.c. board is mounted on a carrier made from 16 or 18 SWG aluminium. The dimensions of the carrier are those of a large Eurocard (165 mm x 210 mm) so that the module will fit a Euro-standard card frame. A right-angle bend at the front edge of the carrier allows it to be secured to the front panel by means of the potentiometer mounting bushes. The p.c. board is mounted on the carrier using M3 screws and spacers. Photo 8 shows the completed module.

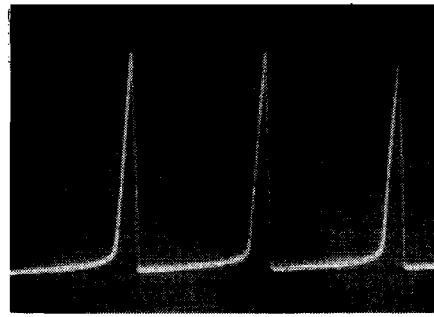
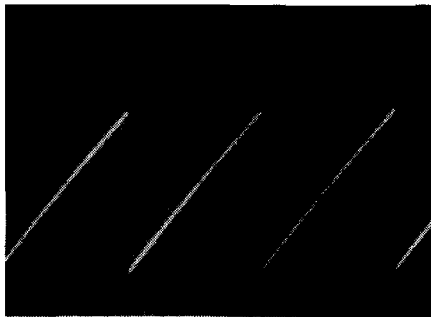

ECV	= External Control Voltage, i.e. front-panel input to VCO.
KOV	= Keyboard Output Voltage, i.e. permanently wired input to VCO from interface receiver.
FM	= Frequency Modulation input
PWM	= Pulse Width Modulation input
EOS	= External Output Signal from VCO (front panel output)
VCO/IOS	= Internal Output Signal from VCO, will be permanently wired to one VCF input.

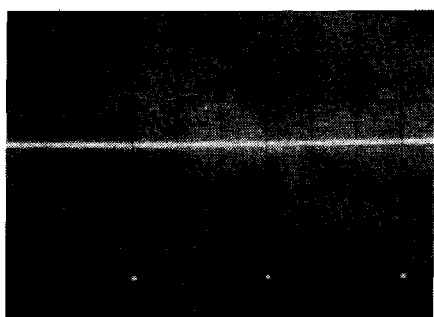
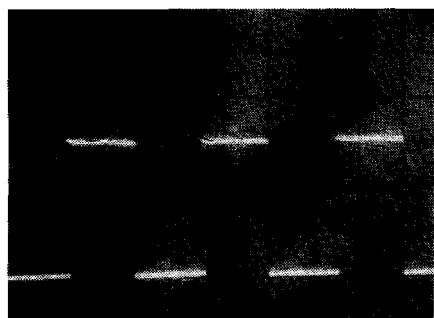
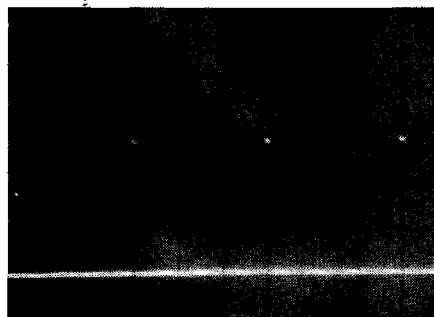
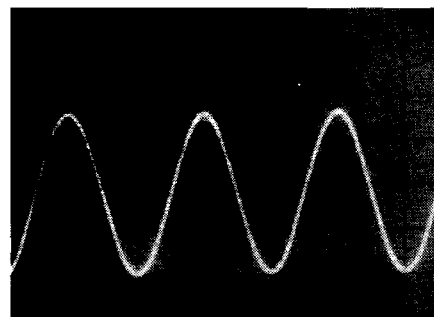
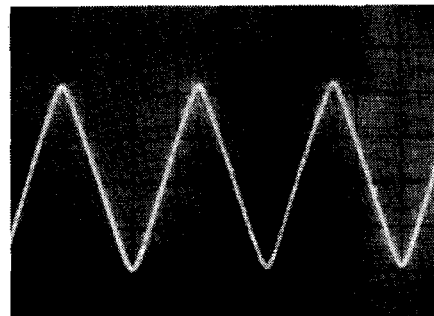

Photos 1 to 7. These oscillograms give an indication of the waveforms that should be available at the curve shaper outputs:

1. Sawtooth
2. Spaced sawtooth
3. Triangle
4. Sinewave
5. Squarewave, minimum duty-cycle
6. Squarewave, 50% duty-cycle
7. Squarewave, maximum duty-cycle.

Photo 8. The completed VCO module.

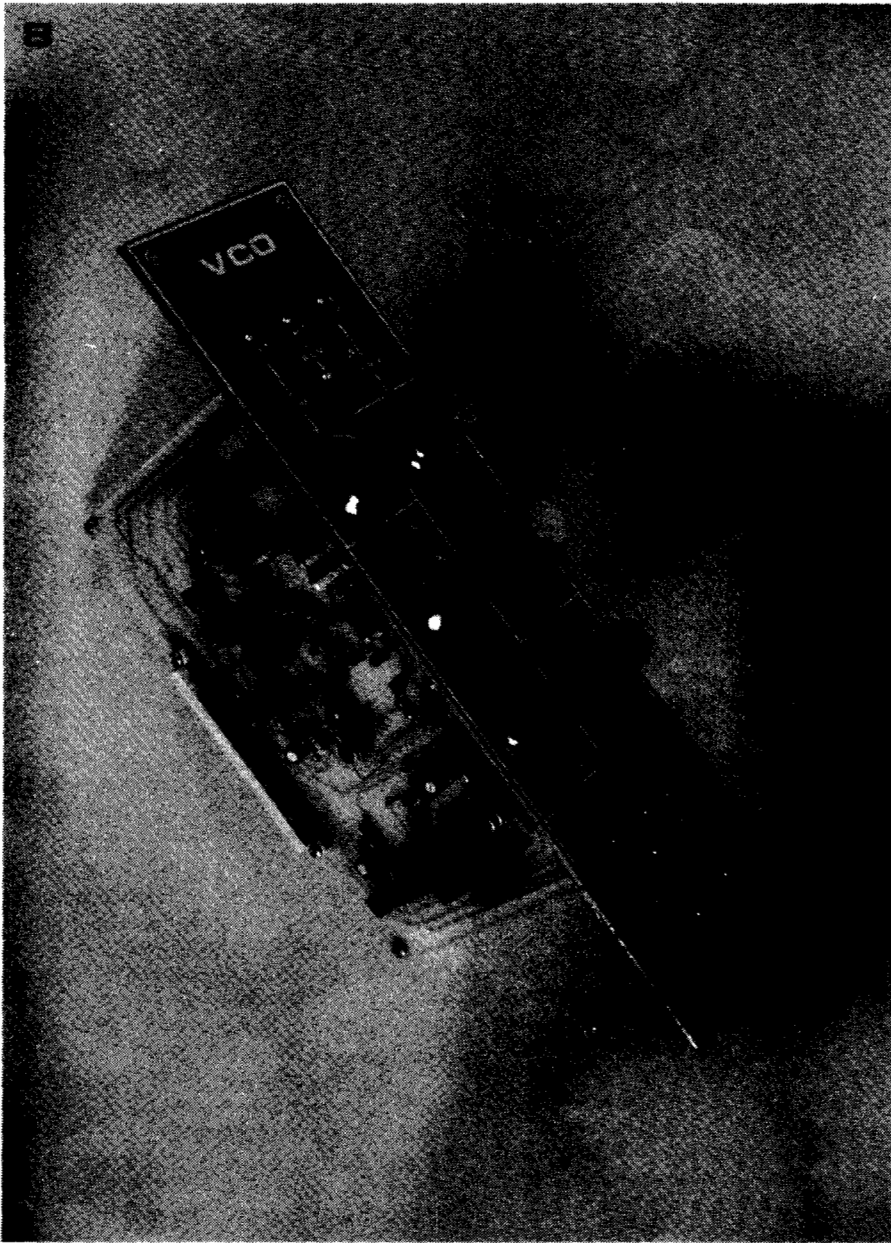

### Octaves/Volt adjustment

The most critical adjustment made to the entire synthesiser is the setting up of the octaves/volt characteristic of the VCOs, as this adjustment determines the accuracy of the synthesiser tuning.

There are two methods of adjusting the VCO. The simpler method requires the use of a frequency counter and digital voltmeter, while the second method requires an audio signal generator with a calibrated frequency scale.

Before commencing the adjustment procedure power should be applied to the VCO for several minutes to allow the temperature (especially of IC3) to stabilise.

To adjust the VCO using frequency counter and DVM, all inputs and controls of the VCO input adder are set to zero volts and P9 is set in its centre position. The connection between the wiper of P1 and R1 must be unsoldered, and the free end of R1 connected to ground, whilst the wiper of P1 is connected to the KOV input with S1 in position 'a'. The frequency counter is

connected to the VCO output and the DVM to the wiper of P1. With P1 turned fully anticlockwise the frequency counter will read around 15 Hz, which was set previously by means of P8. P1 is now turned slowly clockwise until the DVM reads 1 V, when the VCO frequency should be twice what it was with P1 set to zero, e.g. if the zero frequency was exactly 15 Hz the frequency should now be exactly 30 Hz. Of course, initially this will not be the case, and some adjustment of P7 will be required. P1 is then turned until its wiper voltage is exactly 2 V, when the VCO frequency should be four times the zero voltage frequency, e.g. 60 Hz. This procedure is repeated at 1 V steps over the entire range of P1, checking that the correct frequency is obtained at each step. Thus if 0 V = 15 Hz, then 1 V = 30 Hz, 2 V = 60 Hz, 3 V = 120 Hz etc. P7 is adjusted to obtain the best accuracy possible over the widest frequency range. At high frequencies (greater than 3 kHz) P9 can be used to correct any deviations from the 1 octave/volt characteristic.

To adjust the VCO using the beat note

method, the outputs of an audio oscillator and the VCO must be fed into the left- and right-channels of a stereo amplifier, or via an audio mixer into a mono amplifier, so that the beat notes can be heard via the loudspeakers. The VCO is connected to the KOV output of the previously calibrated keyboard.

The audio oscillator is set to a frequency between 400 and 500 Hz, and the main tuning of the keyboard is switched off. The top note of the keyboard is then depressed, and the VCO tuning controls P1 and P2 are adjusted until the audio oscillator and VCO are in tune with zero beat.

Next, the key an octave lower is depressed, when a dissonance or very rapid beat note will be heard. P7 is then adjusted until zero beat is obtained between the audio oscillator and the VCO note one octave lower.

The top key is again depressed, when it will be found that, due to the adjustment of P7, a beat note is again heard. Using the VCO tuning controls, readjust for zero beat, then depress the key an octave lower, which will now be slightly out of tune due to adjusting the VCO tuning controls. P7 must therefore be readjusted to obtain a zero beat.

This procedure is repeated several times until the oscillator is perfectly in tune with both the top note and the note an octave lower. The tuning is then checked two octaves and three octaves below top C, and if necessary P7 is readjusted to obtain the best tuning over the entire keyboard range.

The higher ranges of the VCO must now be adjusted using P9. For this purpose the audio oscillator is tuned to around 2 kHz, the bottom note of the keyboard is depressed, and the coarse and fine tuning controls of the VCO are adjusted for zero beat. The key an octave higher is then depressed, and P9 is adjusted for zero beat using the same technique as for the previous adjustment procedure using P7. The tuning is then checked two octaves and three octaves above bottom C.

This completes the adjustment of the VCO.



## chapter 6

**12 dB VCF**

This chapter introduces the first of the tone-shaping modules which process the 'raw' output of the VCOs to provide a wide variety of different tone colours and amplitude dynamics. The module presented here is a 12 dB per octave voltage-controlled filter (VCF) which is used to tailor the frequency spectrum of the VCO signal.

Before looking at the VCF circuit in detail, it is worth examining the ways in which the VCF is used. Four filter functions are available. A lowpass filter with a rolloff of  $-12$  dB per octave above the turnover point, a highpass filter with a rolloff of  $-12$  dB per octave below the turnover point, a bandpass filter with variable Q and minimum slope of  $-60$  dB per octave on either side of the centre frequency, and a notch filter. The turnover point – or centre frequency in the case of the band filters – is the same for all four filter functions, and can be varied by the application of a control voltage.

**Lowpass filter**

The simplest use of the VCF is what might be called static tailoring of a VCO output using the KOV output of the keyboard to control the VCF. Suppose (to give a simple example), it is required to filter out a large proportion of the harmonics of the squarewave signal to produce a flutelike tone. The lowpass function of the VCF would be used and the turnover point would be set so that when a particular key was depressed the desired tone colour was obtained. If a higher note is depressed then the VCO pitch will increase. However, since the KQV output is also applied to the VCF the turnover point of the VCF will increase with the VCO frequency, so that it always remains in the same octave relationship to the VCO frequency. The same harmonic structure of the output waveform is thus maintained, – i.e. the VCF is being used as a tracking filter.

If the VCF is used simply as a tracking filter then the harmonic content of the output remains fixed for the duration of each note. However, dynamic variation of harmonic content during a note is also possible by controlling the VCF from the envelope shaper.

For example, to provide a good imitation of a trombone sound the note should initially start off with only a weak harmonic content. As the loudness of the note builds up the harmonic

content also increases, i.e. the note becomes 'brighter'. Similarly, at the end of the note it is the harmonics which die away first.

This is achieved by using the VCF in the lowpass mode as a tracking filter with ADSR control, i.e. with inputs from KOV and from the envelope shaper. When a key is depressed the turnover point is initially determined by the KOV input, and is set so that the harmonics are filtered out. As the envelope shaper output voltage rises (attack) the turnover frequency of the VCF is increased to pass more of the harmonic content. At the end of the note (decay) the envelope shaper output falls and the turnover frequency of the VCF is reduced to filter out the harmonics once more.

These two simple examples relate to the imitative capability of the synthesiser, since most people will have a 'feel' for the sound of conventional musical instruments. However, it must once again be stressed that the synthesiser is not limited merely to an imitative role. It can also produce sounds that are unique to itself, that do not occur naturally and are totally 'electronic'.

**Highpass filter**

So far only the use of the lowpass filter has been discussed. The highpass filter has the opposite effect to the lowpass filter, i.e. it can be used to attenuate the fundamentals of notes while retaining the harmonics. This is obviously useful for sounds which have only a weakly developed fundamental or a bright tonal character, such as harpsichord and spinet type sounds, and certain string and brass instruments. When controlled by the envelope shaper the highpass filter can also give an 'ethereal' character to a sound.

**Bandpass filter**

In addition to the fundamental and harmonic series produced when a particular note of the instrument is sounded, brass and many woodwind instruments exhibit a number of fixed bandpass resonances, which are determined by the particular mechanical construction of the instrument. Use of the VCF as a bandpass filter with fixed centre frequency (KOV input switched off), together with a second VCF as lowpass tracking filter, allows these instruments to be more accurately imitated.

**Pedal controlled Wa-Wa**

Using the VCF in the bandpass mode with a fairly high Q-factor, A Wa-Wa effect can be obtained by controlling the VCF with a 0 to 5 V DC supply from a pedal-controlled potentiometer (such Wa-Wa pedals are available commercially or are easily home-made).

**Notch filter**

By sweeping the centre frequency of the

notch filter up and down the spectrum, either manually using a potentiometer or automatically using a low-frequency oscillator, phaser-type sounds can be produced. If this is done using a white noise input instead of a VCO then interesting 'jet-aircraft' noises can be obtained.

**Design of the VCF**

As far back as 1965, R.A. Moog designed 24 dB/octave lowpass and highpass filters, and no satisfactory alternative to these was found for several years, although they were periodically 're-invented' by others. It was not until the introduction of a specific type of integrated circuit, the operational transconductance amplifier (OTA), that a viable alternative became possible.

The Formant VCF is developed from the two-integrator loop shown in figure 1. Although a complete mathematical analysis of this circuit is beyond the scope of this book (those interested are referred to the bibliography), the basic concept is fairly simple to grasp.

The two-integrator loop can be considered as an analogue computer for the solution of a second-order differential equation. If the input resistor R1 and potentiometer PQ are removed, it can be seen that the circuit bears a remarkable resemblance to a quadrature oscillator. In fact, if the loop gain of the circuit is sufficient then it will function as an oscillator – at the frequency for which the differential equation solution holds.

PQ provides damping so that the circuit does not oscillate, but merely acts as a filter. Highpass, bandpass, and lowpass filter functions are available simultaneously at outputs (1), (2) and (3) respectively. At the turnover or centre frequency of the filters there is  $90^\circ$  phase shift between the integrator inputs and outputs. Thus between point (1) and point (3) there is  $180^\circ$  phase shift in all. By combining outputs (1) and (3) using a voltage follower A4 a notch function can be obtained. Since the two inputs are  $180^\circ$  out of phase at the centre frequency there is a null at the junction of the voltage follower's two input resistors at this frequency.

Of course the centre/turnover of this filter is not voltage-controlled, but is fixed by the integrator constants R and C, so to achieve voltage control one of these elements must itself be voltage-controlled. Voltage control of capacitance is impractical in this application. Voltage controlled resistors are possible in the form of LED/LDR combinations or FETs, but unfortunately both these methods suffer from disadvantages such as unpredictable performance due to wide tolerances, small control range, poor linearity, and breakthrough of the control signal.

An alternative solution can be found by re-thinking the basic integrator design. The classic op-amp integrator consists

Figure 1. The two-integrator loop used in the Formant VCF provides 12dB/octave highpass, bandpass and with the addition of A4, a notch filter.

Figure 2. Instead of normal op-amps, OTAs are used in the Formant VCF. The output current change is  $g_m$  times the input voltage change, but  $g_m$  can be varied by feeding in a control current  $I_{ABC}$ .

Figure 3. The OTA integrator used in the Formant VCF. The integrator time constant is controlled by the current  $I_{ABC}$ . A high impedance buffer ensures that all the output current of the OTA flows into the integrator capacitor.

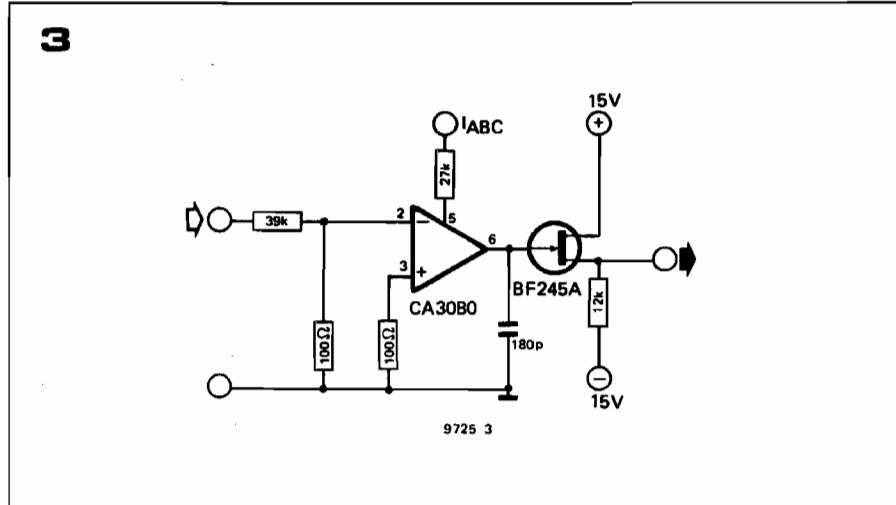
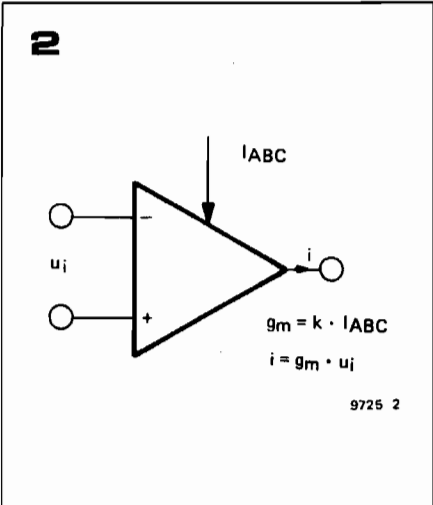
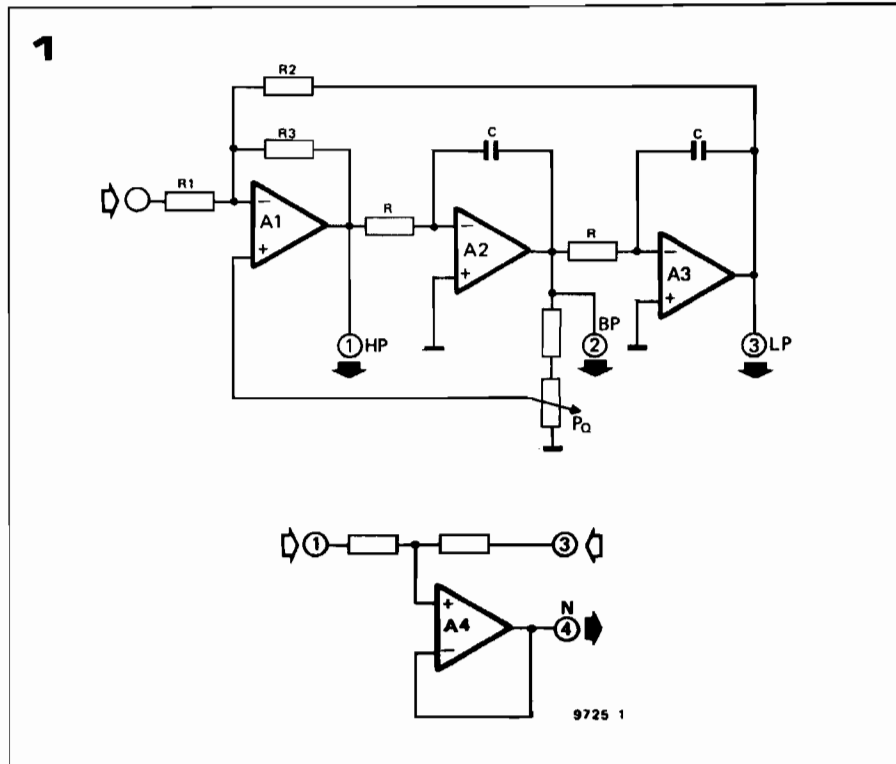

of a differential-input voltage amplifier with the non-inverting input grounded. An input resistor connected to the inverting input (which is a virtual earth point) converts the input voltage into a proportional current. Since this current cannot flow into the inverting input it must flow into the feedback capacitor, and a voltage appears across the capacitor (and hence at the op-amp output).

It is fairly obvious that the op-amp is functioning simply as a voltage-to-current converter, and an equivalent circuit for an integrator would be an amplifier with a voltage-controlled current output, with a capacitor connected, not in a feedback loop, but between the output and ground. Varying the voltage-current transconductance of the amplifier would then effectively vary the 'resistance' constant of the integrator.

A suitable device exists ready-made in the shape of the operational transconductance amplifier or OTA. This is

**Hardwired inputs:**

- KOV = Keyboard Output Voltage (from interface receiver).
- ENV = Envelope shaper control voltage (from ADSR unit).
- VCO 1, 2, 3 = From VCOs 1, 2 and 3.

**Front-panel inputs:**

- ECV = External Control Voltage.
- TM = Tone colour ('Timbre') Modulation input.
- ES = External Signal, e.g. noise, input.

**Outputs:**

- VCF/IOS = Internal Output Signal from VCF, (will be hardwired to a VCA).
- EOS = External Output Signal from VCF (front panel output).

**Front-panel controls:**

- OCTAVES = P1, coarse frequency adjustment.
- ENV = P2, sets envelope shaper control voltage.
- TM = P3, sets tone colour modulation level.
- ES = P4, sets external signal level.
- Q = P5, Q-factor adjustment.
- OUT = P6, sets VCF/IOS output level (not EOS!).
- ECV/KOV = S1, selects external or internal control voltage input.
- HP = S2, selects high-pass output.
- BP = S3, selects bandpass output.
- LP = S4, selects low-pass output.
- N = S2 + S4, selects notch (band-stop) output.

4

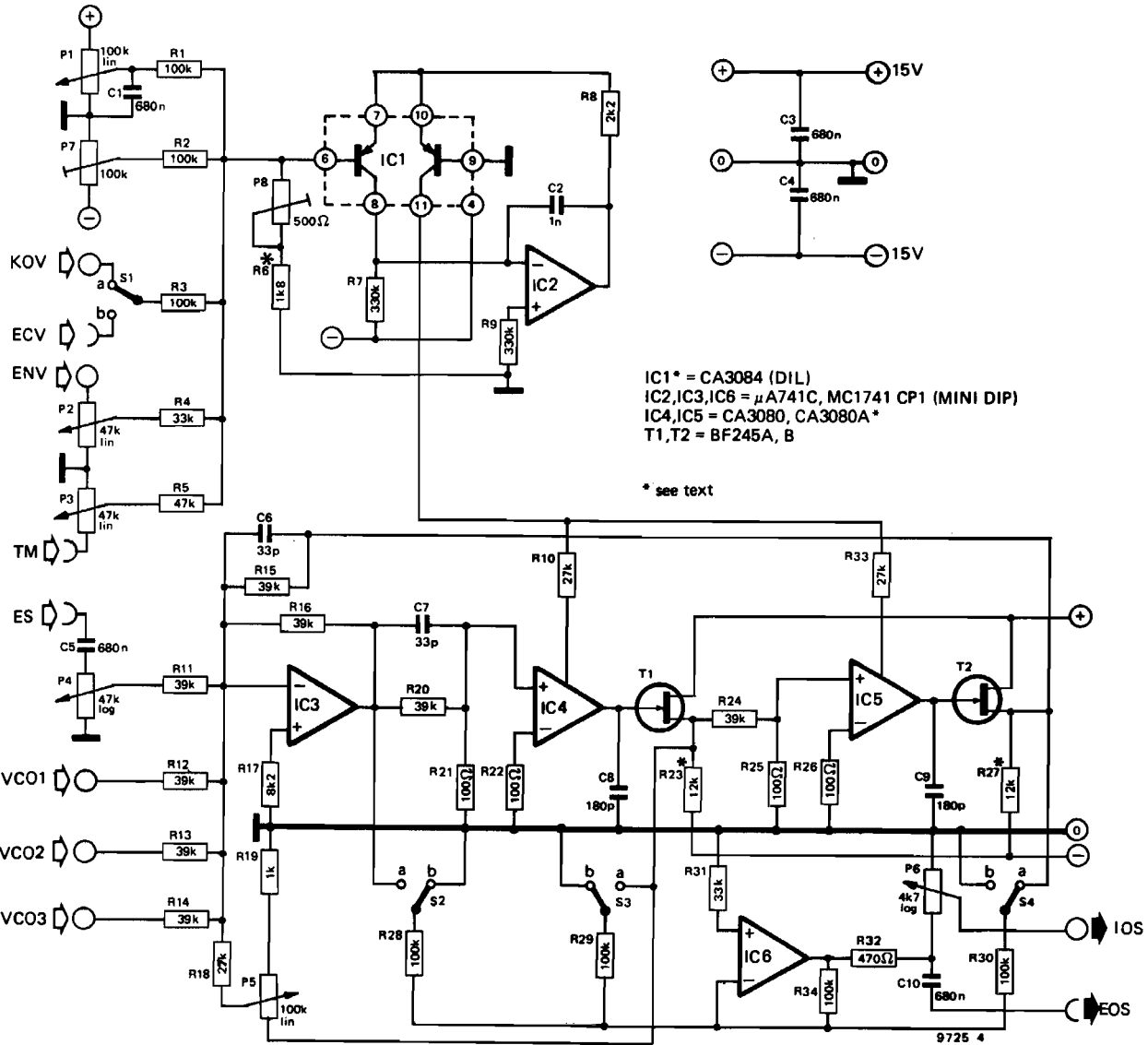

an amplifier that produces an output current which is proportional to the input voltage, i.e.  $i = g_m \cdot u_i$ , where  $i$  is the output current,  $u_i$  is the input voltage and  $g_m$  is the transconductance. The feature of the OTA which makes it ideal for the VCF is that the transconductance  $g_m$  is determined by a control current  $I_{ABC}$ , thus  $g_m = k \cdot I_{ABC}$ , where  $k$  is a constant. This is illustrated in figure 2.

For the CA3080 OTA used in the Formant VCF the constant  $k$  is  $19.2 \text{ V}^{-1}$  at an ambient temperature of  $25^\circ \text{C}$ , and so  $g_m = 19.2 \times I_{ABC} \text{ mS}$  (milliSiemens = milliamps/volt). This IC is particularly suitable because of the outstanding linearity of its transconductance characteristic over three decades of control current, and because of its relatively small tolerance in the value of 'k' (2:1 for the 3080 and 1.6:1 for the 3080A). However good linearity is achieved only for small input signals, and the input voltage must be attenuated to about  $\pm 10 \text{ mV}$  when used in the

VCF.

Figure 3 shows the circuit of the integrator used in the Formant VCF. The input voltage is attenuated by the potential divider connected to the inverting input, and across the output is connected the  $180 \text{ p}$  integrating capacitor.

To maintain correct operation of the integrator the total output current of the OTA must flow into the integrator capacitor, which means that a buffer stage with a very high input impedance is required on the OTA output to avoid 'current-robbing'. A FET connected as a source-follower is used for this purpose.

The control current  $I_{ABC}$  is fed in through a  $27 \text{ k}$  resistor. The integrator time constant is inversely proportional to the control current, so the VCF centre/turnover frequency is directly proportional to the control current.

### Complete circuit of the VCF

Figure 4 shows the complete circuit of

the VCF. The actual filter circuit has a linear frequency characteristic and is current controlled. It must therefore be preceded by an exponential converter that converts the input control *voltage* into an exponentially related control *current*, so that the VCF tracks with the same 1 octave/V characteristic as the VCOs.

The exponential converter occupies the upper portion of the circuit, and is essentially similar to that of the VCOs. However, the control characteristic of the VCF does not need to be so accurate as that of the VCO, since a small error will only introduce minor, unnoticeable errors in amplitude response, whereas the same error in the VCO characteristic would cause unacceptable tuning errors.

For this reason the VCF exponential converter is provided only with a passive input adder (cf. figure 2a of the last chapter), and temperature stabilisation of the exponentiator is dispensed with, thus saving the cost of a not in-

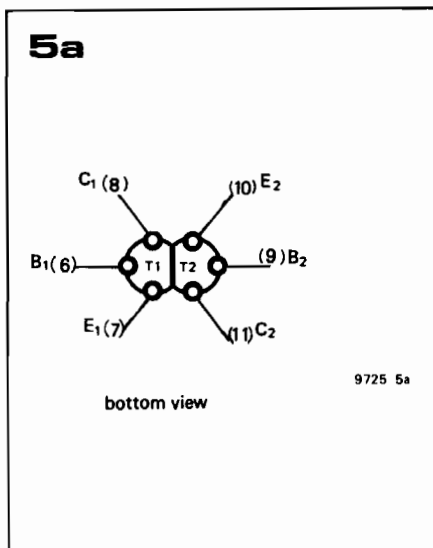
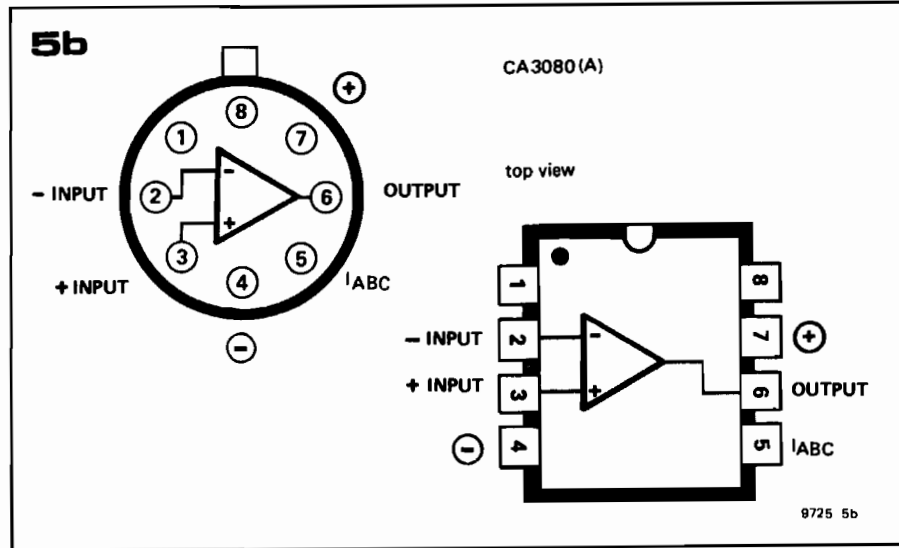

Figure 4. Complete circuit of the Formant VCF, which consists of a voltage-current exponential converter and a linear current-controlled filter.

Figure 5a. Two well-matched PNP transistors may be used in place of IC1 for greater economy. The pin numbers shown correspond to the pinout of IC1.

Figure 5b. The CA 3080 is available in two packages. If the TO- package is used the leads must be bent to fit the DIP layout on the p.c.b.



was used in the prototype, but if this is difficult to obtain then almost any dual PNP transistor, such as the Analog Devices AD 820... AD 822, Motorola 2N3808... 2N3811 or SGS-ATES BFX 11, BFX 36, will do.

Note that the value shown for R6 (1k8) is correct when using the CA 3084. If a dual transistor is used, it is advisable to reduce the value of R6 to 1k5.

The current-controlled filter consists of IC3, IC4 and IC5. It will be noted that the integrators IC4 and IC5 are non-inverting. This does not affect the operation of the circuit, since non-inversion has the same effect as the double inversion that takes place in figure 1. However, it does ensure that the three outputs of the filter are in the same sense, whereas in figure 1 the bandpass output is inverted with respect to the other two outputs.

IC6 functions as an output buffer, and also as a summing amplifier for the high-pass outputs to provide the notch function. By setting S2, S3 or S4 in position 'a', highpass, lowpass or bandpass functions respectively may be selected. By setting both S2 and S4 in position 'a' the notch function is obtained. Since IC3 is connected as an inverting amplifier and IC6 also inverts, this double inversion means that the output signal is non-inverted with respect to the input signals. The overall gain of the VCF (in the passband) is  $x \ 1 \ (0dB)$ .

### Inputs, controls and outputs

The exponential converter section is equipped with a coarse octave tuning control P1 (note the absence of a fine control as compared with the VCO) and two presets P7 and P8 to adjust the offset and octave/V characteristic.

KOV and ECV control inputs are provided, as for the VCO. The input for envelope shaper control (ENV) is adjustable by means of P2. The tone colour modulation input controlled by P3/(TM) is analogous to the FM input of the VCO, i.e. it allows the centre/turnover frequency of the VCF to be modulated. There are four signal inputs, three internally-wired VCO inputs and one external

signal (ES) input, whose amplitude can be controlled by P4. The Q-factor of the filter is controlled by P5.

Switches S2 to S4 select the desired filter type, as has already been described. Two outputs are provided, an uncontrolled output EOS which is brought out to a front-panel socket, and an internal output IOS, which is controlled by P6.

### Construction

A printed circuit board and component layout for the VCF are given in figure 6. The same considerations of component quality apply to the VCF that apply to all parts of the synthesiser. As mentioned earlier, two basic versions of the CA 3080 are available. The CA 3080A has better specifications as regards tolerance, and extended temperature range, but the basic CA 3080 is quite adequate (assuming that the synthesiser is not to be used in Antarctic blizzards).

The CA 3080 is available in two packages, TO- can and mini-DIP, both of which are shown in figure 5b. The p.c. board is laid out for the mini-DIP version, but the TO- version can easily be accommodated by splaying out the leads to conform with the mini-DIP pinning (in fact some TO- package 3080s are supplied with this already done).

The FETs T1 and T2 must be tested as detailed in chapter 3 and their source resistors R23 and R27 selected in accordance with Table 1 of that chapter. A front panel layout for the VCF is given in figure 7, and a wiring diagram for the front-panel mounted components is shown in figure 8.

### Testing and adjustment

During assembly, it is convenient to use IC sockets so that the current-controlled filter section of the circuit can be tested independently of the exponential converter. To test the CCF, IC1 is removed and a 100k log potentiometer is connected 'back-to-front' between ground and -15V (i.e. so that the end of the track approached by clockwise rotation of the wiper is connected to ground).

A multimeter set to the 100  $\mu A$  range is

expensive  $\mu A726$  IC. However, temperature compensation is retained in the form of a matched transistor pair. The circuit differs here from the VCO since the exponentiator must source current into the OTAs rather than sinking it as in the VCO, so PNP transistors are used.

Since temperature stabilisation is not used, a number of options are open for the choice of the matched transistor pair. Those who have access to a good transistor tester or curve tracer can select a matched pair of any small signal medium gain ('B' spec) transistors such as the BC 179B, BC 159B, BC 557B etc. These are then glued together with epoxy adhesive for good thermal tracking as shown in figure 5a, taking care that there is no electrical contact between the cases if metal-can types are used. (Note that the pin numbers given in figure 5a correspond to the IC pinning in figure 4).

The preferred solution is to use a CA 3084 transistor array, which is what

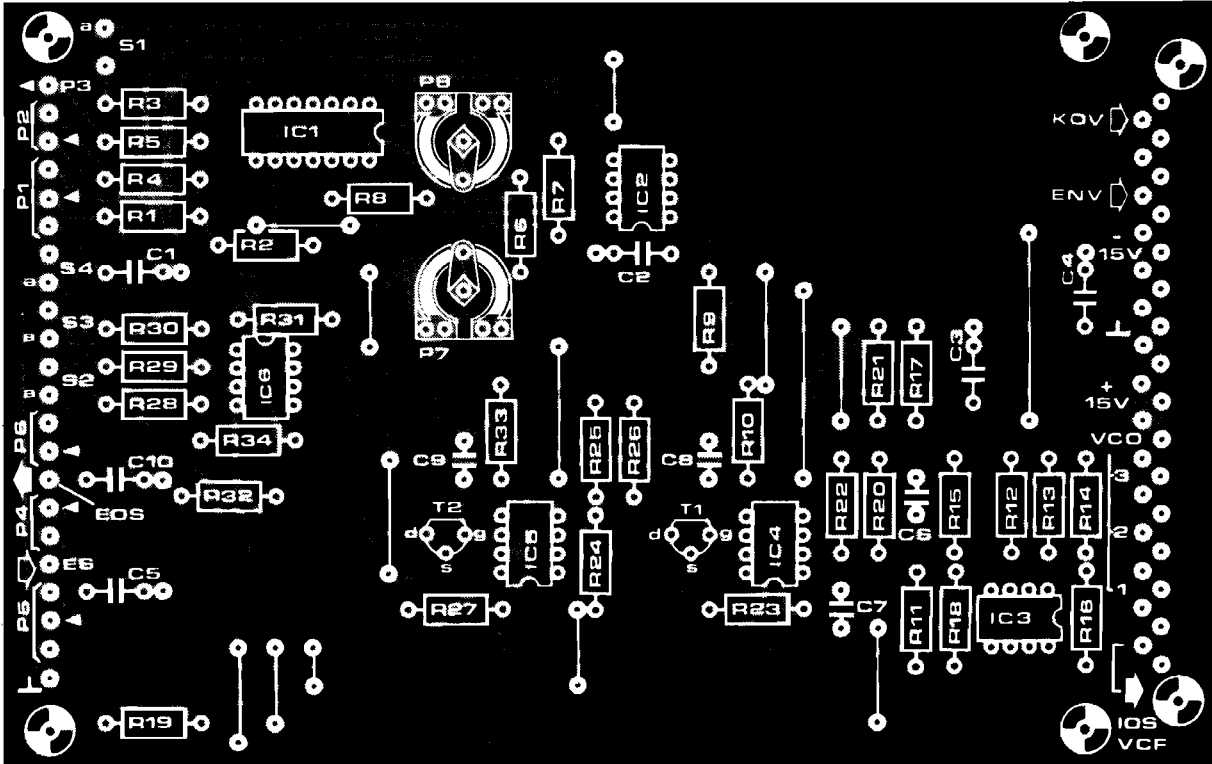
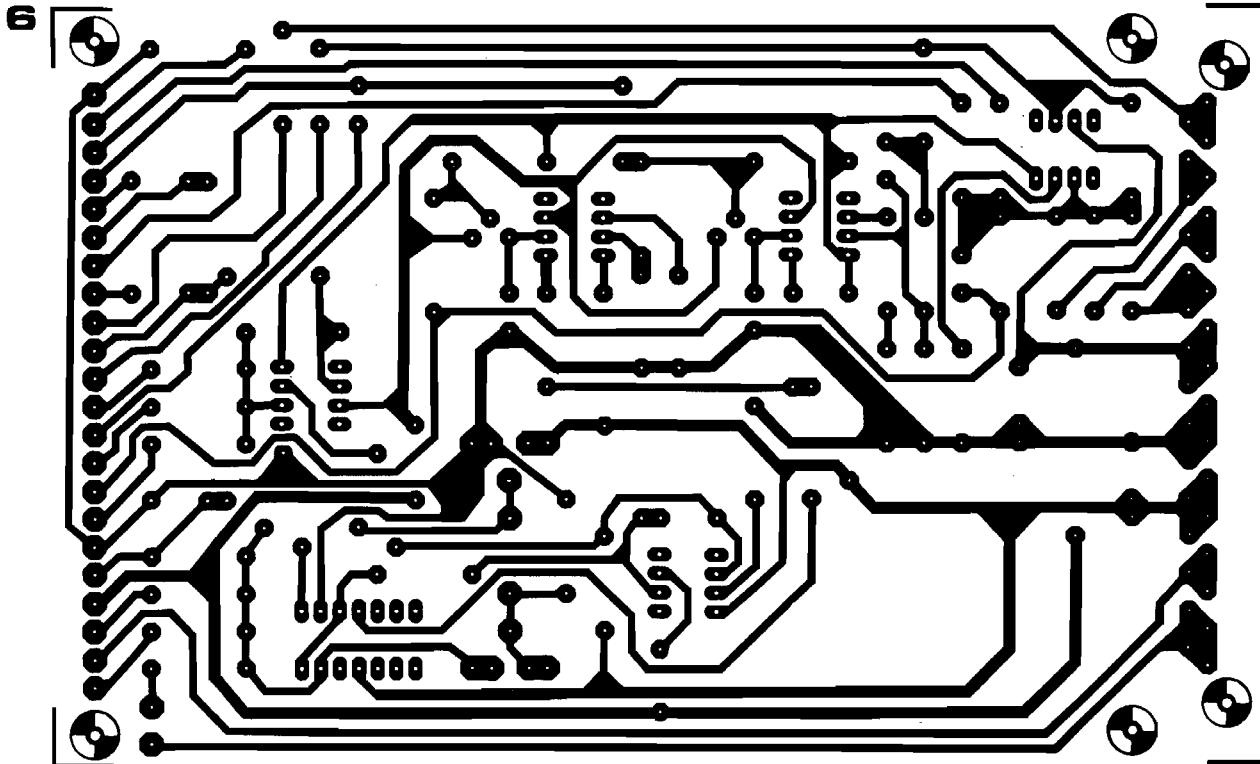

**Parts List**

**Resistors:**

- R1, R2, R28, R29,
- R30, R34 = 100 k
- R3 = 100 k (1% metal oxide)
- R4 = 33 k
- R5 = 47 k
- R6 = 1k8 (see text)
- R7, R9 = 330 k
- R8 = 2k2
- R10, R33 = 27 k
- R11, R12, R13, R14,
- R15, R16, R20, R24 = 39 k
- R17 = 8k2
- R18 = 22 k

- R19 = 1 k
  - R21, R22, R25, R26 = 100  $\Omega$
  - R23, R27 = 12 k (nominal value, see text)
  - R31 = 33 k
  - R32 = 470  $\Omega$
- Potentiometers:**
- P1, P5 = 100 k lin
  - P2, P3 = 47 k (50 k) lin
  - P4 = 47 k (50 k) log
  - P6 = 4k7 (5 k) log
- Presets:**
- P7 = 100 k
  - P8 = 470  $\Omega$  (500  $\Omega$ )

**Capacitors:**

- C1, C3, C4, C5, C10 = 680 n
- C2 = 1 n
- C6, C7 = 33 p
- C8, C9 = 180 p

**Semiconductors:**

- IC1 = CA 3084 (DIL) see text.
- IC2, IC3, IC6 =  $\mu$ A 741 C (Mini DIP), MC1741 CP1 (Mini DIP).
- IC4, IC5 = CA 3080 (A)
- T1, T2 = BF 245a, b.

**Miscellaneous:**

- 31-way plug (DIN 41617)
- S1 - S4 = miniature SPDT toggle switch

Figure 6. Printed circuit board and component layout for the VCF. (EPS 9724-1).

connected between the wiper of the potentiometer and the junction of R10 and R33, an input signal is provided to the VCF from a sinewave generator or from the VCO, and the Bandpass output is monitored on an oscilloscope. The test then proceeds as follows:

1. Set the Q-factor of the filter to maximum (wiper of P5 turned towards R19).
2. By means of the 100k log potentiometer set the control current to 50  $\mu$ A on the meter.
3. Slowly increase the generator frequency from about 300 Hz to 1500 Hz; somewhere in this range the VCF output should peak as its resonant frequency is reached (i.e. there will be a sharp increase in output at a particular frequency with a fall-off on each side). Note the frequency at which resonance occurs.
4. Increase the control current to 100  $\mu$ A and check that resonance now occurs at twice the previously noted frequency.

Note. Tests 2 to 4 are intended to check the linearity of the filter frequency v. control current characteristic. The tolerance in the absolute value of filter frequency for a given control current is due to OTA tolerances and is unimportant provided linearity is maintained i.e. the filter frequency doubles for each doubling of control current.

5. Set the generator to about 50 Hz and check that it is possible to obtain resonance at this frequency by varying the control current with the 100 k potentiometer. Repeat this test at 15 kHz.

The exponential converter can now be tested after inserting IC1 and removing IC4 and IC5. A multimeter set to the 100  $\mu$ A range is connected from the bottom end of R10 to -15V and the wiper voltage of P1 is monitored with a voltmeter.

The test and adjustment now proceed as follows:

1. Set P8 to its mid-position, and turn P1 fully anticlockwise so that its wiper voltage is zero. Adjust P7 until the microammeter reading is 50  $\mu$ A.
2. Turn P1 clockwise until its wiper voltage is 1V, then adjust P8 until the microammeter reads 100  $\mu$ A.
3. Repeat the procedure for 2V, 3V, 4V etc. on the wiper of P1, checking that the exponentiator output current doubles for every 1V increase.

#### Offset adjustment

Now that the two sections of the VCF have been checked, IC4 and IC5 can be re-inserted so that the entire VCF can be checked as a functional unit, as follows:

1. A squarewave with 50% duty-cycle at a frequency of about 500 Hz is fed to one of the filter inputs. P1 is turned fully clockwise and P7 is turned anticlockwise.
2. The lowpass output of the VCF is

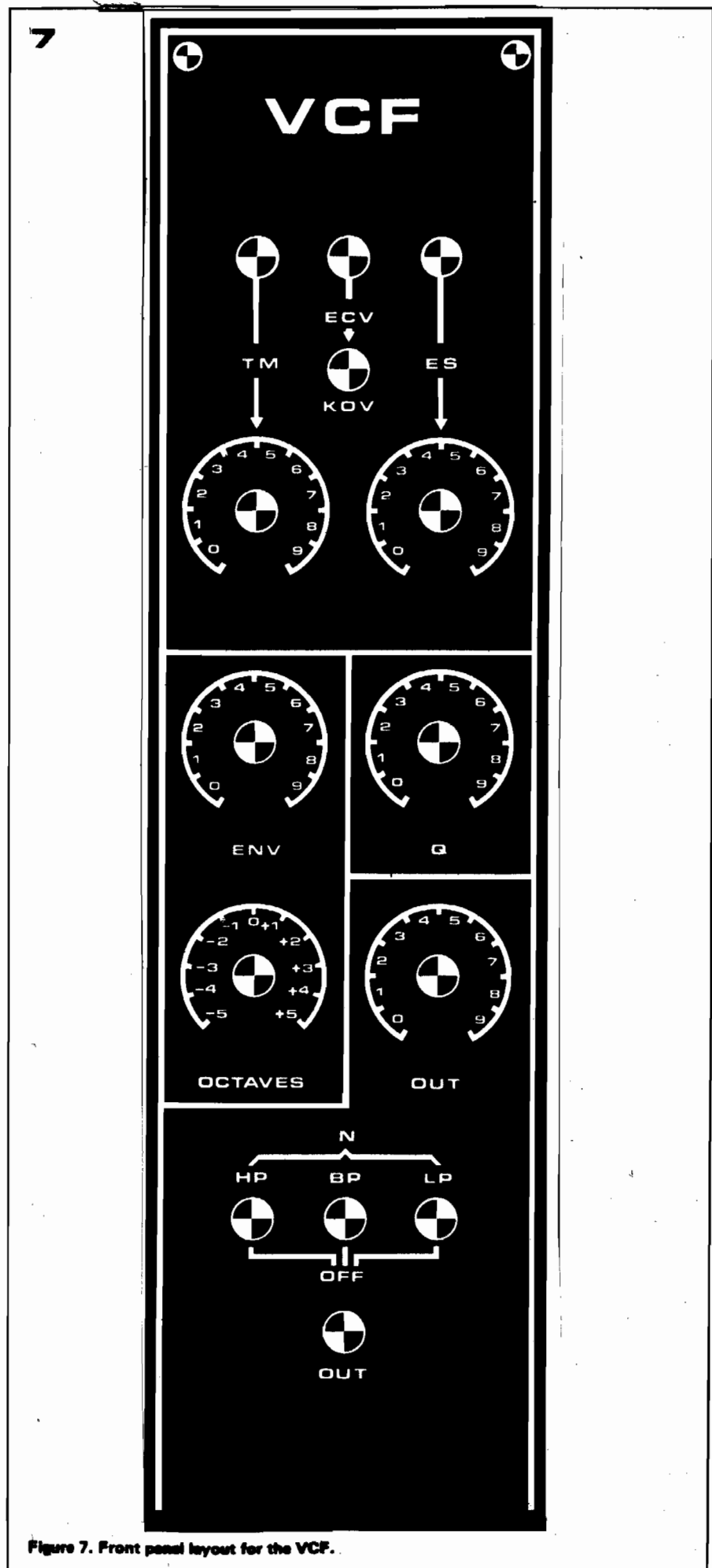

Figure 7. Front panel layout for the VCF.

8

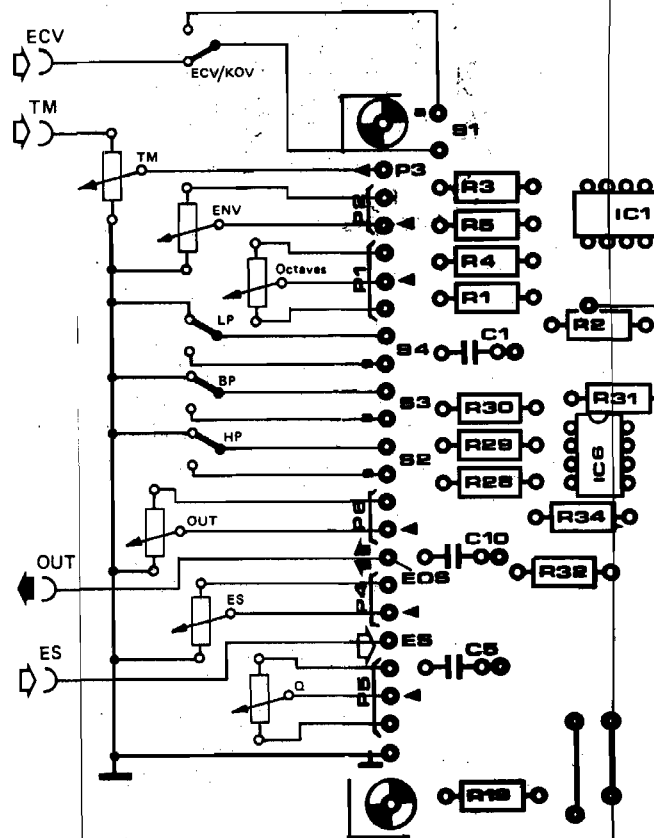

Figure 8. Wiring diagram for the panel mounted components.

monitored on an oscilloscope, and at this stage should appear at the output without degradation.

3. If the wiper of P7 is now turned slowly clockwise the leading edge of the squarewave will start to be rounded off as the turnover point of the filter is reduced. To carry out the offset adjustment with P7 its wiper is turned as far clockwise as is possible without significantly degrading the square waveform (just a slight rounding of the top corner is acceptable, but this adjustment does not have to be particularly precise).

**Octaves/Volt adjustment**

The octave/V characteristic of the VCF can be adjusted by seeing how well it tracks against a previously calibrated VCO. To do this, the KOV input is connected to the VCO and the VCF, and the sine output of the VCO is connected to the VCF input. The adjustment procedure is as follows:

1. Switch off the main tuning of the keyboard, depress top C of the keyboard and use the octaves control of the VCO to set its frequency to about 500 Hz.
2. Set the Q control, P5, of the VCF to maximum, monitor the bandpass output of the VCF and adjust P1 until the VCF output peaks. As the filter is loaded at high Q-factors it may be necessary to reduce the VCO output voltage.
3. Depress the key two octaves lower and adjust P8 until the VCF output again peaks.
4. Depress top C again and if necessary

readjust P1 so that the output peaks.

5. Repeat 3 and 4 until no further readjustment is necessary for the output to peak when changing from one note to the other.
6. The offset adjustment may have been disturbed, so check this and if necessary readjust P7 as described in the offset adjustment procedure.
7. Repeat 3 onwards until no further improvement can be obtained.

**Bibliography**

- S. Franco: 'Use transconductance amplifiers to make programmable active filters.' - *Electronic Design*, September 13th, 1976.
- T. Orr: 'Voltage/current-controlled filter.' - *Circuit Ideas, Wireless World*, November 1976.
- E. F. Good and F. E. J. Girling: 'Active filters, 8. The two-integrator loop, continued.' - *Wireless World*, March 1970.
- D. P. Colin: 'Electrical design and musical application of an unconditionally stable combined voltage-controlled filter resonator.' - *JAES*, December 19th 1971.
- G. J. Clayton: 'Experiments with operational amplifiers. 4. Operational Integrators.' - *Wireless World*, August 1972.
- H. A. Wittlinger: 'Anwendung der CA 3080 und CA 3080A.' - *RCA Applicationsschrift ICAN-6668*, 1973.
- U. Tietze, Ch. Schenk: 'Einstellbares universelles Filter.' *Halbleiter Schaltungstechnik*, p. 350. Springer-Verlag, Berlin, Heidelberg, New York, 1976.

chapter 7

**24 dB VCF**

Because of the greater range of tonal possibilities they offer, VCFs with an extremely steep slope seem to have a particular appeal for most synthesiser enthusiasts. The design presented here is for a VCF offering a choice of lowpass or highpass functions and a filter slope of 6, 12, 18 or 24 dB per octave.

**New possibilities**

It should be stated at the outset that the 24 dB VCF is not intended to replace the 12 dB design. On the contrary, the two filters are complementary to one another and can be used in combination to provide greatly increased possibilities for tailoring the harmonic structure of the sounds produced by Formant.

For example, the 12 dB VCF can be used in the bandpass mode together with the steep filtering of the 24 dB VCF to produce selective tone coloration. The two filters can be controlled by the same envelope shaper or by different envelope shapers, and may be connected in cascade or in parallel. The latter arrangement offers several interesting possibilities. For example, hard, metallic sounds can be produced by applying a short, steep envelope voltage to the 12 dB VCF and a longer, shallower contour to the 24 dB VCF.

If the filter inputs are connected in parallel then interesting effects may be obtained by connecting one VCF output to one input of a stereo amplifier and the other VCF output to the other input. This gives rise to a very distinctive dynamic amplitude characteristic and stereo imaging, particularly if the two VCFs are controlled by different envelope shapers.

The audible differences between the 12 dB VCF and the 24 dB VCF are quite prominent. The 12 dB VCF produces sounds that are distinctly 'electronic', which can have a slightly fatiguing effect on the listener during extended playing sessions. The sounds produced by the 24 dB VCF, on the other hand, are much more 'natural', and can be listened to for extended periods without fatigue. This effect is probably due to the more severe filtering of higher harmonics which the 24 dB VCF provides when used in the lowpass mode, since these harmonics tend to make the sound of the 12 dB VCF much more shrill than that of the 24 dB VCF.

The effect of the steeper filter slope of the 24 dB VCF is illustrated in figure 1, which shows the different outputs from the 12 dB VCF (dotted line) and 24 dB

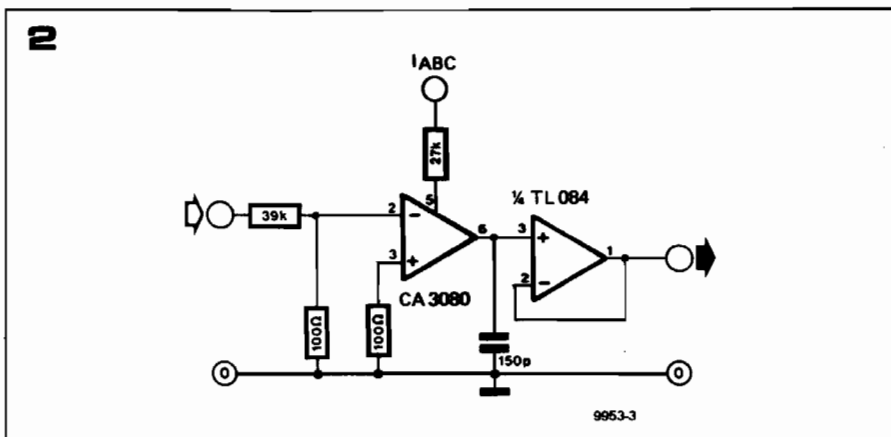
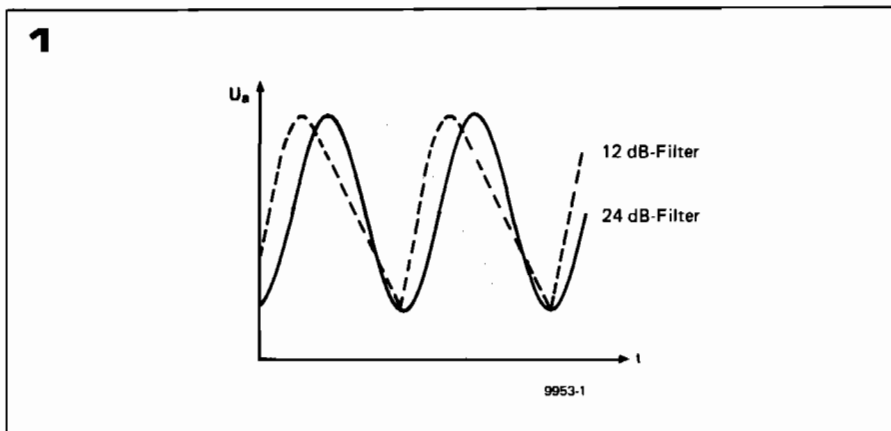

Figure 1. This illustrates the difference between the outputs of a 12 dB/octave VCF and a 24 dB/octave VCF having the same turnover frequency, when fed with a sawtooth input. The 24 dB VCF removes practically all the harmonics giving a sinewave output, whereas the original waveshepe is still distinguishable at the output of the 12 dB VCF.

Figure 2. The basic filter section of the 24 dB VCF is the same as that of the 12 dB VCF, i.e. an OTA integrator followed by a FET op-amp buffer.

Figure 3. The highpass function is obtained by connecting the 6 dB lowpass section in the feedback loop of an operational amplifier.

Figure 4. To obtain a 24 dB/octave filter, four 6 dB/octave sections are cascaded.



VCF (continuous line) when fed with a sawtooth waveform. It is apparent that, due to the almost complete removal of the harmonics of the sawtooth, the output of the 24 dB VCF is practically a sinewave, whereas the original waveform is still apparent at the output of the 12 dB VCF since the harmonics are only partially removed.

It is clear from the foregoing that a 24 dB VCF greatly extends the musical possibilities of a synthesiser and is virtually a must for the serious user.

**Design of the 24 dB VCF**

The design of the basic filter section shown in figure 2 is very similar to that of the 12 dB VCF, which was described in detail in the previous chapter. However, advantage has been taken of recent developments in FET op-amp technology to simplify the design slightly. As has been explained, the basic filter section is an integrator or 6 dB/octave lowpass section consisting of an OTA driving a capacitor. The voltage/current transconductance ( $g_m$ ) of the OTA can be varied by an external control current and hence, via an exponential voltage/current converter, from an external control voltage. This control current alters the time constant of the integrator and hence the turnover frequency of the filter section.

The output current of the OTA must all flow into the capacitor, otherwise the integrator characteristic will be less than ideal. This means that the output of the OTA must be buffered by an amplifier with a high input impedance. In the

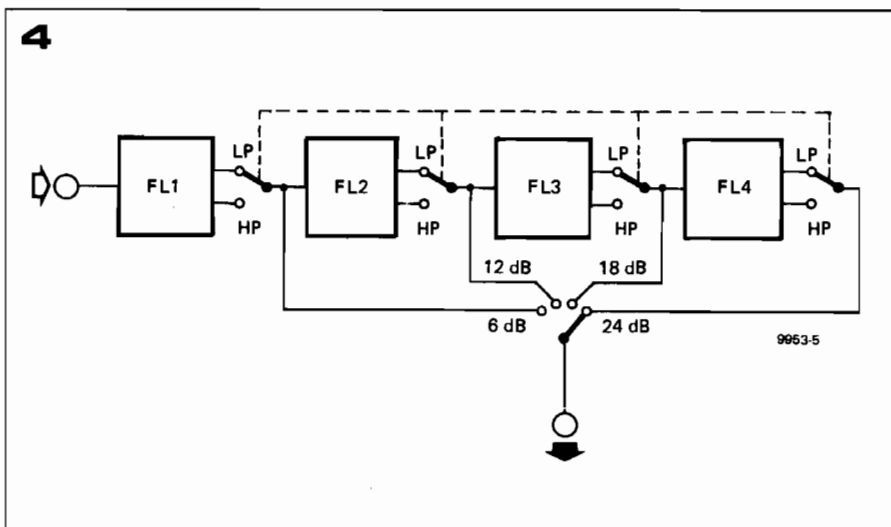
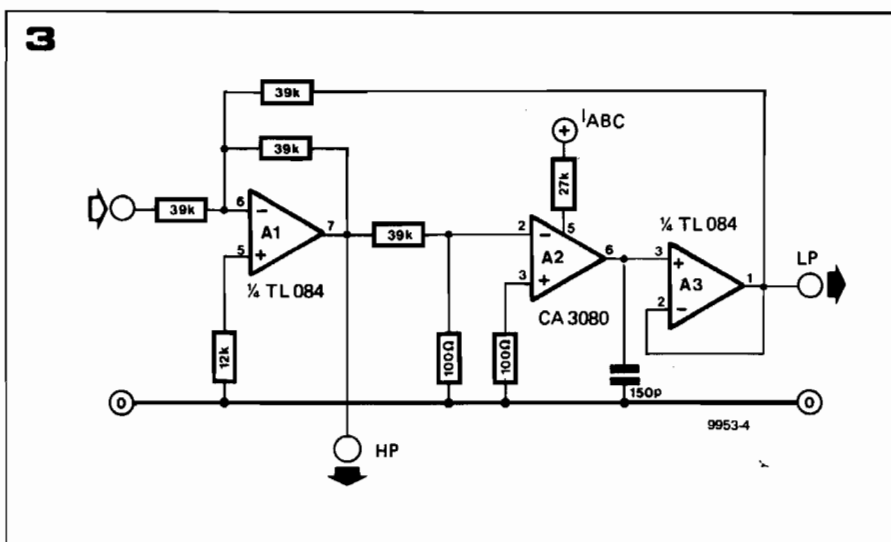

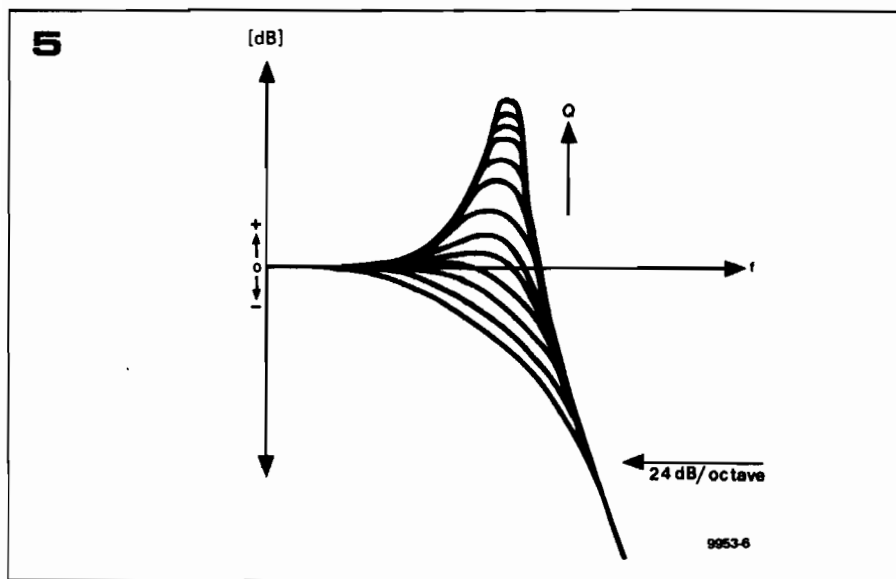
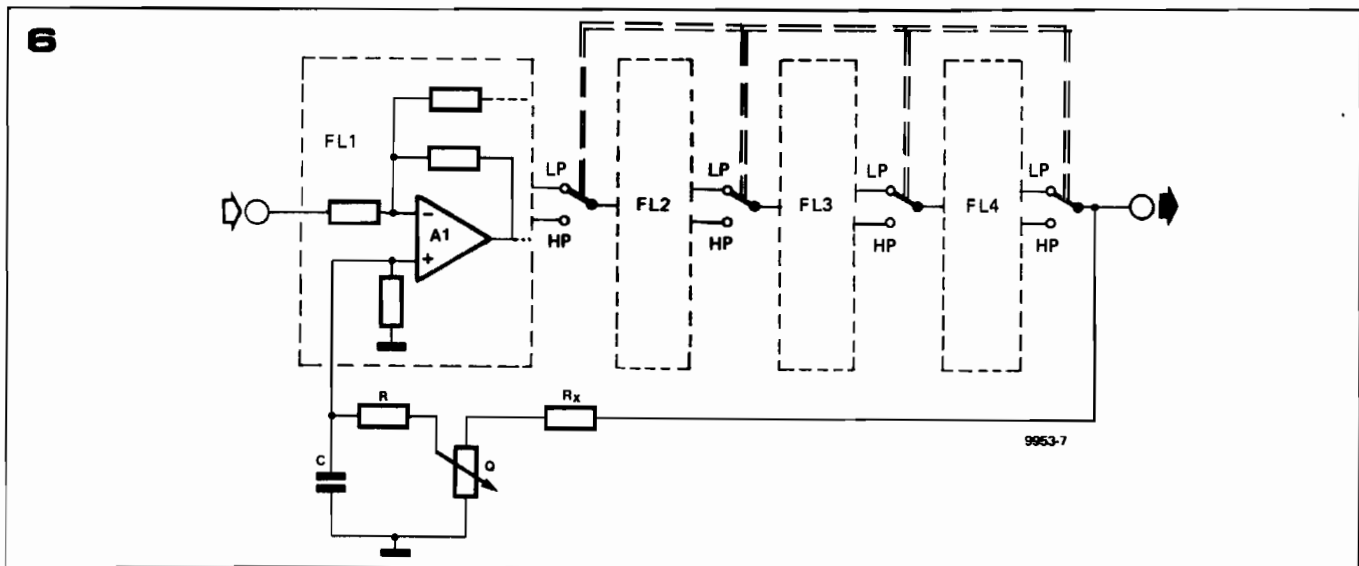

Figure 5. Positive feedback around the entire filter allows the response to be boosted about the turnover frequency. The degree of boost can be varied by a 'Q' control.

Figure 6. Block diagram of the 24 dB/octave filter, showing how the Q control is incorporated.

Figure 7. Complete circuit of the 24 dB VCF. The exponential voltage/current converter is identical to that used in the 12 dB VCF.



12 dB VCF this was achieved by using a discrete FET source follower and a 741 op-amp. Fortunately, relatively inexpensive quad FET op-amps such as the Texas TL084 are available. The use of one of these ICs simplifies the design and obviates the need to select FETs, which becomes something of a chore when one considers that the 24 dB VCF uses four integrator stages.

### Highpass function

The highpass mode of the filter is achieved by connecting the 6 dB/octave lowpass section in the negative feedback loop of an operational amplifier, A1, as shown in figure 3. A highpass filter response is then available at the output of A1 whilst a lowpass response is simultaneously available at the output of A3. Of course, this arrangement gives only a 6 dB/octave slope per section, and in order to obtain a 24 dB/octave filter four filter sections, built according to the circuit of figure 3, must be cascaded as shown in figure 4. Switching at the output of each section allows selection of highpass or lowpass mode, whilst a 4-position switch allows 1, 2, 3, or 4 filter sections to be switched in to give 6-, 12-, 18-, or 24 dB/octave slopes

respectively.

It is apparent that this arrangement is different from the two-integrator loop or state-variable filter which formed the basis of the 12 dB/octave filter. In the 12 dB/octave filter, lowpass, highpass, bandpass and notch modes were available simultaneously at various points in the circuit, though in fact only one function at a time could be selected at the output.

An interesting effect, shown in figure 5, can be obtained with the 24 dB VCF if a feedback loop is connected from the output of the cascaded filters to the non-inverting input of the first stage as illustrated in figure 6. Due to the phase shift around the turnover frequency this causes positive feedback, which boosts the gain of the filter around the turnover frequency as shown in figure 5. The degree of boost is adjustable by means of a 'Q' control. The choice of  $R_x$  is important as too much feedback would cause the circuit to oscillate, so the value of  $R_x$  is a compromise between stability and a reasonable degree of boost.

### Complete circuit

The complete circuit of the 24 dB VCF

is given in figure 7. The exponential converter, constructed around T1, T2 and IC1, is identical to that used in the 12 dB VCF and gives the same 1 octave per volt characteristic to the turnover frequency of the filter. The control voltage inputs are also the same as for the 12 dB VCF, and are listed in table 1.

Since the 24 dB VCF must have the option of being connected in parallel or in cascade with the 12 dB VCF, the input switching arrangements are a little complicated. A9 and A10 form a non-inverting summing amplifier for the three VCO inputs, whilst the output of the 12 dB VCF is fed in via the IS connection. With S4 in position 2 the output of A10 is disconnected, so the VCO inputs are inhibited. The output of the 12 dB VCF is fed to the input of the 24 dB VCF via S4 and R51, so that the two VCFs are in cascade.

With S4 in position 1 the output of A10 is connected to the inputs of the 24 dB VCF, whilst the output of the 12 dB VCF is routed through A11. The output of A11 and the output of the 24 dB VCF are added together in the output summing amplifier A12, i.e. the two VCFs are connected in parallel.

The four 6 dB/octave filter sections

7a

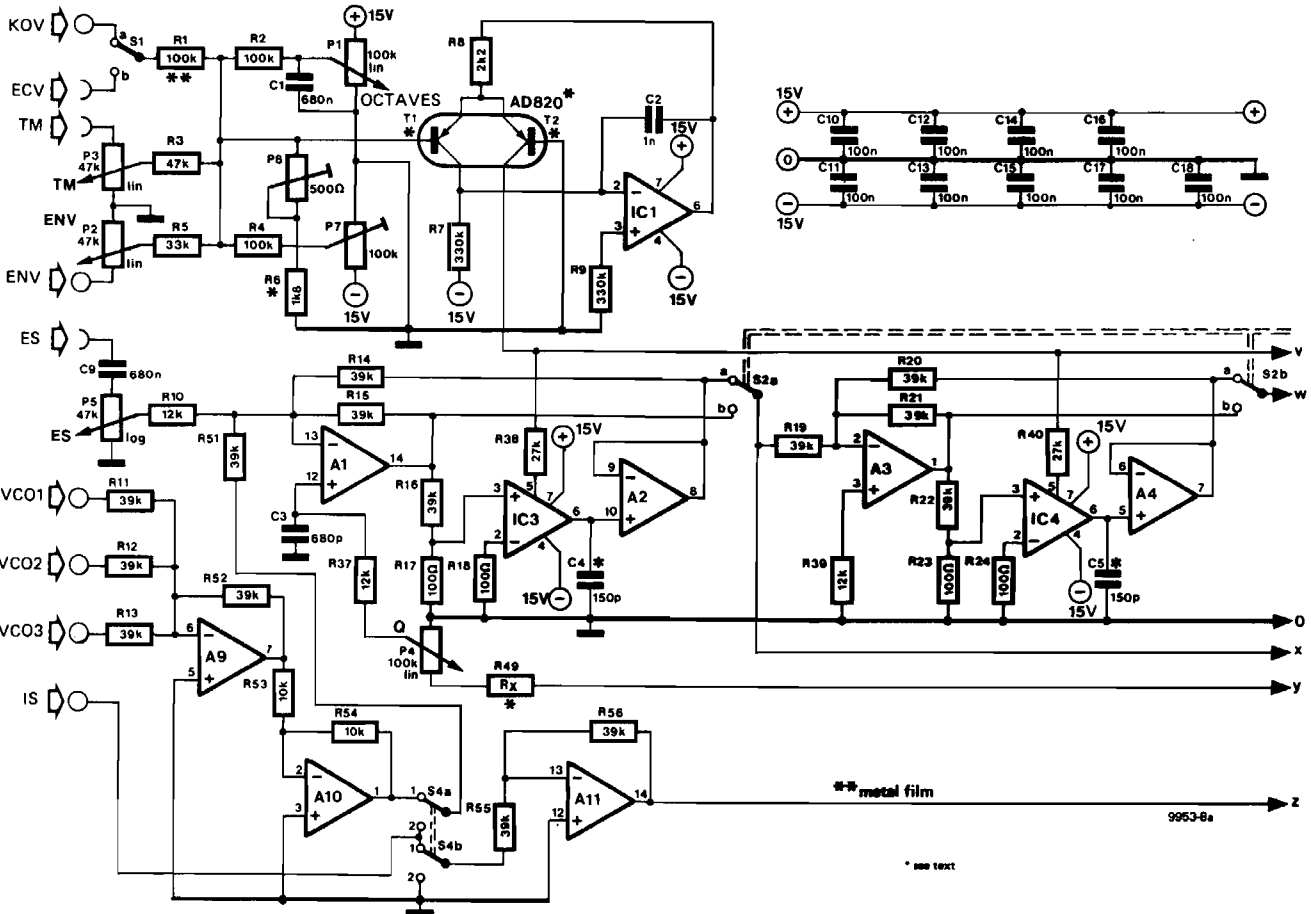

7b

A1 + A2 + A3 + A4 = IC2 = TL 084  
 A5 + A6 + A7 + A8 = IC5 = TL 084  
 A9 + A10 + A11 + A12 = IC8 = TL 084  
 IC1 =  $\mu$ A 741 Minidip  
 IC3 = CA 3080\*  
 IC4 = CA 3080\*  
 IC6 = CA 3080\*  
 IC7 = CA 3080\*

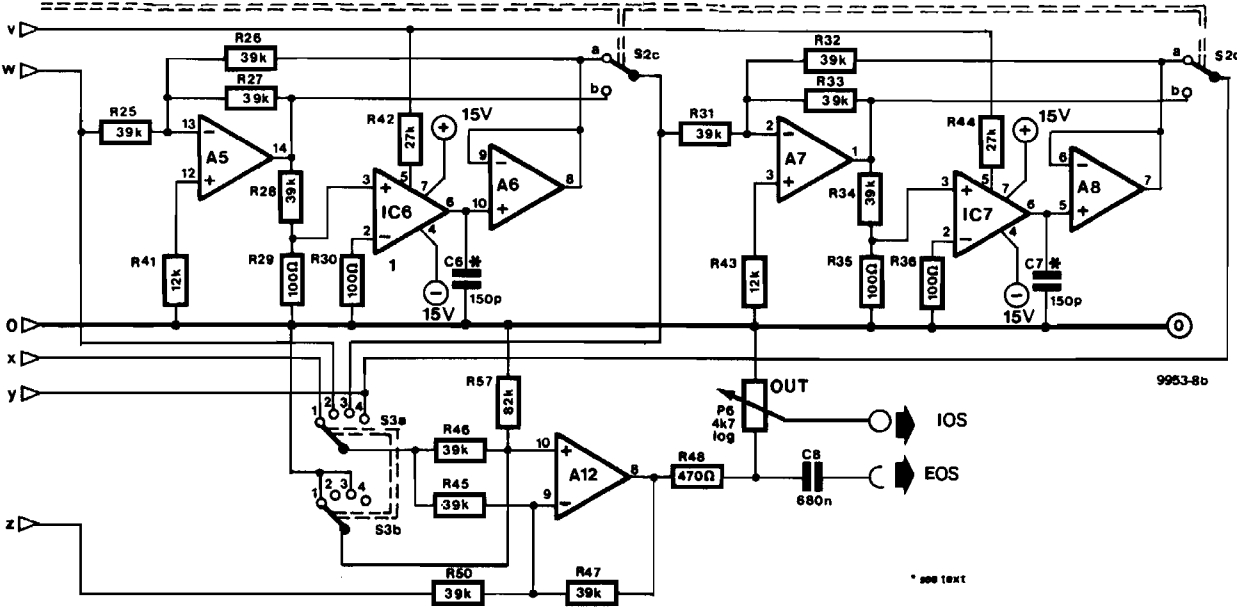

\* see text

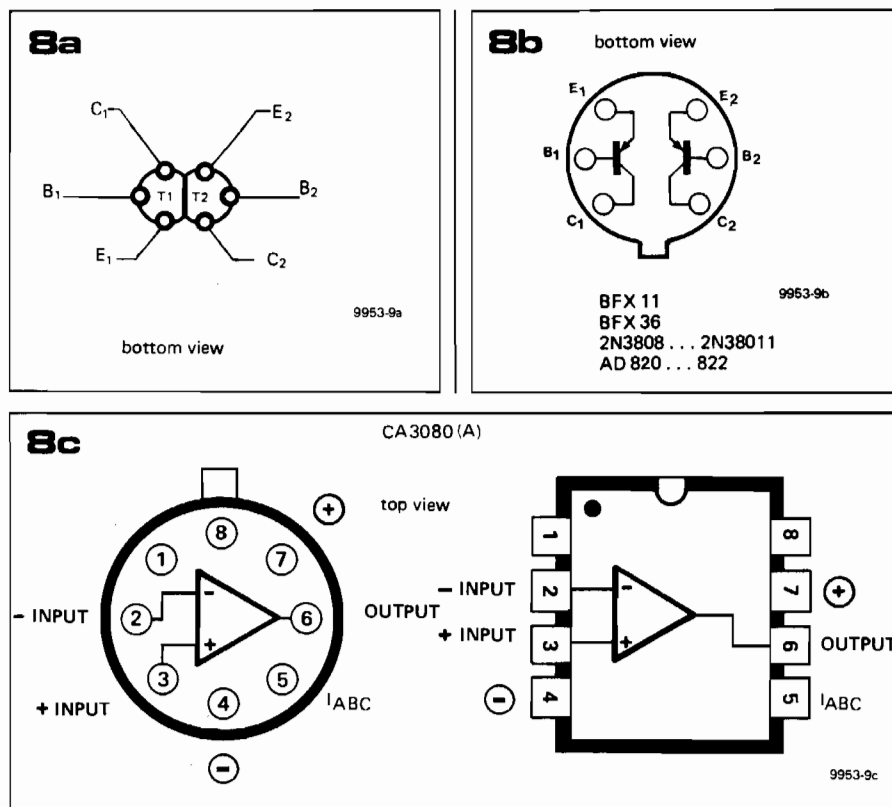

comprise A1 to A8 and IC3 to IC7. The four poles of switch S2 select between highpass and lowpass modes, while S3 selects the filter output and hence the slope. The reason that S3 is a two-pole switch may not be immediately apparent, but is easily explained. Ignoring the phase shift introduced by the action of the filter, i.e. considering only signals in the filter passband, each filter section inverts the signal fed to it, since A1, A3, A5 and A7 are connected as inverting amplifiers. This means that the outputs of alternate filter sections are either in phase or inverted with respect to the input signal. To ensure that the filter output is in the same phase relationship to the input signal whatever filter slope is selected, S3b is arranged to switch A12 between the inverting and non-inverting modes to cancel the inversions produced by the filter sections.

Like the 12 dB VCF, the 24 dB VCF has two outputs, a hardware output connection IOS and an uncommitted output, EOS, which is connected to a front panel socket.

### Construction

As far as the choice of components for the 24 dB VCF goes, the same general comments apply that were made about the 12 dB VCF and the Formant synthesiser in general. All components should be of the highest quality; resistors should be 5% carbon film types except where metal oxide or metal film types are specified; capacitors should preferably be polyester, polystyrene or polycarbonate, and must be these types where specified. Semiconductors should be from a reputable manufacturer.

As with the 12 dB VCF the dual transistor may be any of the types specified in

**Figure 8. Pinouts for the dual transistors and CA3080.**

**Figure 9. Printed circuit board and component layout for the 24 dB VCF. (EPS 9953-1).**

**Table 1. Summary of the control functions and input/output connections of the 24 dB VCF.**

Table 1	
a) hardwired inputs (not on the front panel)	
KOV	= Keyboard Output Voltage (from interface receiver)
ENV	= Envelope shaper Control Voltage (from ADSR unit)
VCO 1,2,3	= Signals from VCOs 1, 2, 3
IS	= Internal signal from the 12 dB VCF
b) external inputs (sockets on front panel)	
ECV	= External Control Voltage (for exponential generator of the VCF)
TM	= Tone Colour Modulation input
ES	= External Signal (from e.g. noise module)
c) outputs	
IOS	= Internal Output Signal (from VCF to VCA)
EOS	= External Output Signal (socket on front panel)
d) controls	
TM	= P3; sets tone colour modulation level
ES	= P5; sets external signal level
ENV	= P2; sets envelope shaper control voltage
OCTAVES	= P1; coarse frequency adjustment
Q	= P4; sets level of peak boost around turnover frequency
OUT	= P6; sets IOS output level
e) switches	
ECV/KOV	= S1; selects external or internal control voltage input

### Parts list to figures 8 and 10

#### Resistors:

R1 = 100 k metal oxide  
 R2, R4 = 100 k  
 R3 = 47 k  
 R5 = 33 k  
 R6 = 1k8  
 R7, R9 = 330 k  
 R8 = 2k2  
 R10, R37, R39, R41, R43 = 12 k  
 R11 ... R16, R19 ... R22,  
 R25 ... R28, R31 ... R34, R45,  
 R46, R47, R50, R51, R52, R55,  
 R56 = 39 k  
 R17, R18, R23, R24, R29, R30,  
 R35, R36 = 100 Ω  
 R38, R40, R42, R44 = 27 k  
 R48 = 470 Ω  
 R49 = 100 k (see text)  
 R53, R54 = 10 k  
 R57 = 82 k

#### Potentiometer:

P1, P4 = 100 k linear  
 P2, P3 = 47 k (50 k) linear  
 P5 = 47 k (50 k) logarithmic  
 P6 = 4k7 (5 k) logarithmic  
 P7 = 100 k preset  
 P8 = 470 Ω (500 Ω) preset

#### Capacitors:

C1, C8, C9 = 680 n  
 C2 = 1 n  
 C3 = 680 p (polystyrene, not ceramic)  
 C4, C5, C6, C7 = 150 p (polystyrene, not ceramic)  
 C10 ... C18 = 100 n

#### Semiconductors:

IC1 = 741  
 IC2, IC5 = TL 084, TL 074  
 IC8 = TL 084, TL 074, LM 324  
 IC3 ... IC6 = CA 3080,  
 CA3080A (MINIDIP or TO;  
 see text)  
 T1, T2 = AD 820 ... 822,  
 2N3808 ... 3811, BFX 11,  
 BFX 36 (see text) or  
 2 x BC 557B

#### Miscellaneous:

31-pin DIN 41617 connector or terminal pins  
 S1 = SPDT  
 S2 = 4-pole double throw  
 S3 = 2-pole 4-way; index angle approx. 30°  
 S4 = DPDT  
 4 miniature sockets, 3.5 mm dia.  
 7 13 ... 15 mm collet knobs with pointer (to match existing synthesiser modules).

the parts list, or may be home-made by gluing together two normal transistors, though in this case thermal tracking will not be quite so good. The CA3080 should preferably be in a MINIDIP package to fit the hole spacings on the p.c. board, though the metal can type can be made to fit by splaying the leads. The pinouts for the dual transistors and the CA3080 are given in figure 8.

Although not absolutely necessary, it is a good idea to select OTA's with approximately the same transconductance,

since the four sections of the filter will then have almost the same turnover frequency. The CA3080 is available in two versions, the standard version, in which the ratio between the maximum and minimum  $g_m$  is 2:1, and the CA3080A, in which the spread in  $g_m$  is only 1.6:1. A test circuit and test procedure for selecting ICs with similar  $g_m$  are given at the end of the chapter and it is certainly worthwhile buying a few extra OTAs and selecting the four with the most similar  $g_m$ . The 'reject' devices are per-

fectly acceptable for use in the 12 dB VCF or VCA, and need not be wasted. The other ICs in the circuit should all be TL074 or TL084 quad BIFET op-amps, although for IC8 it is permissible to use an LM324. Thanks to the use of quad op-amps it is possible to accommodate the 24 dB VCF on a standard Eurocard-size (160 mm x 100 mm) p.c. board, although the control connections are not all on the front edge of the board. The printed circuit pattern and component layout for this board are

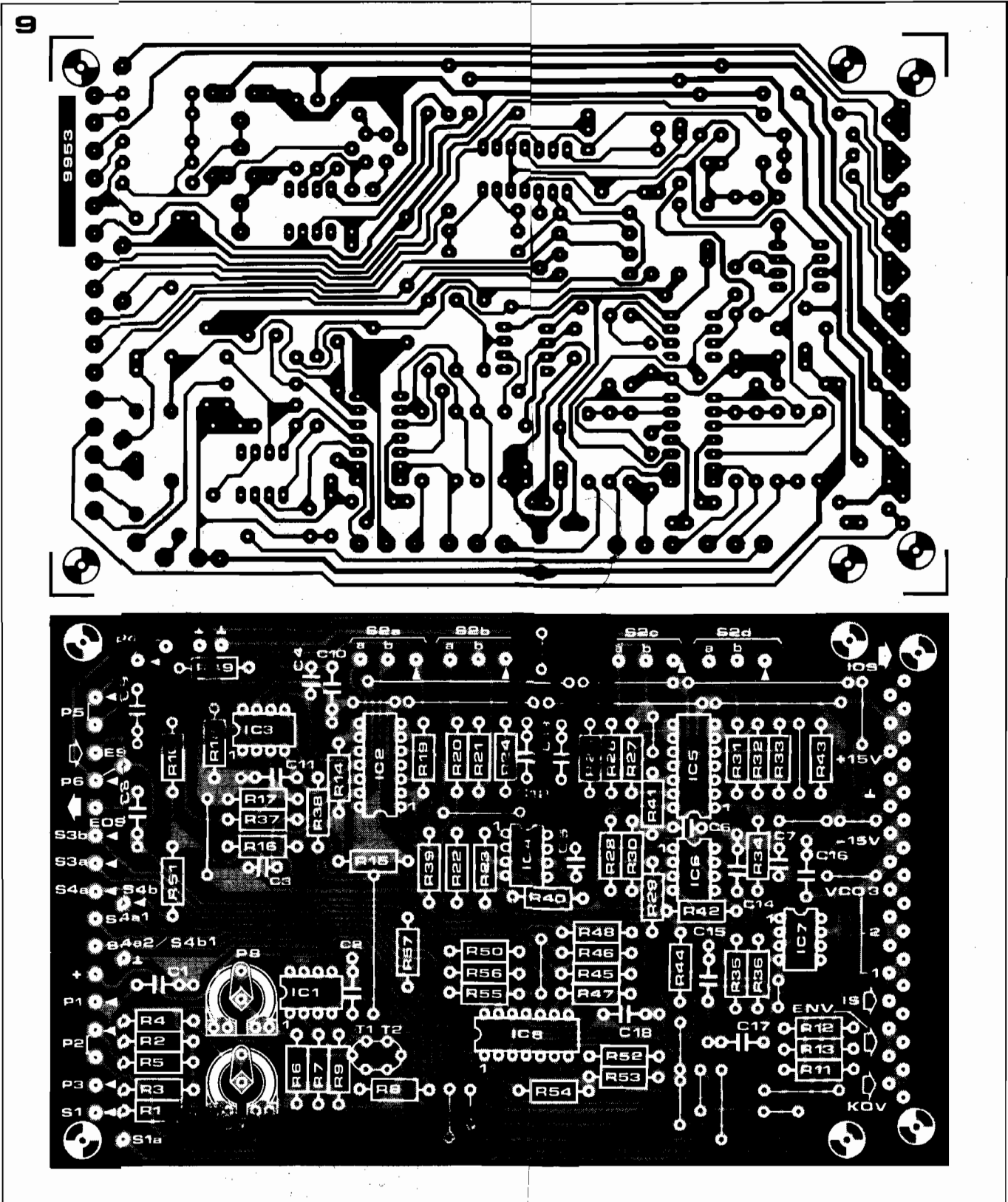

given in figure 9, while a front panel layout is given in figure 10.

10

### Test and adjustment

To enable the exponential converter and the filter section to be tested separately they are joined by a wire link which runs across the board from T2 to a point adjacent to R15. This link should be omitted until the VCF has been tested.

To test the filter section it is necessary to provide a temporary control current. This is done by connecting a 100 k log potentiometer between  $-15\text{ V}$  and ground, with its wiper linked to the junction of R39 and R4 via a multimeter set to the  $100\ \mu\text{A}$  DC range. The test then proceeds as follows:

1. Turn the wiper of P4 fully towards ground, select 24 dB slope with S3 and adjust the control current to  $100\ \mu\text{A}$ .
2. Feed a sinewave signal into the ES socket and adjust either the sinewave amplitude or P5 for 2.5 V peak-to-peak measured on an oscilloscope at the wiper of P5.
3. Monitor the filter output on the 'scope and check the operation of the filter by varying the sinewave frequency and checking that the signal is attenuated above the turnover frequency in the lowpass mode and below the turnover frequency in the highpass mode.
4. The function of S3 should now be checked. Set S3 to the 6 dB position and S2 to the LP position. Increase the frequency of the input signal until the output of the filter is 6 dB down on (i.e. 50% of) what it was in the passband where the response was level. Now switch to 12 dB, 18 dB and 24 dB and check that the response is respectively 12, 18 and 24 dB down, i.e. is reduced to 25%, 12.5% and 6.25% of its original value. The exact results of this test will depend upon the matching of the OTAs.
5. Set the Q control, P4, to its maximum value, when the circuit should show no sign of oscillation. If the circuit does oscillate it will be necessary to increase the value R49. If it does not oscillate then the Q range can be increased by decreasing R49, taking care that instability does not occur.
6. Finally, the linearity of the turnover frequency v. control current characteristic should be checked. Adjust the input frequency until the response is a convenient number of dB down (say 6 dB). Double the control current then double the input frequency and the response should still be 6 dB down.
7. To check the exponential converter connect a 27 k resistor in series with a multimeter set to the  $100\ \mu\text{A}$  range between the collector of T2 and the  $-15\text{ V}$  rail. Then follow the test

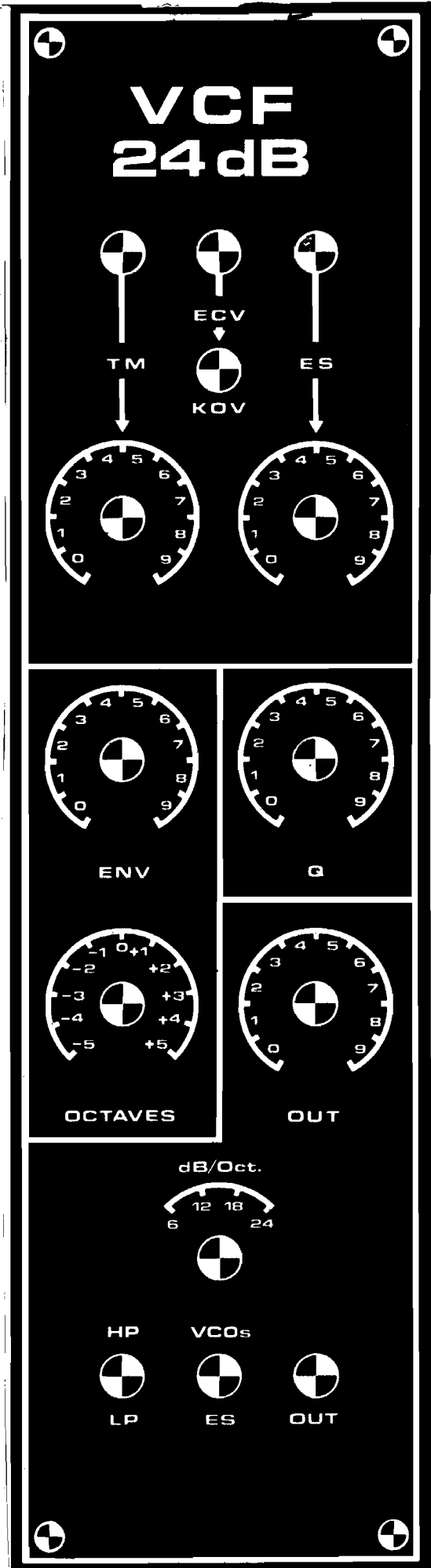

11

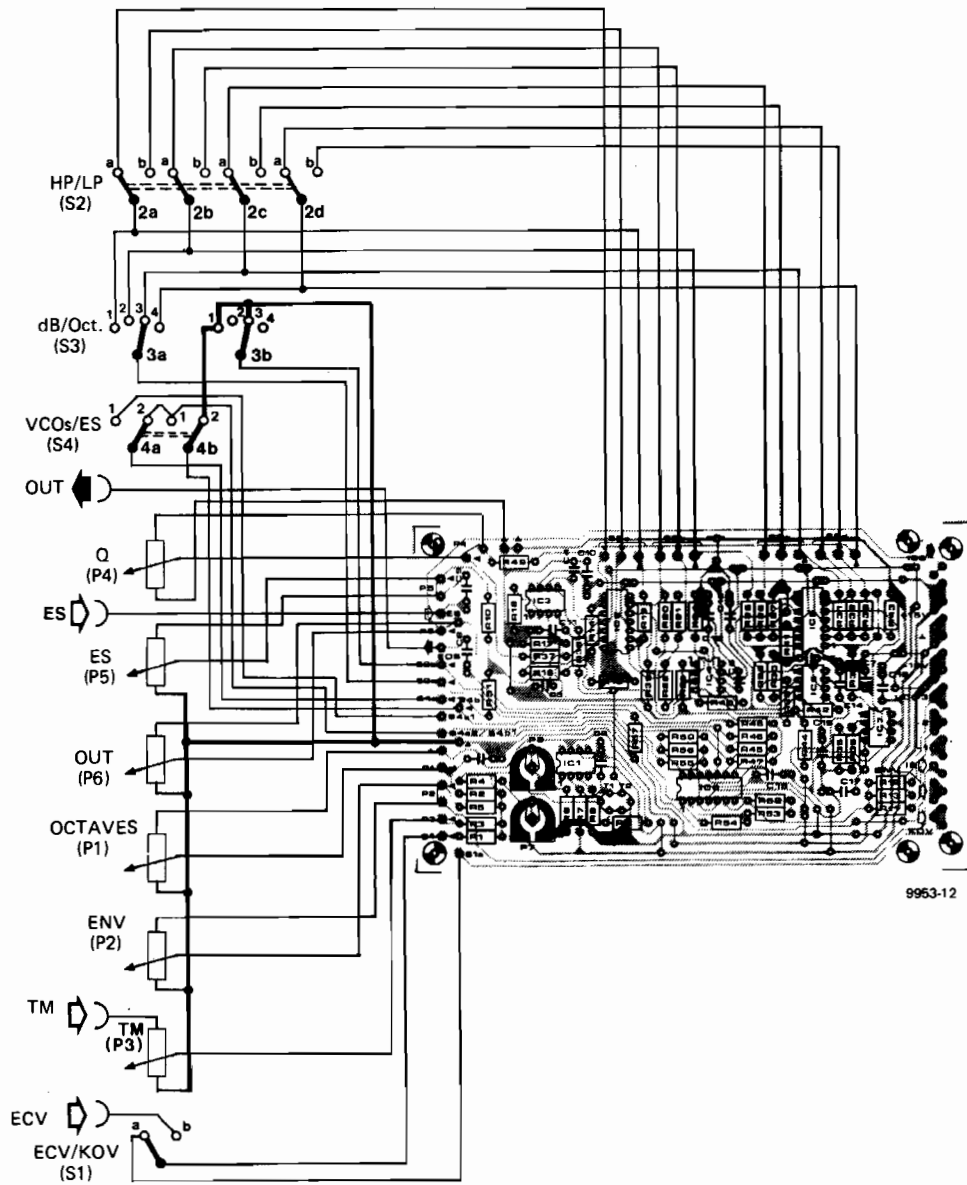
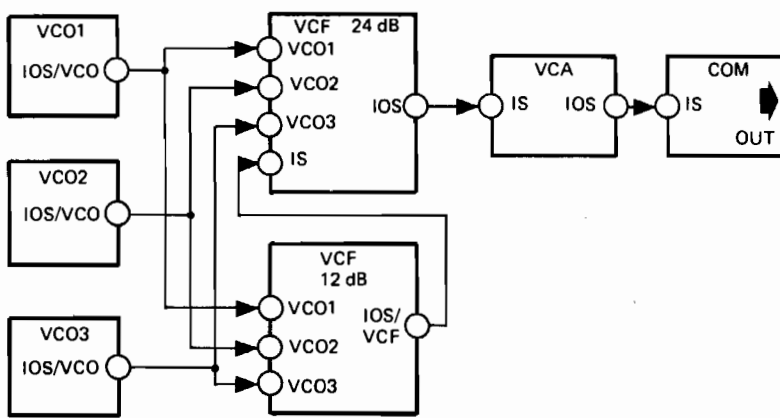

Figure 10. Front panel layout for the VCF. (EPS 9953-2).

Figure 11. Showing the wiring between the p.c. board and the front-panel mounted components.

Figure 12. The 24 dB VCF is connected into the Formant system between the 12 dB VCF and the VCA.

12



9953-13



procedure given in the previous chapter. The offset and octaves per volt adjustments can also be carried out using the procedure given there. During the offset adjustment P4 should be set to minimum and S3 should be set to the 24 dB position. During the octaves/volt adjustment of P8 the Q control, P4, should be set to maximum, as with the 12 dB VCF.

### Using the 24 dB VCF

As can be seen from figure 12, the 24 dB VCF is connected between the 12 dB VCF and the VCA, so that the IOS output of the 12 dB VCF goes to the IC input of the 24 dB VCF instead of to the VCA, whilst the VCA receives its input from the IOS output of the 24 dB VCF. The 24 dB VCF also has inputs from the three VCOs.

In addition to the signal connections the 24 dB VCF must also be provided with supply to the VCF module in accordance with the standard practice for Formant. Provision of control voltage inputs from the ADSR envelope shapers will be discussed later.

For satisfactory operation of the 24 dB VCF the correct setting of the input level is important, even more than in the case of the 12 dB VCF. On the one hand, the input level should not be so large that distortion occurs, but on the other hand it should not be so small that the signal-to-noise ratio is degraded. The 24 dB VCF is designed so that the optimum input level is obtained using three VCOs set to maximum output, with one waveform selected per VCO. If more than three VCOs are in use or more than one output waveform is selected from each VCO then the VCO output levels must be reduced. On the other hand, if only one VCO is used then the signal level may be too low. In

this case it is best to patch the EOS socket of the VCO to the ES input of the VCF, since this input has approximately three times the sensitivity of the hardwired VCO inputs.

The 24 dB VCF is capable of the same basic functions as the 12 dB VCF; driven by the KOV control voltage it will operate as a tracking filter, whilst the ENV and TM inputs allow dynamic modulation of the harmonic content of the VCF output. Due to the greater slope of the 24 dB VCF the setting of the ENV level control is more critical than with the 12 dB VCF, but if correctly adjusted then subtle nuances in the tonal character of the output signal are possible.

The question arises as to which ADSR envelope shaper should be used to control the 24 dB VCF, since only two are built into the basic Formant system, and control the VCA and 12 dB VCF respectively. Because of the modular construction of Formant it is, of course, perfectly feasible to build a third envelope shaper, which is the most versatile arrangement. The alternatives are to patch one of the other ADSR outputs to the TM input of the 24 dB VCF, or to hardwire the ENV input of the 24 dB VCF to the output of the envelope shaper that controls the 12 dB VCF. This latter arrangement is probably preferable, as it allows the ADSR signal to be fed to one or both VCFs by suitable adjustment of their ENV controls and also allows the possibility of patching the output of the other envelope shaper into the TM input of either VCF.

### OTA selection procedure

Although not absolutely essential, it is well worth selecting OTAs with closely matched transconductance characteristics to ensure that the four filter sections track accurately.

A test circuit for the OTAs is given in figure 13. This should be fed with a sinewave signal of about 2 V peak-to-peak (or 0.7 V measured on an AC voltmeter) from a signal generator or from one of the VCOs. The output should be monitored on a 'scope or AC voltmeter. With a control current of 100  $\mu$ A, measured on the multimeter in series with R5, the output voltage should be between 0.7 V and 1.3 V peak-to-peak. Without changing the input level or control current the OTAs to be tested should be plugged into the circuit one at a time and the output level for each OTA noted. The four OTAs whose output levels are most similar should be used in the VCF.

The circuit can also be used to check the linearity of the transconductance v. control current characteristic of the OTAs, e.g. doubling the control current should double the output of the test circuit and halving the control current should halve the output.

Figure 13. Test circuit for the selection of OTAs.

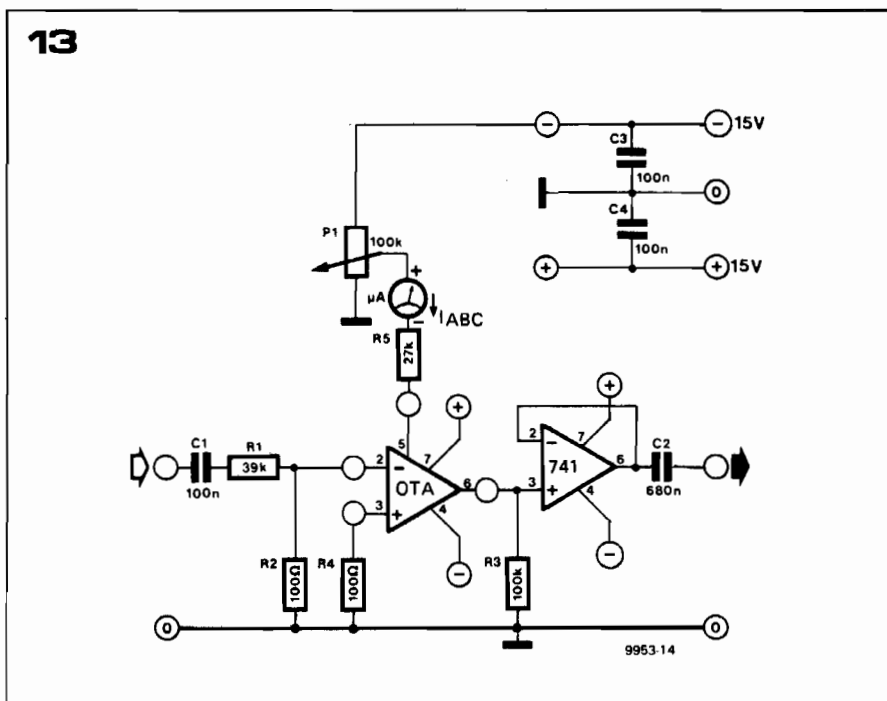

## chapter 8

### resonance filter module

In addition to an almost limitless variety of non-natural, wholly 'electronic' sounds, the Formant music synthesiser can, of course, be used to imitate the voicing of conventional (mechanical) musical instruments. The filter module described in this article is designed to allow more realistic simulation of natural musical instruments by providing the fixed bandpass resonances which are an important determining factor in the timbre of mechanical tone generators.

Although music synthesisers are capable of producing the most 'wired and wonderful' electronic effects, it is a fact that they are frequently employed to imitate the sound of traditional acoustic instruments. Many commercially available synthesisers, for example, are provided with preset facilities for various common instrumental voices, whilst special units such as 'string-synthesisers', which are designed solely to reproduce the sound of a string section, are becoming increasingly popular.

As has already been explained, basic factors influencing the characteristics of a musical note are pitch, dynamic amplitude, and dynamic harmonic content. As the reader will be aware, pitch and dynamic amplitude characteristics are controlled by the VCO (Voltage Controlled Oscillator) and VCA + ADSR (Voltage Controlled Amplifier and Attack - Decay - Sustain - Release) modules in the Formant synthesiser, whilst the VCF (Voltage Controlled Filter) is used to vary the harmonic content of the signal.

However, in the case of mechanical tone generators, for example brass and woodwind instruments, an additional consideration is the existence of resonant areas in the instrument which possess free vibration periods of their own. These resonances, which are known as *formants* (whence the name for the Elektor music synthesiser!) are determined by the shape and mechanical construction of the particular instrument (the wooden back and belly of a violin, the pipes of an organ etc.). Unlike the variable pitch of, say, a violin string, they tend to reinforce the same harmonics, whatever the pitch of the note being played. The nature of the formants in an instrument is in fact one of the factors which govern its quality. It should thus be apparent that, in order

to realistically simulate the tonal characteristics of traditional instruments, one must be able to tailor the static harmonic content of the note accordingly. What is required is a number of resonant filters with independently variable centre frequency, gain and Q-factor. These features are present already in the state variable VCF of the Formant; however, that is only one filter, and more to the point, in this particular application there is no need for the filters to be voltage-controlled, since the filter parameters will be preset to suit whatever musical instrument is being imitated. This explains the reason for the separate manually-controlled resonance filter module described in this article.

**The uses of resonance filters**

The effect of resonance filters can best be heard on 'bright' sharp VCO waveforms which have a high proportion of fairly intense upper harmonics. The effect on vocal sounds can be illustrated by taking a suitable signal with a frequency of around 200 Hz, setting the Q of the filter to a mid-value, and varying the centre frequency from minimum to maximum. At first 'dark' sounding tones, largely devoid of higher harmonics will be obtained; as the centre frequency is increased however, one by one the various vowel sounds can be distinguished until, at high centre frequencies, reedy flute-like sounds are produced. The higher the Q of the filter, the more pronounced the above effects - and vice versa.

All bandpass resonances of musical importance lie between roughly 100 and 2000 Hz. Table 1 lists the main fixed resonances of a number of common musical instruments and also indicates which VCO waveform is best suited to imitate the instrument in question. This table is, of course, merely intended as a rough guide, in the final instance the decision should rest with one's own ears. Unless otherwise indicated, the Q-control should be set to the mid-position. As a further aid, figure 1 shows the fundamental frequency ranges of vari-

Figure 1. The fundamental frequency range of a number of traditional musical instruments, with reference to that of a grand piano. (From: 'Elektronik Taschenbuch, Band 1', Ferd. Dummlers Verlag, Bonn; with kind permission from the publishers.)

1

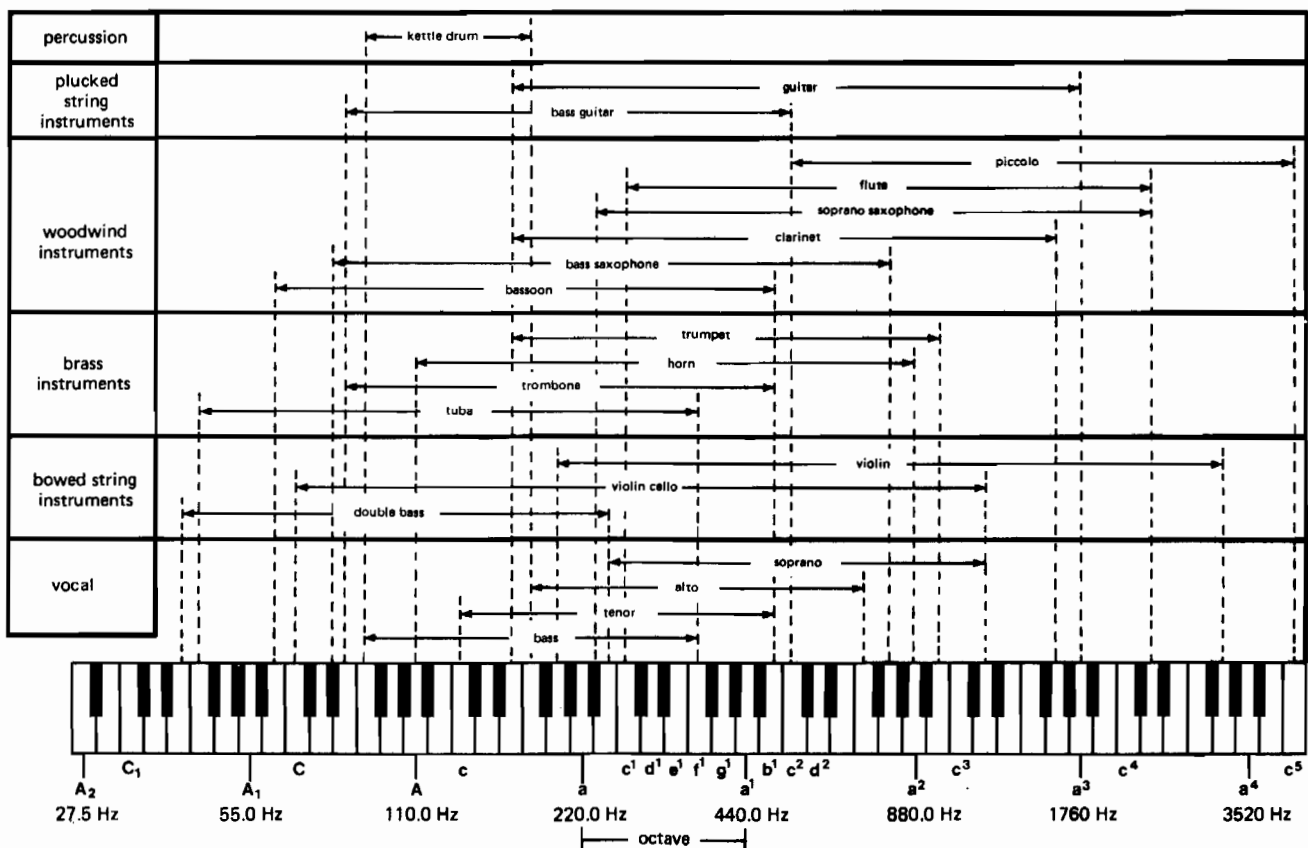

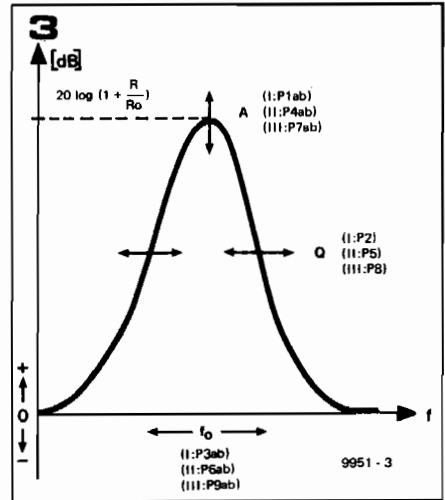
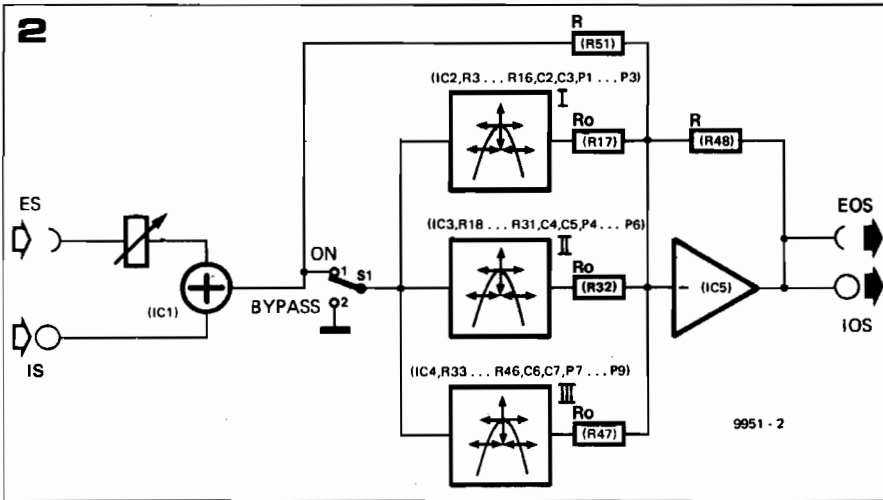

Figure 2. Block diagram of the resonant filter module. As can be seen, it possesses three independently variable filter sections.

Figure 3. The frequency response of one of the three filter sections contained in the resonant filter module. The figure illustrates how the filter parameters can be independently varied by means of the control potentiometers.

Figure 4. Detailed circuit diagram of the filter module.

Figure 5. Track pattern and component layout of the filter module p.c.b. (EPS 9951-1).

instrument	main resonance at	VCO signal
flute	approx. 800 Hz	fairly asym. squarewave
clarinet	1 ... 2 kHz*	sym. squarewave
oboe	1300 ... 1700 Hz*	heavily asym. squarewave (pulse)
bassoon	approx. 440 Hz*	heavily asym. squarewave (pulse)
trumpet	approx. 1500 Hz	'spaced' sawtooth
bugle	approx. 1000 Hz*	sawtooth
trombone	approx. 600 Hz	'spaced' sawtooth
French horn	approx. 400 Hz*	sawtooth
tuba	approx. 250 Hz	sawtooth
violin	approx. 4000 Hz**	'spaced' sawtooth,
cello	approx. 200 Hz**	sawtooth or heavily asym.
double bass	approx. 100 Hz**	squarewave (pulse)

NB:  
 \* with increased Q  
 \*\* if possible, use several resonant filters (or a comb filter)

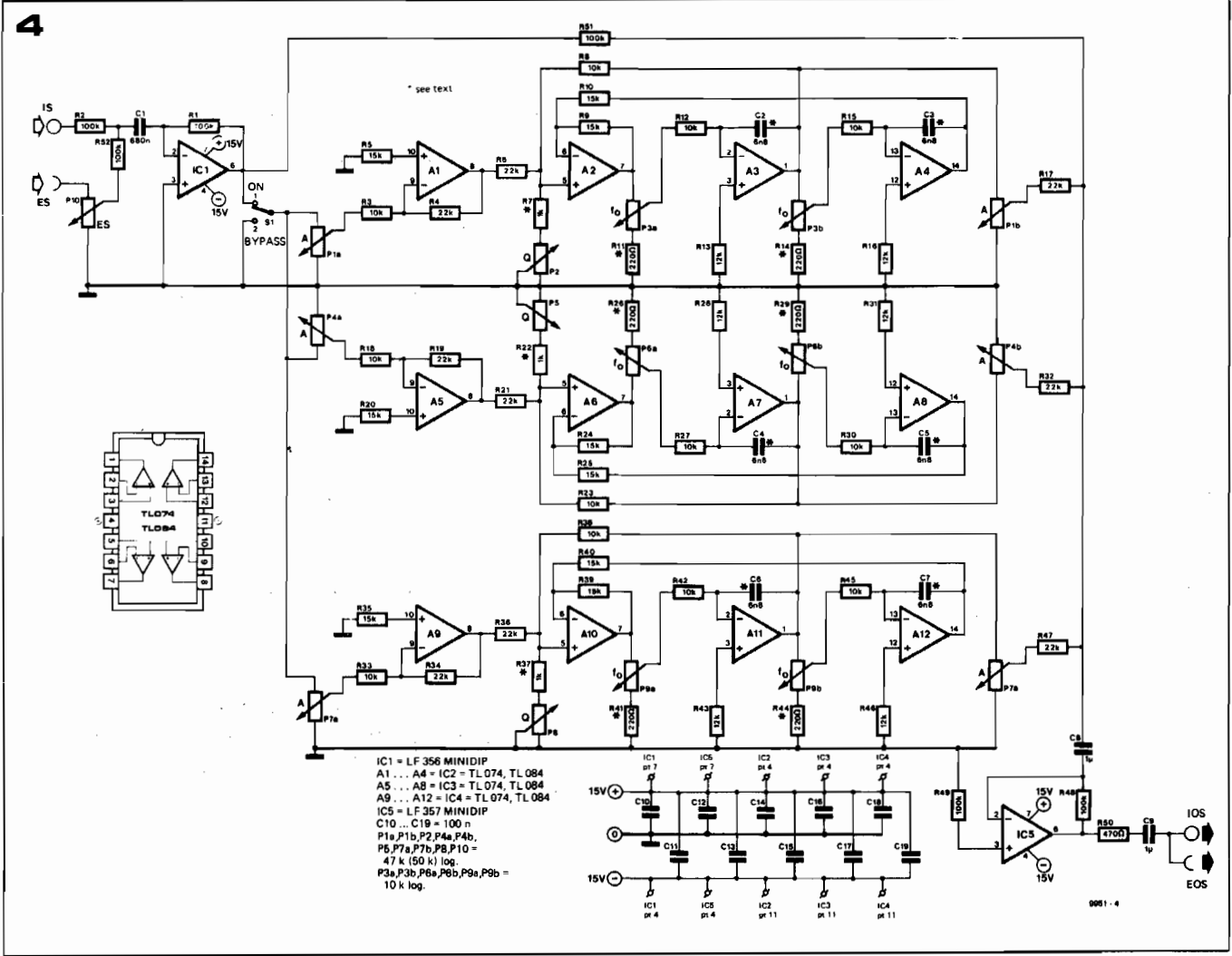

5

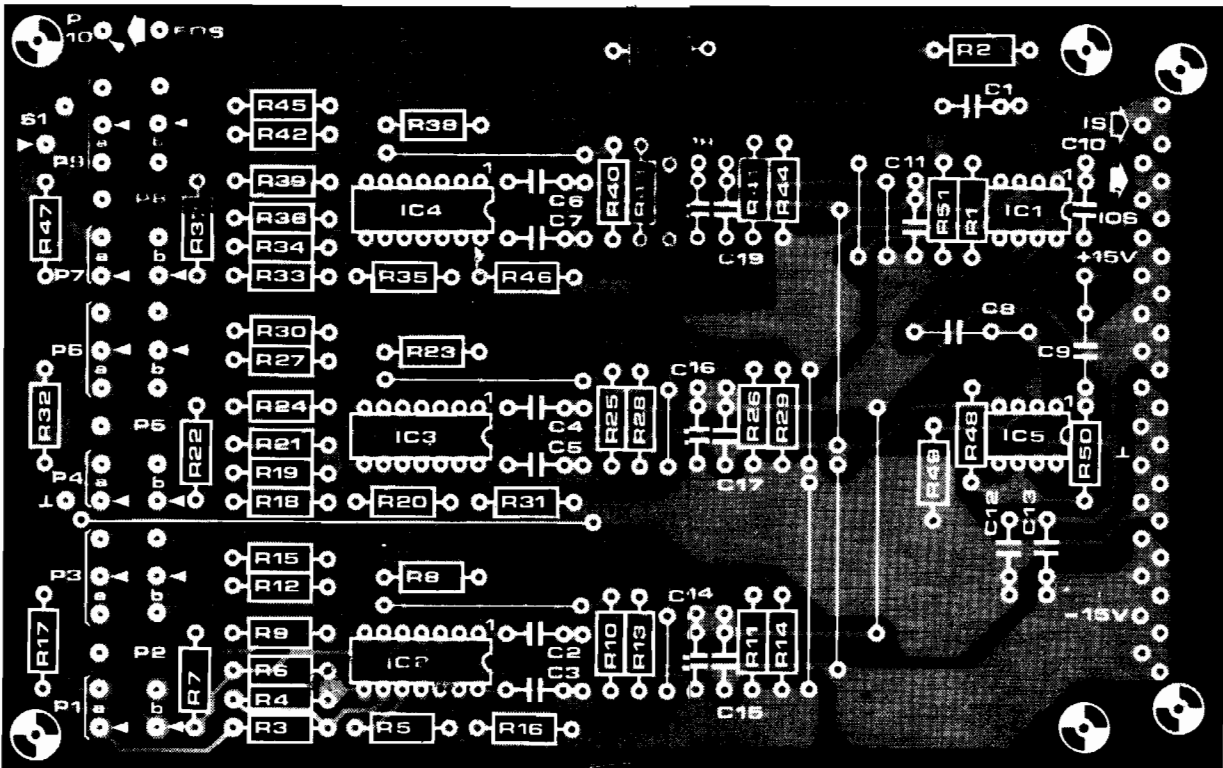
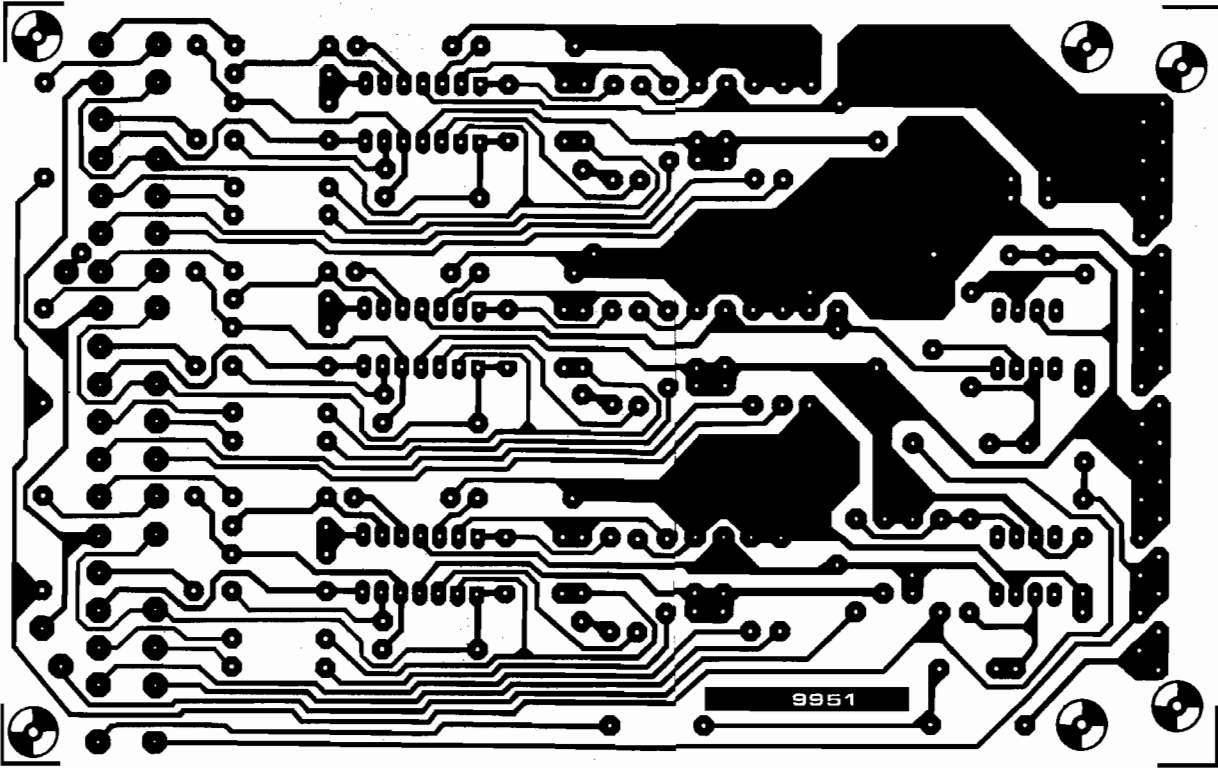

**Parts list to figure 4 and 5.****Resistors:**

R1, R2, R48, R49, R51, R52 = 100 k  
 R3, R8, R12, R15, R18, R23,  
 R27, R30, R38, R42, R45 = 10 k  
 R4, R6, R17, R19, R21,  
 R32, R34, R36, R47 = 22 k  
 R5, R9, R10, R20, R24,  
 R25, R35, R39, R40 = 15 k  
 R7, R22, R37 = 1 k (see text)  
 R11, R14, R26, R29,  
 R41, R44 = 220  $\Omega$  (see text)  
 R13, R16, R28, R31, R43, R46 = 12 k  
 R50 = 470  $\Omega$

**Potentiometers:**

P1, P4, P7 = 47 k (50 k) logarithmic,  
 stereo, dia 4 mm  
 P2, P5, P8, P10 = 47 k (50 k) logarithmic;  
 dia 4 mm  
 P3, P6, P9 = 10 k logarithmic,  
 stereo; dia 4 mm

**Capacitors (all Siemens MKM, MKH or other polycarbonate/polyester type)**

C1 = 680 n  
 C2, C3, C4, C5, C6, C7 = 6n8 (see text)  
 C8, C9 = 1  $\mu$   
 C10 . . . C19 = 100 n

**Semiconductors:**

IC1 = LF 356 (National Semiconductors),  
 Mini DIP  
 IC2, IC3, IC4 = TL 084, TL 074  
 (Texas Instruments)  
 IC5 = LF 357 (National Semiconductors)  
 Mini DIP

**Miscellaneous:**

31-way DIN 41617 edge connector or  
 terminal pins  
 S1 = miniature SPDT  
 2 miniature sockets 3.5 mm dia.  
 10 x 10 mm collet knobs (with pointer)  
 1 front panel

ous traditional instruments, with refer-  
 ence to a piano keyboard.

**Circuit**

The basic requirements of the filter circuit are, independently variable centre frequency, Q and gain. Since the function of the filter is essentially to enhance a particular band of frequencies (corresponding to the formants of the instrument in question), the circuit is of the boost-only type, i.e. provides selective gain. Without the need to provide a selective cut (below the 0 dB line) the circuit design is considerably simplified.

A total of three resonant filters forms an acceptable compromise between the number of settings required for reasonably realistic imitation and the constraints of space and economy. Of course, it is quite possible to double the range of control facilities by connecting a second filter module in cascade with the first.

**Block diagram**

The block diagram of the resonant filter module is shown in figure 2. The figures

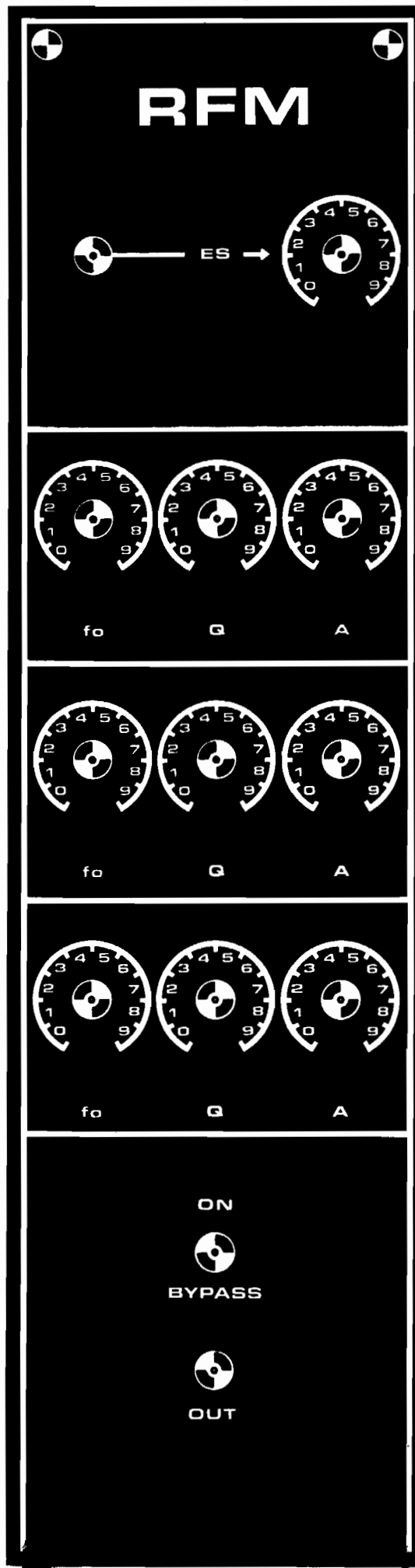

in brackets indicate which components in the final circuit are associated with the different sections of the circuit. Signals can be fed in via the panel-mounted socket (ES) or via the hard-wired input (IS). A portion of the signal is fed direct to the output summing amplifier via R (R51 in the complete circuit) and the input signal is also fed to three bandpass filters whose gain, centre-frequency and Q can all be varied. The outputs of these filters are also summed in IC5 via resistors  $R_O$ . The output of the filter module will thus consist of a portion of the original input signal plus signals boosted around the centre frequencies of the three filter stages. Two outputs are provided from the filter module, an internal hardwired output (IOS) and an output to a front panel socket (EOS). A bypass switch is provided, which allows the three filter sections to be switched out, in which case only the original signal appears at the output, and the gain is frequency independent, being unity.

The amount of boost that can be provided by a filter section relative to the gain obtained in the 'bypass' condition is determined by the gain of the filter sections and the ratio  $R/R_O$ . If it is assumed that the filter gain can be varied between zero and one then the maximum amount of boost (in dB) is  $20 \log(1 + \frac{R}{R_O})$ .

The frequency response of a filter section is shown in figure 3. The figures in parentheses indicate which controls in the complete circuit vary the different parameters of the filter.

The complete circuit of the filter module is shown in figure 4. IC1 sums and inverts the two input signals, whilst the three filter sections are of the state-variable type. The resonant gain of the filters is set by means of P1, P4 and P7 respectively. One gang of the pots is connected at the input, the other at the output of the filter. This has the effect of improving the dynamic range, since it means reduced noise and less chance of overloading. Finally, there is the inverting summing amplifier round IC5, which also cancels the phase shift introduced by IC1.

With the values for R and  $R_O$  given in the circuit diagram, the maximum gain of the filter is approx. +15 dB. The quality factor, Q, can be varied by P2 (P5, P8) between roughly 0.8 and 5. The centre frequency can be varied between approx. 50 and 2300 Hz, which is more than sufficient for normal use. The frequency range can, however, be modified by altering the value of a number of components; the necessary changes are detailed in the appendix.

Maximum Q is obtained for the minimum resistance of the Q-potentiometer. The maximum Q can therefore be increased by reducing the value of R7 (R22, R37); in this way a Q of between 20 and 30 can easily be obtained. A high Q is useful when processing waveforms such as squarewaves, which have

7

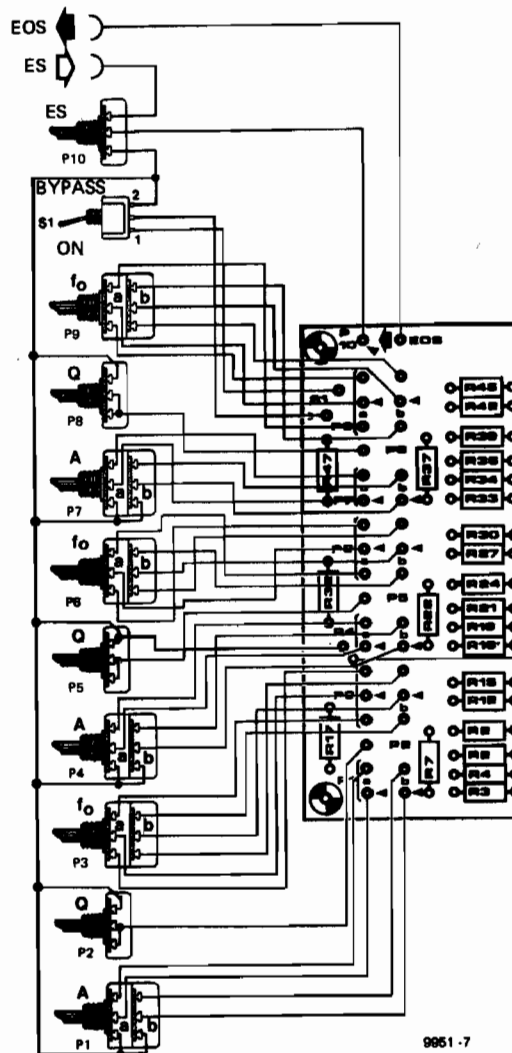

Figure 6. Because of the large number of controls, the front-panel for the resonant filter module is clearly different from the other Formant front-panels (EPS 9951-2).

Figure 7. Wiring diagram for the components mounted on the front-panel.

very steep edges. These tend to set the filters 'ringing' at their resonant frequencies, and produce percussive effects. For  $R7 (R22, R37) = 470 \Omega$ , a Q of 11.3 is obtained;  $R7 = 330 \Omega$  gives a Q of 15.8, and  $R7 = 220 \Omega$  a Q of 23.4. The higher the Q, the more pronounced the percussive effect.

### Construction

The printed circuit board for the resonant filter module is shown in figure 5.

As far as the selection of components is concerned, the usual criteria apply. The only difference is that in view of the large number of front-panel controls (10 potentiometers) it is strongly recommended that miniature components (miniature pots with 4 mm diameter spindles) be used. In this way the controls can be arranged in functional groups of three to a row.

The front panel for the filter module is shown in figure 6, and the details of the wiring for the front-panel controls are illustrated in figure 7. In contrast to the

other Formant modules, the resonant filter module requires no calibration or adjustment procedure. The operation of the circuit can be checked by feeding in a white noise input from the noise module. Varying the three filter parameters should produce clearly audible changes in the resulting sound. It will also be apparent that rapid variation of the Q- and  $f_0$  controls produces effects similar to phasing, thus the filter module can be used to provide manual phasing.

The scale on each of the  $f_0$  potentiometers on the front panel is calibrated with five nominal frequencies. The three middle settings in particular should be viewed as rough guidelines, since the resistance curve of logarithmic potentiometers can exhibit fairly wide tolerances.

The filter module should be placed between the COM-module and the power amp. However, if one wishes to use the headphone output on the COM-module, the resonant filter module can be connected directly before the latter.

## Appendix

With the component values given in the circuit diagram, the centre frequency of the filters can be varied between roughly 50 and 2300 Hz. To calculate the correct values for higher frequencies than this, the procedure is as follows:

Firstly, the desired maximum frequency of  $f_0$  can be used to calculate the value of  $C_2 = C_3 = C_4 = C_5 = C_6 = C_7 = C$  from the following equation:

$$C = \frac{16}{f_0 \text{ max}}$$

where C is in nanofarads and  $f_0$  in kHz. Secondly the value of resistor R (see figure 2) can be determined on the basis of the desired minimum centre frequency  $f_0$  min:

$$R = \frac{16}{C \cdot f_0 \text{ min}}$$

where C is in nanofarads, R is in k $\Omega$ , and  $f_0$  in kHz

The value of  $R_0 = R_{11} = R_{14} = R_{26} = R_{29} = R_{41} = R_{44}$  can be calculated from:

$$R_0 = \frac{10}{R - 2}$$

where R and  $R_0$  are in k $\Omega$ . These equations can be used to check the values of figure 4.

## chapter 9

### ADSR

**The ADSR (Attack-Decay-Sustain-Release) shaper is used to control the VCF and VCA modules and thereby determine the dynamic harmonic structure and dynamic amplitude characteristic of the VCO signals.**

It is often not realised, even by musicians, how much the character of an instrument is determined by the dynamic amplitude and harmonic behaviour, rather than by the steady-state harmonic content of the instrument. If the attack and decay periods of a note are artificially modified, then the whole character of the sound is altered. An interesting and amusing experiment is to record the sounds of several musical instruments, but to remove the attack and decay periods by bringing up the recording level after the note starts and fading it down before the note ends. Then ask some musical friends to identify the instruments. They will no doubt be amazed how characterless the sound of an instrument becomes when robbed of its particular amplitude envelope.

On the other hand, starting with a single basic waveform such as the triangle output of the Formant VCO, a whole range of instrument sounds can be produced simply by varying the amplitude envelope, ranging from 'soft' sounds such as flute and some organ voices, to 'hard', percussive sounds such as piano and xylophone.

Envelope control of the harmonic content using the VCF allows even greater variation in the character of the sound.

### Types of envelope curves

The envelope shaper of the synthesiser must be able to simulate the envelope contour of conventional musical instruments when the synthesiser is used in an imitative capacity, and also to produce envelopes that are purely synthetic in character (i.e. not found in sounds produced by normal acoustic methods). Fortunately, there are relatively few types of envelope contour that are musically important, and these are all fairly easy to generate electronically.

#### 1. Attack/decay contour

The simplest type of envelope curve is that consisting only of attack and decay periods. The envelope contour rises to a peak when the note is played, and begins to decay immediately the peak is

passed (see figure 1). By varying the attack and decay times a wide variety of sounds can be produced.

For example, if a rapid attack and slow decay is applied to the VCA control, then a percussive sound like a piano results. Applied to the VCF in the low-pass mode, the same envelope contour can produce very bright, metallic sounds, depending on the input waveform.

If the attack period is made long and the decay period short, then applying this to the VCA will produce completely synthetic 'fantasy' sounds similar to those obtained by playing a recording backwards. Applying this type of envelope contour to the VCF can produce sounds similar to those of a brass instrument played staccato.

However, the main use of this type of envelope curve is for the production of percussive sounds such as xylophone, marimba, glockenspiel, bells and gongs, cymbals, and struck or plucked strings such as guitar, banjo, harp, other string instruments played pizzicato, harpsichord, and of course, piano.

#### 2. Attack-sustain-release contour

The attack/decay characteristic previously described is typical of instruments where the sound is initiated by a short pulse of energy (e.g. by striking or plucking a string), after which the sound dies away since there is no further excitation to sustain it. The envelope contour shown in figure 2 is typical of instruments in which a note is sounded and sustained, such as a pipe organ, woodwind instruments, and bowed string instruments. In a pipe organ the note builds up fairly rapidly after a key is depressed as standing wave modes are established in the pipe, and the note is sustained by virtue of the fact that air is continuously blown into the pipe. When the supply of air stops on releasing the key the note terminates more or less rapidly.

The same basic contour applies to woodwind instruments and to string instruments played with a bow, since the note is here again sustained by blowing or bowing. However, with such instruments much greater expression can be obtained by modulation of the





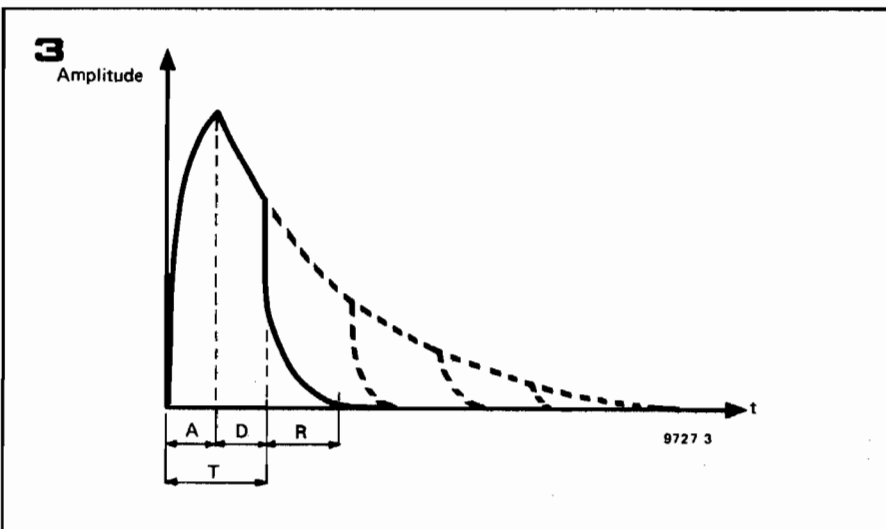
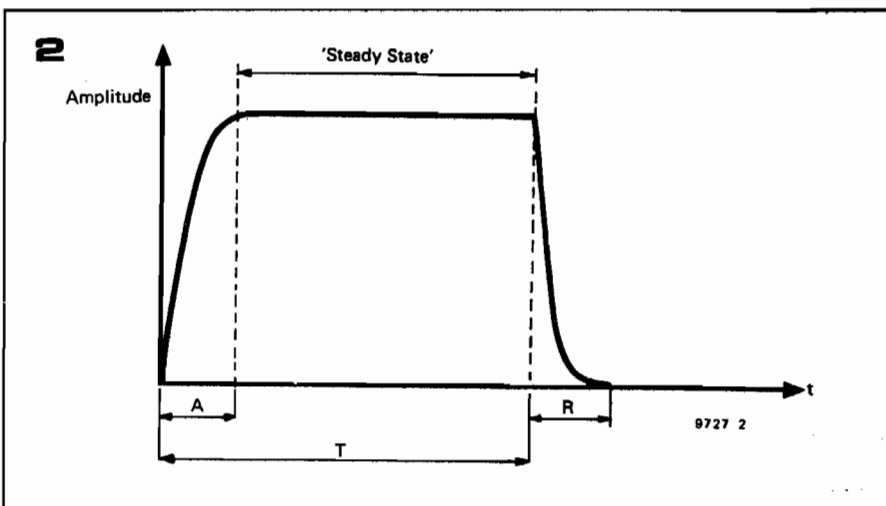
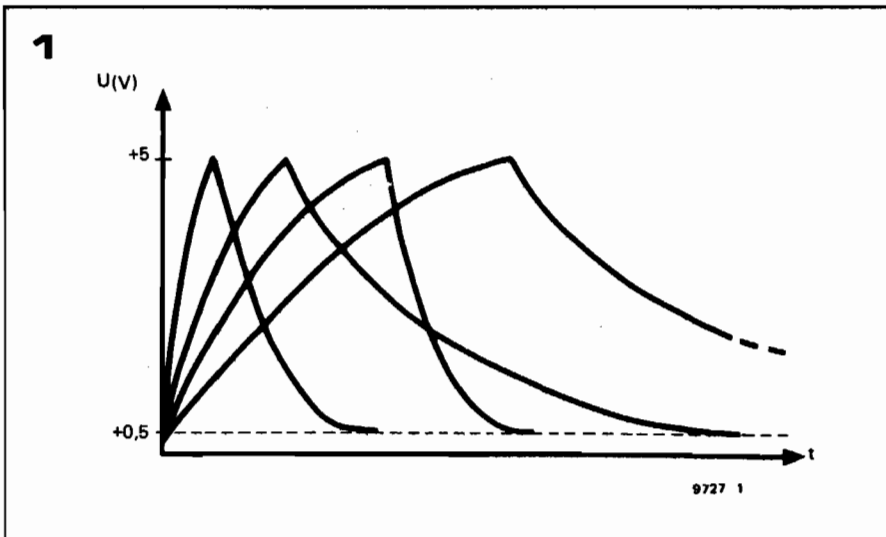

steady-state level, since this is determined by the player, and not by a mechanical blower as is the case with a pipe organ.

With a synthesiser, a degree of expression can be obtained by modulating the VCA using the low-frequency oscillators or noise source.

### 3. Attack-decay-release contour

A variation on the attack-decay contour is shown in figure 3. Here the slow

Figure 1. The attack-decay envelope contour is the simplest contour found in music.

Figure 2. The attack-sustain-release contour is used to simulate instruments where the note can be sustained at a constant level, such as organ, woodwind, and bowed string instruments.

Figure 3. Instruments such as the piano can be simulated using the attack-decay-release contour. As long as the key remains depressed the decay path is followed, but once the key is released the note is ended more abruptly, following the release contour.

decay is allowed to continue for only a certain time, and the note is then terminated by a more rapid release. The most common example of this type of contour is provided by our old friend, the piano. When a note is sounded and the key remains depressed, then the damper is held off the string and the note decays over a period of a few seconds. If, however, the key is released after playing a note, the felt damper contacts the string and the note terminates after about 500 ms.

### 4. Attack-decay-sustain-release contour

Most of the examples given so far relate to envelope control of the VCA, since the amplitude contour of a sound is somewhat easier to visualise than its dynamic tone colour behaviour. However, the most complex envelope contour, shown in figure 4, is a good illustration of envelope control of the VCF.

Many brass instruments, such as the trumpet, are characterised by a rapid build-up of harmonics during the attack period of the note, which gives the instrument a very strident sound. Once the note is established, however, the harmonics die away somewhat, and the tone is much more mellow during the steady state period. Finally, during the release period at the end of the note, the note dies away fairly rapidly.

This type of characteristic can be obtained by using the VCF in the low-pass mode and controlling it with an envelope contour similar to that shown in figure 4. As the control voltage rises during the attack period, so the turn-over frequency of the VCF increases, passing more harmonics. During the decay period the VCF turnover frequency falls until the steady-state value is reached, and finally, during the release period the VCF turnover frequency drops very rapidly.

### Envelope shaper requirements

It is apparent from figure 5 that the envelope contours shown in figures 1 to 3 are merely special cases of the more general attack-decay-sustain-release contour illustrated in figure 4. Any of the four contours can be generated by an envelope shaper having the following four functions:

- variable attack time (A)
- variable decay time (D)
- variable sustain level (S)
- variable release time (R)

These four parameters can be preset manually using the ADSR controls of the envelope shaper. The envelope shaper is controlled by the gate pulse output of the keyboard. When a key is depressed the gate output goes high and this initiates the attack-decay sequence. The output of the envelope shaper then remains at the sustain level until the key is released, when the release period begins.

4

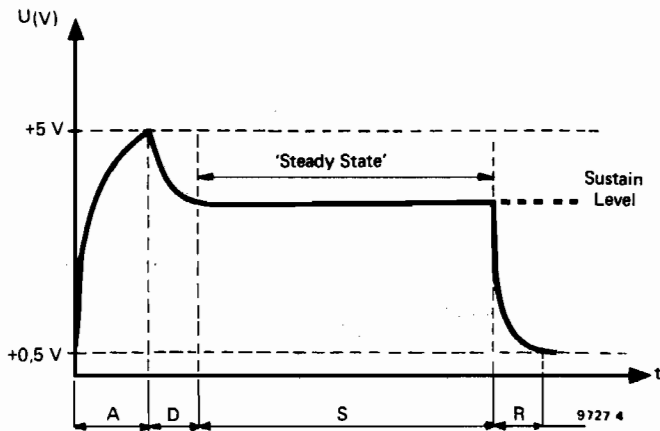

**Block diagram**

The required exponential attack, decay and release characteristics are easily obtained by charging and discharging a capacitor through resistors, and the sustain level by clamping the capacitor voltage to a preset D.C. level during the sustain period. The basic principle of the envelope shaper is illustrated in figure 6. The gate pulse is fed to a voltage follower A1, and when the gate pulse is high C charges exponentially through P2 and D2 (and T3).

At the end of the Attack period, 'switch' T3 is opened and T6 is closed. Capacitor C now discharges through D4 and P3 (Decay), until the Sustain level is reached. This level is maintained until the gate pulse finishes, either when the key is released or when a preset time has elapsed.

When the gate pulse finishes, the output of A1 goes to zero volts, and C discharges through D1 and P1 (Release). The capacitor cannot discharge fully,

5

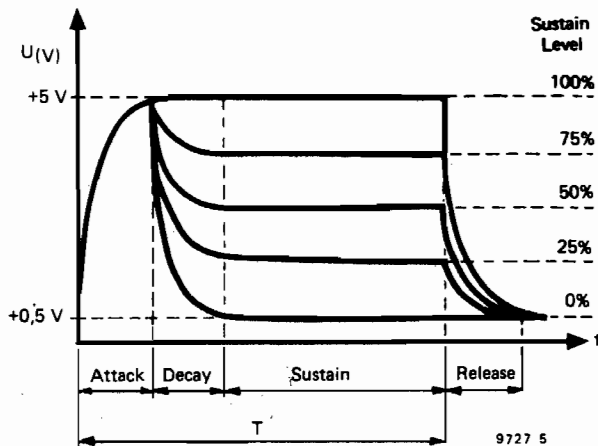

**ADSR adjustment ranges:**

Attack period (A)	10 ms ... 20 s
Decay period (D)	10 ms ... 20 s
Sustain level (S)	0.5 V ... 5 V
Release period (R)	10 ms ... 20 s

6

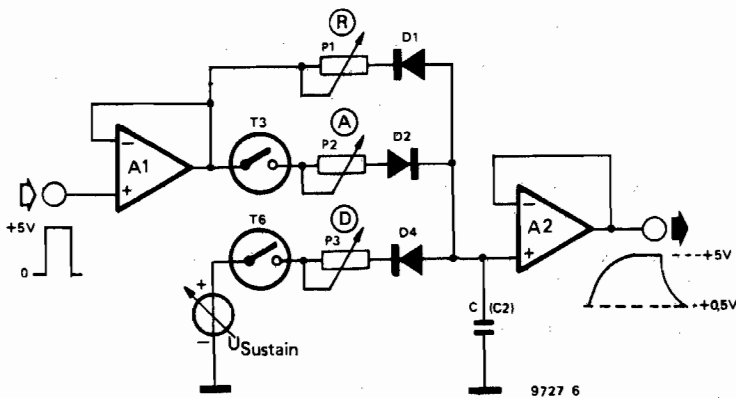

since D1 ceases to conduct once the voltage on C has fallen to about 0.5 V, but this is not important as it merely constitutes a D.C. offset which can be compensated for. The attack, decay and release times may be adjusted by means of P2, P3 and P1.

**Complete circuit**

The complete circuit, which is shown in figure 7, is, of course, more complicated. The envelope shaper has two modes of operation, ADSR and AD, which are selected by means of S1. With S1 in position 'b' (ADSR) the circuit operates as follows:

When a key is depressed the gate pulse output goes to +5 V. IC1 has a gain slightly greater than unity, so about +6 V appears at its output.

The leading edge of the gate pulse also triggers monostable T1/T2, which pro-

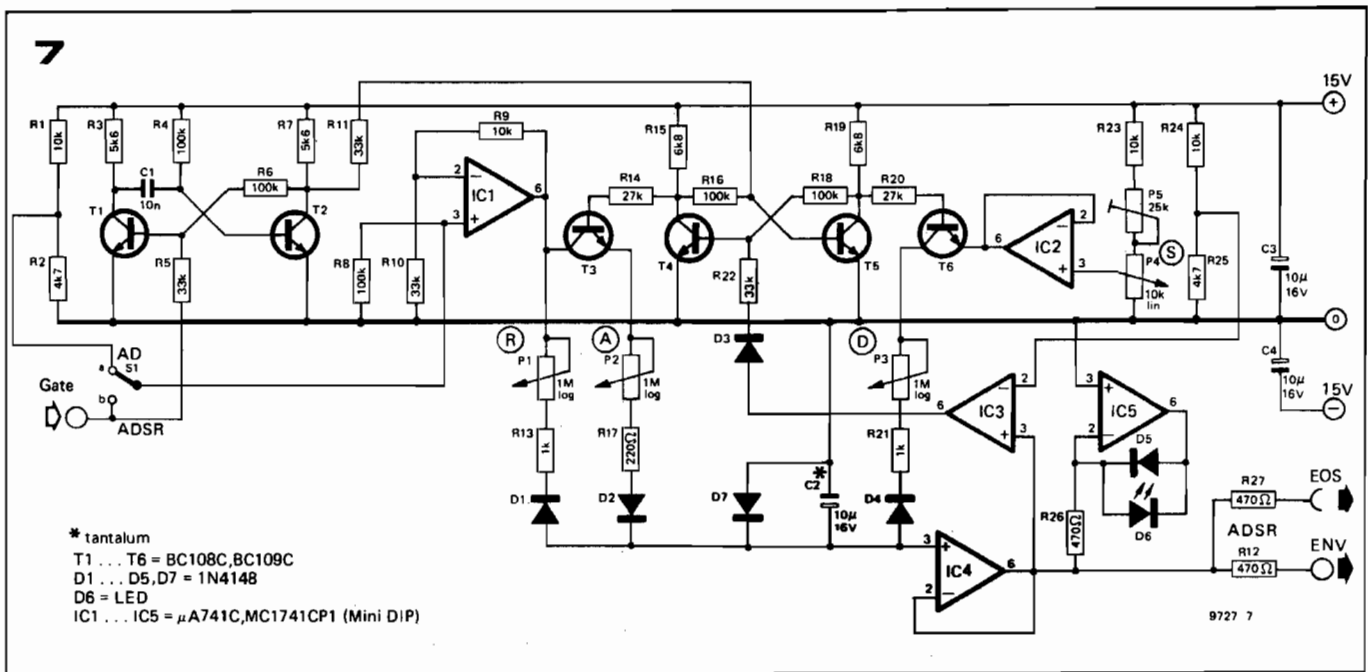

duces a short pulse to set flip-flop T4/T5 (T5 turned on and T4 turned off). The collector voltage of T4 thus rises, turning on T3 and allowing C2 to charge from the output of IC1 through T3, P2, R17 and D2. This is the attack period.

The voltage on C2 is fed to voltage-follower buffer IC4, which is connected to the outputs EOS and ENV and also to the non-inverting input of IC3. This IC functions as a comparator, with its inverting input held at about 4.7 V by R24 and R25. When the voltage on C2, and hence at the output of IC4, exceeds this value, the output of IC3 swings positive, resetting flip-flop T4/T5, turning off T3 and terminating the attack period. T6 is turned on, initiating the decay period when C2 discharges through D4, R21, P3 and T6 into the output of IC2 until the sustain level, set at the output of voltage follower IC2 by P4, is reached.

The output of the envelope shaper then remains at the sustain level until the key is released, when the output of IC1 goes to zero volts and C2 discharges through D1, R13 and P1 (release period). Diode D7 protects C2 in the event of the output of IC1 going negative for any reason, when the voltage across C2 is clamped to a maximum of  $-0.7$  V.

A LED indicator constructed around IC5 allows visual monitoring of the envelope contour. The brightness of the LED follows the envelope voltage. Two outputs are provided from the envelope shaper; an external output to a front panel socket (EOS), and an internally wired output (ENV). The full ADSR envelope contour is, of course, produced only if the key is depressed for a period longer than the attack plus decay time, and if the sustain level is greater than 0%. If the key is released before the sustain level is reached then the release period is initiated prematurely, and either AR or ADR curves may be produced. If the

Figure 4. The attack-decay-sustain-release contour is the most complex envelope shape provided by the Formant envelope shaper. When applied to the VCF it is useful for imitating brass instruments, where the harmonic content of the note rises initially to a large value, then reduces to a lower level during the steady-state part of the note.

Figure 5. By varying the sustain level the envelope contour can be changed from an AD contour at 0% sustain, through various ADSR contours to an ASR contour at 100% sustain. T is the time for which the key remains depressed.

Figure 6. This simplified diagram illustrates the basic principle of the envelope shaper. C charges through D2 and P2 during the attack period. It then discharges through D4 and P3 to the (adjustable) sustain level; finally, it discharges through D1 and P1 during the release period. P1, P2 and P3 can be used to vary the release, attack and decay times.

Figure 7. Complete circuit of the Formant envelope shaper.

sustain level is 0% then only AD or ADR curves may be produced, depending on when the key is released. If the sustain level is 100% then, of course, only AR or ASR curves may be produced, depending on when the key is released, since the decay period is inhibited.

### Triggered AD mode

It is sometimes useful to be able to produce AD envelope contours that are unaffected by releasing the key, that is to say, once the key is depressed, a fixed attack-decay sequence is initiated, which is completed whether the key is released or not. This triggered AD contour is obtained by setting S1 to position 'a' and selecting 0% sustain level. The input of IC1 is now connected to the junction of R1 and R2, so its output is permanently at about +6 V, irrespective of the gate input.

When a key is depressed, the gate signal triggers the monostable, setting the flip-flop and turning on T3. At the end of the attack period, comparator IC3 resets the flip-flop, turning on T6 and initiating the decay period. C2 will now discharge through D4, R21, P3 and T6 to the 0% level (sustain is set at 0%). Even if the key is released before this sequence is complete, the release period is inhibited since the output of IC1 is permanently at +6 V, so C2 cannot discharge through D1, R13 and P1.

### Construction

There are no special requirements with regard to resistor tolerances in the envelope shaper circuit, and ordinary, good-quality 5% carbon film components are quite adequate; C2 should be a tantalum electrolytic capacitor for low leakage, and C1 the usual

8

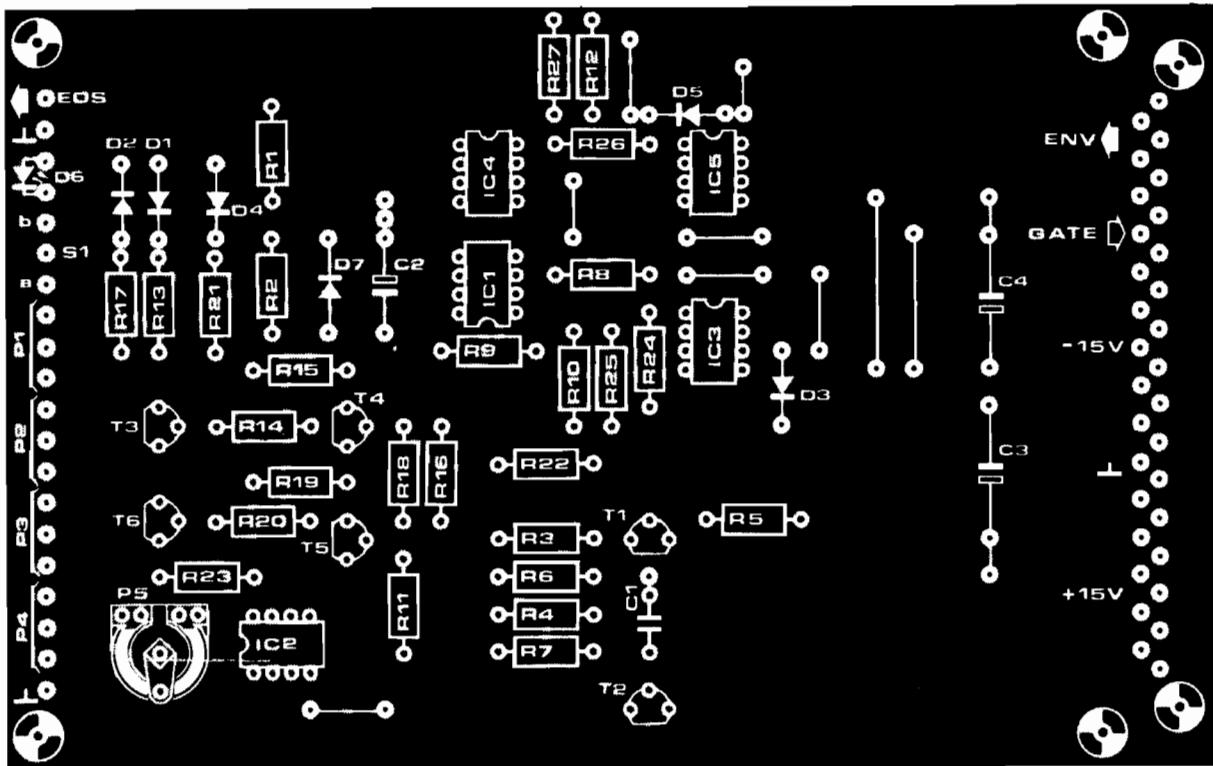
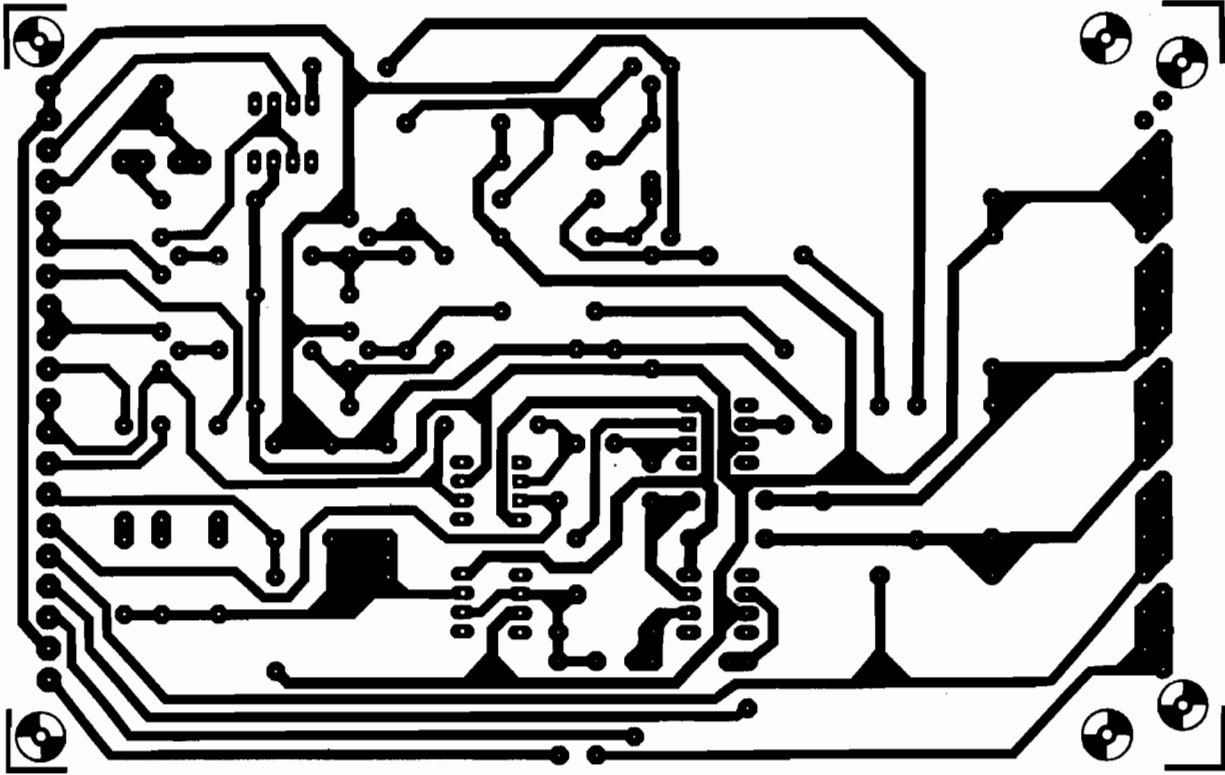

## Parts list for figures 7 and 8

## Resistors:

R1,R9,R23 = 10 k  
 R2,R25 = 4k7  
 R3,R7 = 5k6  
 R4,R6,R8,R16,R18 = 100 k  
 R5,R10,R11,R22 = 33 k  
 R12,R26,R27 = 470  $\Omega$   
 R13,R21 = 1 k  
 R14,R20 = 27 k  
 R15,R19 = 6k8  
 R17 = 220  $\Omega$

## Potentiometers:

P1,P2,P3 = 1 M log.  
 P4 = 10 k lin.  
 P5 = 25 k preset

## Semiconductors:

T1 ... T6 = BC 108C, BC 109C or  
 equivalent  
 D1 ... D5,D7 = 1N4148, 1N914  
 D6 = LED (TIL 209 or similar)  
 IC1 ... IC5 =  $\mu$ A 741C, MC 1741  
 CP1 (MINI DIP)

## Capacitors:

C1 = 10 n  
 C2 = 10  $\mu$ /16 V tantalum  
 C3,C4 = 10  $\mu$ /16 V

## Miscellaneous:

31-way Euro connector  
 (DIN 41617)  
 1 x 3.5 mm jack socket  
 4 x 13 ... 15 mm collet knobs  
 with pointer

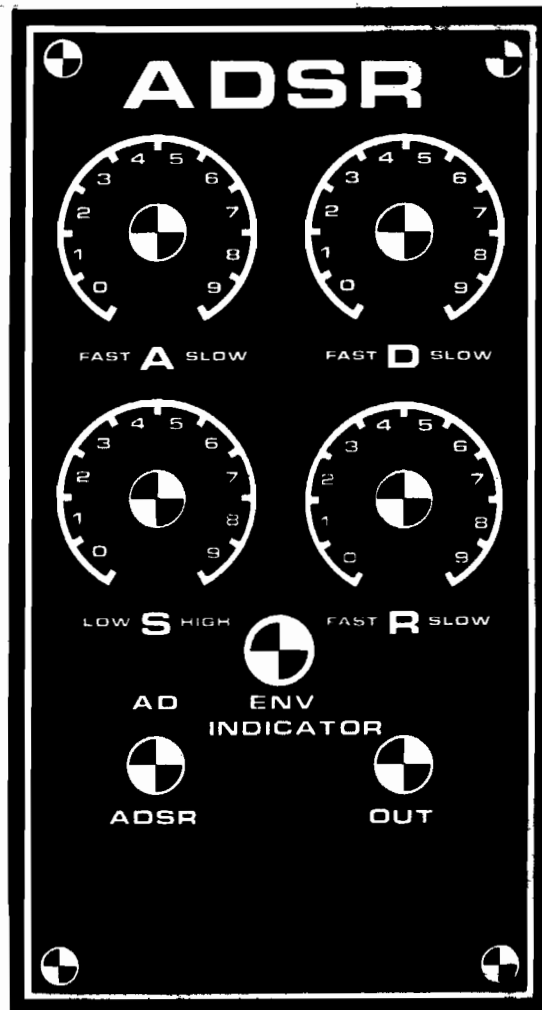

Figure 8. Printed circuit board and component layout for the envelope shaper (EPS 9726-1).

Figure 9. Front panel layout for the envelope shaper module.

polyester or polycarbonate type. It is a good idea to test T3 and T6 for leakage, using the method detailed in chapter 5. A printed circuit board and component layout for the envelope shaper are given in figure 8, and a front panel layout is shown in figure 9. Connections to the front panel are fairly simple, the only front panel-mounted components being the four potentiometers for attack time, decay time, release time and sustain level, switch S1, the external output socket and the envelope indicator LED.

### Testing and adjustment

To test the envelope shaper a gate pulse must be available from the 'GATE' output of the interface receiver board. The EOS output of the envelope shaper is monitored on an oscilloscope with the Y sensitivity set to about 1 V/div and the timebase set to about 10 ms/div.

For the first test, the sustain level is set to zero, S1 is set to the 'AD' position and the attack and decay potentiometers are set to 'fast'. The release potentiometer has no effect during this test. If a key is depressed at short intervals then a short AD envelope curve will be seen, which rises and falls between about 0.5 V and 5 V. The out-

put of IC3 can also be monitored, to check that it swings briefly between -15 V and +15 V when the peak of the attack curve is reached.

The only adjustment required to the envelope shaper is to set the 100% sustain level, using P5, to correspond with the voltage on C2 at the end of the attack period. If it is too low, then there will always be a decay, even at 100% sustain level; if it is too high then the calibration of P4 will be inaccurate, since 100% sustain will be reached before maximum rotation of the potentiometer.

To make the adjustment, the sustain level is set to 100% and medium attack and decay times are selected. Preset P5 is then adjusted until there is just no decay after the attack period (i.e. the attack period blends into the sustain level with no dip). The adjustment can be checked by turning P4 slightly to the left, when a slight dip after the peak of the attack period should be noted. As P4 is turned further anticlockwise then the decay down to the sustain level will become greater and greater, until finally, at 0% sustain level, pure AD curves will be produced. The envelope shaper is now ready for use.

## chapter 10

## voltage controlled amplifier (VCA)

This chapter continues the discussion of the tone-forming circuits with a description of the Dual VCA module, which can be used in conjunction with the envelope shaper for dynamic control of signal amplitude, and also for periodic amplitude modulation of the signal waveform (tremolo).

The voltage controlled amplifier module is called a 'Dual VCA' because it contains two cascaded, but independently controlled, amplifiers. The gain of the first amplifier is voltage controlled via an exponential converter, and is used for envelope shaping. The second has a linear gain-control input and is used for periodic modulation of signal amplitude (tremolo). The VCA is provided with a modulation indicator, which allows the best compromise to be obtained between signal-to-noise and overload margin.

### Connection of the VCA in the synthesiser system

Figure 1 illustrates how the VCA fits into the synthesiser system. The VCA takes its input from the output of the VCF, which in turn takes its input signal from the VCOs.

The VCF and VCA can both be controlled by the ADSR envelope shapers, so allowing dynamic variation of tone colour and amplitude during the playing of a note. However, the VCF has a KOV input from the keyboard to allow it to function as a tracking filter, but the VCA lacks this, since there is no pitch related control of signal amplitude.

### Using the VCA and the VCF

It may be interesting at this point to spend a little time comparing and contrasting the effects produced by the VCA and VCF, and discussing how they are used to complement one another in the synthesiser system. As an example, consider the case where the VCA and VCF are both controlled by the same waveform from the envelope shaper, consisting of a rapid attack and a relatively slow exponential decay, as shown in figure 2a, and are fed with a 440 Hz sawtooth waveform.

If the VCF is used alone in the lowpass mode and the cutoff frequency of the

filter is initially set very low, the input signal will be completely suppressed. However, during the attack phase of the envelope control waveform the cutoff frequency of the filter will rise very rapidly, and the amplitude and harmonic content of the note will both increase as first the fundamental, then the harmonics, are passed. During the slow decay phase the note will die away slowly as the cutoff frequency falls, starting with the higher harmonics, then the lower harmonics, and finally the fundamental. The variation in turnover frequency of the filter is illustrated in figure 2b.

The tone thus produced is not unlike that of a clavichord, or of a piano which has had drawing pins stuck into the hammers to produce a jangly, honky-tonk effect.

If the same signal and control waveforms are fed to the VCA, the signal amplitude will rise rapidly as the gain increases during the attack phase, and will fall away slowly during the decay phase. However, the harmonic content of the signal will remain unaltered. The sound thus produced is similar to that of percussion instruments such as the piano and xylophone.

By varying the attack and decay times of the envelope shapers a wide variety of tone colour and amplitude dynamics can be produced using the VCF and VCA in conjunction.

### VCA design considerations

The dual VCA contains two amplifiers whose gains are independently voltage-controllable, and the design of the VCA poses certain problems, the principal one being that of obtaining adequate dynamic range, as is illustrated in figures 3a to 3d.

Figure 3a shows a control contour from the envelope shaper. At the peak of the control contour the VCA must have a finite maximum gain, which, for the purposes of the discussion, it will be assumed is unity, or 0 dB. At the beginning and end of the note the signal must be inaudible, which means that the gain of the amplifier should ideally be infinitesimally small at these moments in time. In practice, if the gain is around -70 dB then this will be adequate.

What happens if the dynamic range is inadequate is shown in figure 3b. Suppose the gain of the amplifier can be varied by a range of only 40 dB or so, and is set to 0 dB on the peak of the control contour. At the start and end of the note the signal will only be 40 dB down, and if the note is being played fortissimo then this residual signal will still be quite audible.

Another fault of badly-designed VCAs is illustrated in figure 3c. In this example, the VCA cuts off completely below a certain level of control voltage, and so misses part of the attack and decay period of the note. This might be said to be the opposite fault to that of

figure 3b, though it is not directly related to dynamic range, but rather to extreme non-linearity of the control characteristic.

Returning to the example of the VCA with only 40 dB dynamic range, if the gain is adjusted so that the signal is inaudible at the beginning and end of the note (i.e. some 70 dB down), it will only be able to increase by 40 dB when the control voltage is applied, instead of the 70 dB required to reach the 0 dB level. The result is an amplitude plateau, as shown in figure 3d.

As mentioned briefly earlier, control of the envelope shaping section of the VCA is carried out exponentially. This is to compensate for the logarithmic loudness response of the human ear. On the other hand control of the periodic amplitude modulation section (tremolo) is linear, since this gives the 'softest' and 'sweetest' sound to the tremolo effect.

### Principle of the Formant VCA

The VCA in Formant uses the CA3080 OTA as the controllable amplifier, as in the VCF. The principle of the Formant VCA is illustrated in figure 4. The input voltage  $U_i$  is converted to a proportional output current  $I_o = g_m \cdot U_i$ . However, since we are interested in voltage amplification this output current must be converted into an output voltage, and this is done simply by feeding the current through a load resistor  $R_L$  to produce an output voltage  $U_o = g_m \cdot U_i \cdot R_L$ .

The transconductance of the amplifier,  $g_m$ , may of course be varied by a control current  $I_{ABC}$ , as explained in chapter 6, and the gain of the VCA may thus be controlled - although at this stage of course it is a CCA!

The output of the OTA may not drive any external load in addition to  $R_L$ , as this would lower the load impedance and alter the gain, so the output of the OTA is connected to a voltage follower/buffer with a high input impedance.

Both sections of the VCA operate on the same principle. However, only the output of the second OTA is buffered, since it is this output that is connected to any external loads. As the output of the first OTA has no external connection it is simply connected to the input of the second OTA.

The OTA has one disadvantage that cannot be ignored. As mentioned in the previous chapter, its linearity is good only for small input signals (typically  $\pm 10$  mV) which is why a large degree of input signal attenuation is required. This means that the signal-to-noise ratio is not exceptionally good, and for this reason it is best to use the VCA with the largest possible input signal consistent with low distortion. A modulation indicator is provided, which allows the best compromise to be obtained between excessive noise, at low input levels, and distortion at high input levels.

Figure 1. Block diagram illustrating how the VCA fits into the Formant synthesiser system.

Figure 2. Envelope control of the VCF and VCA. The attack-decay contour of figure 2a, when applied to the VCF, varies the turnover frequency of the filter, which provides dynamic alteration in the tone colour of the sound (figure 2b). When applied to the VCA, the envelope contour alters the gain of the VCA, and thus the amplitude of the sound (figure 2c).

**Circuit of the VCA**

The complete circuit of the VCA is given in figure 5. The exponential converter built around IC1 and IC3 will immediately be recognised, since it is very similar to that used in the VCF. The input configuration, however, is much simpler, there being but one external input, ENV, from the envelope shaper. If required this can be switched out by setting S1 in position 'a', in which case a fixed gain results.

The gain/control voltage characteristic of the VCF is roughly 12 dB/volt, but as the use of the word 'roughly' suggests, the accuracy of this characteristic is relatively unimportant, unlike the octave/volt characteristics of the VCO and VCF. The ear is much less critical of amplitude errors than it is of frequency errors. The dB/volt characteristic of the VCA may be adjusted by P2, whilst P1 is an offset trimmer. The output current of the exponential converter controls the gain of the first OTA, IC6.

The linear voltage-current converter is constructed around IC2, which is connected as an inverting, summing amplifier. An input signal may be fed to P4 via the AM input socket, and a DC input voltage is available from P3 ('Gain'). Both these input voltages cause proportional currents to flow through R12 and R13, and since these currents cannot flow into the inverting input of the op-amp they flow round the feedback loop through T1, and into the control input of IC7.

The audio signal to the VCA comes either from the permanently wired internal signal input (IS) or from the external signal socket (ES) on the front panel of the VCA module. The amplitude of the external input signal is controlled by P5, whereas the amplitude of the internal signal is controlled at the IOS output of the VCF, by P6 of the VCF module.

IC4 functions as a summing amplifier with a gain of -1, and the signal level at the output of IC4 is monitored by the modulation indicator constructed around IC5. This is a non-inverting amplifier feeding a bridge rectifier D1 to D4, the output of which drives the modulation indicator LED D5. Once the

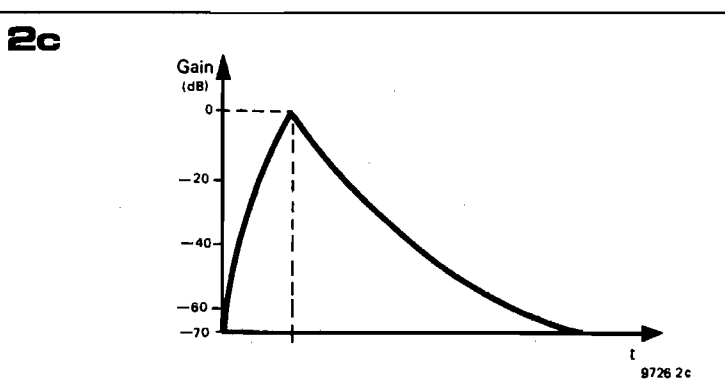
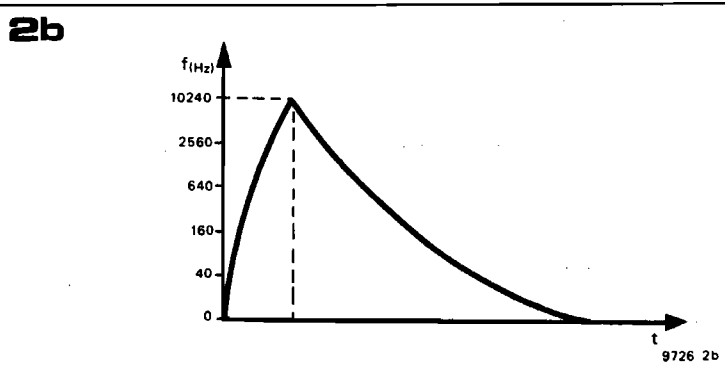
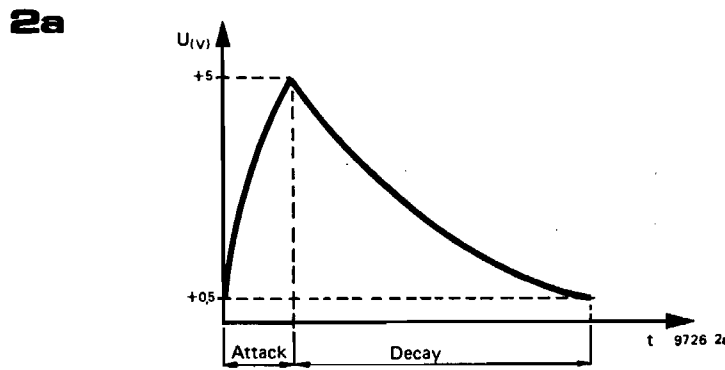
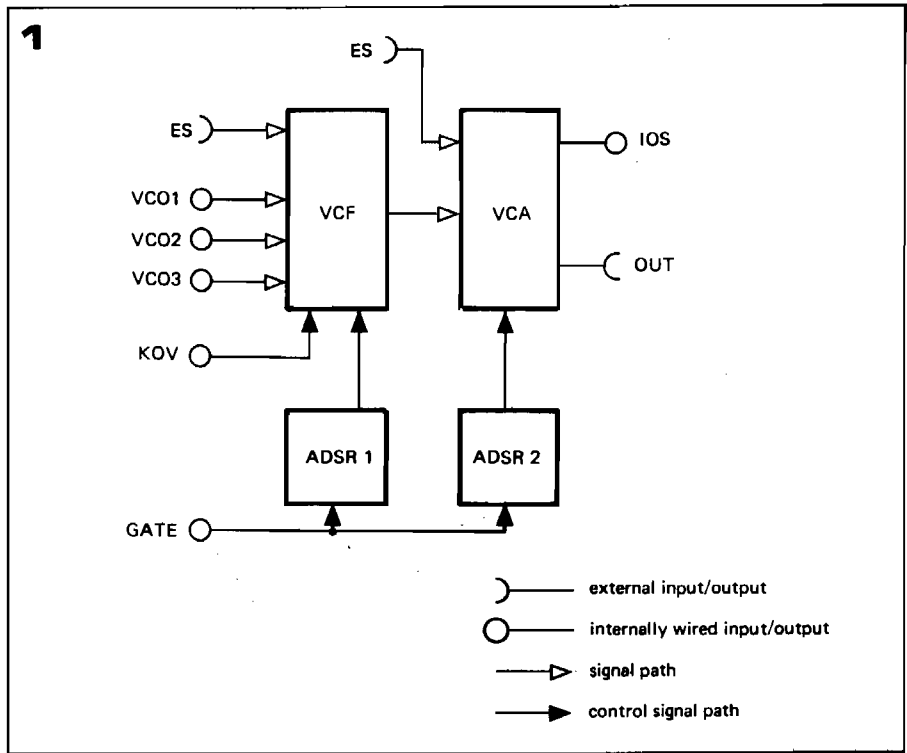



3a

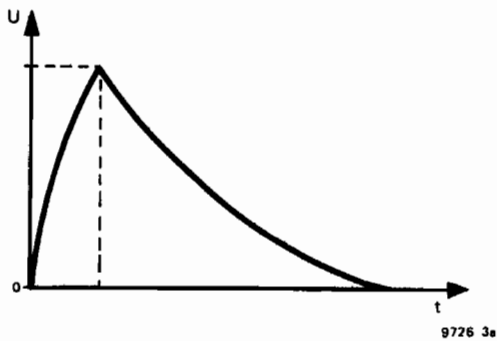

9726 3a

3b

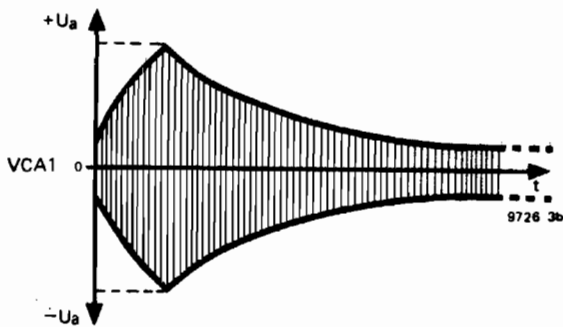

9726 3b

3c

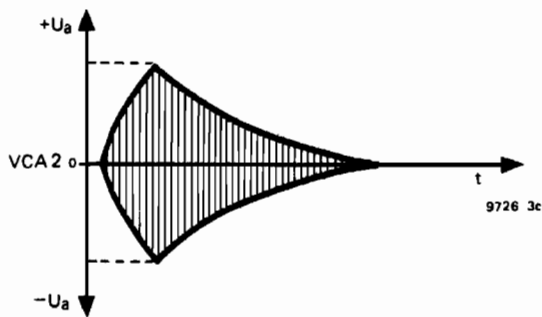

9726 3c

3d

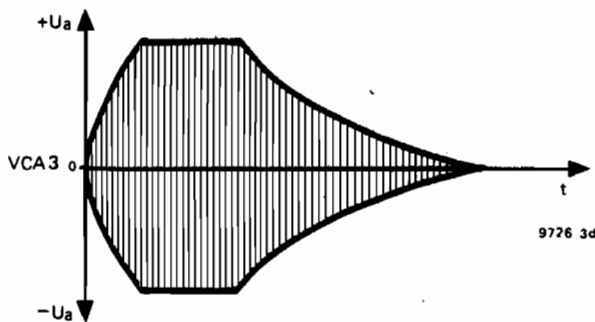

9726 3d

4

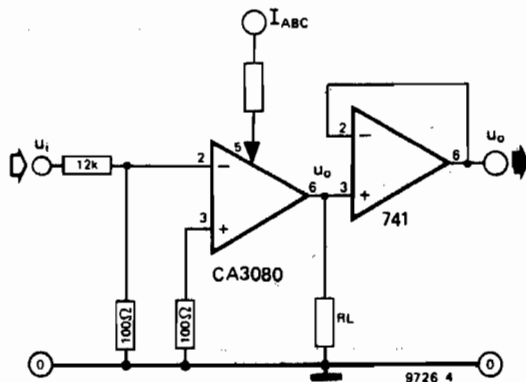

9726 4

peak signal level at the output of IC5 exceeds the combined knee voltages of D1 plus D5 plus D4 (or D3 plus D5 plus D2) then the LED will start to glow and will glow brighter as the signal level increases. P6 is used to adjust the gain of IC5 so that D5 starts to glow at the signal level where overmodulation begins to occur.

The output signal from IC4 is attenuated by R19 and R20 down to a level which the OTA, IC6, can handle. The output of the exponentially controlled OTA, IC6, is fed via a second attenuator R25/R26, to the input of the linearly-controlled OTA, IC7. The output of IC7 is buffered by voltage-follower IC8 and two outputs from the VCA are provided, an internally wired output, IOS, and an output to a front panel socket, EOS. Potentiometers P7 and P8 are provided for trimming the offset voltages of IC6 and IC7.

### Construction

The comments with regard to component quality that have been made in previous chapters apply equally to the construction of the VCA, and will not be repeated. A printed circuit board and component layout for the VCA are

Figures 3a to 3d. Some typical faults of badly-designed or badly-adjusted VCAs are illustrated here. None of the amplitude envelopes in figures 3b to 3d follows the control contour of figure 3a.

In figure 3b there is feedthrough of the signal after the control contour finishes; in figure 3c the signal is still cut off for some time after the control contour starts, and cuts off again before it finishes; in figure 3d the VCA has insufficient headroom and limits causing a 'plateau' on top of the envelope curve.

Figure 4. The principle of the Formant VCA is illustrated here. The OTA produces an output current proportional to the product of the input voltage and the control current  $I_{ABC}$ . This causes a voltage drop across the load resistor  $R_L$ , and the output is buffered by an op-amp voltage follower. The input attenuator is necessary to avoid overloading the OTA.

Figure 5. Complete circuit of the Formant Dual VCA. This contains two, cascaded, voltage-controlled amplifiers with independent control inputs; exponential control for envelope shaping and linear control for amplitude modulation (tremolo).

given in figure 6, and a front panel layout is given in figure 7.

### Testing and adjustment

For optimum performance the VCA must be matched to a particular envelope shaper, and thereafter the VCA and envelope shaper should be used as a pair. This is not necessary in the case of the VCF, which may be used with any envelope shaper.

To test and adjust the VCA, the completed keyboard and interface receiver must be available, together with VCOs, VCF and the envelope shaper to which the VCA is to be matched. The IOS output of the VCO is connected to one of the VCO inputs of the VCF, and the IOS output of the VCF is connected to the IS input of the VCA. The GATE output of the interface receiver is connected to the GATE input of the envelope shaper and output ENV of the envelope shaper is connected to input ENV of the VCA.

For the initial test, the sawtooth output of the VCO is selected and the output level is set to maximum. The VCF is set to the lowpass mode, but the turnover frequency is set to maximum by turning the octaves control fully clockwise. The

Q control is set to minimum, the KOV input is switched off and the output level is set to maximum.

- At the IOS output of the VCF, the sawtooth signal from the VCO should now be available in phase with, and at the same amplitude as, the VCO output (about 2.5 V p-p).

- At the output of IC4 of the VCA, the signal should be available at the same level, but inverted.

- With S1 of the VCA in position 'a' (ENV input switched off) and P7 and P8 in mid-position, the sawtooth signal should be available at the output of IC6 in phase with the VCO output, and the amplitude should be adjustable by P1.

- At the output of IC7 the signal should again be in phase, and both P1 and P3 should vary the amplitude.

- Finally, the signal should be available at outputs IOS and EOS.

This concludes the basic functional check of the VCA, and the adjustment procedure can now be carried out.

### Modulation Indicator

Using the same input signal, P6 is adjusted until the modulation indicator D5 just begins to glow. Increase the signal amplitude by switching in the

second and third VCOs, when the LED should glow brighter.

After this test, the second and third VCOs should be switched off again.

### Offset adjustment

Turn the output level of the VCF to zero and short the IS input of the VCA to ground. Set S1 of the envelope shaper to 'AD' and the A, D, S and R controls to minimum (shortest attack and decay, and 0% sustain). Turn P5 of the VCA fully anticlockwise, set S1 of the VCA to position 'b' (ENV) and observe the DC output voltage of IC6 on an oscilloscope.

When a key is depressed, a step output voltage will be observed at the output of IC6. This is the offset voltage of the IC, which is amplified as the gain of IC6 increases under the influence of the envelope control voltage; if it is not nulled out then it will break through to the output as 'cracks' or 'plops'. P7 is adjusted until the step voltage is as small as possible on the most sensitive range of the oscilloscope.

The offset nulling procedure must then be repeated for IC7. S1 is switched to the 'off' position, P3 is turned fully anti-clockwise and the external output of the envelope shaper is connected to

5

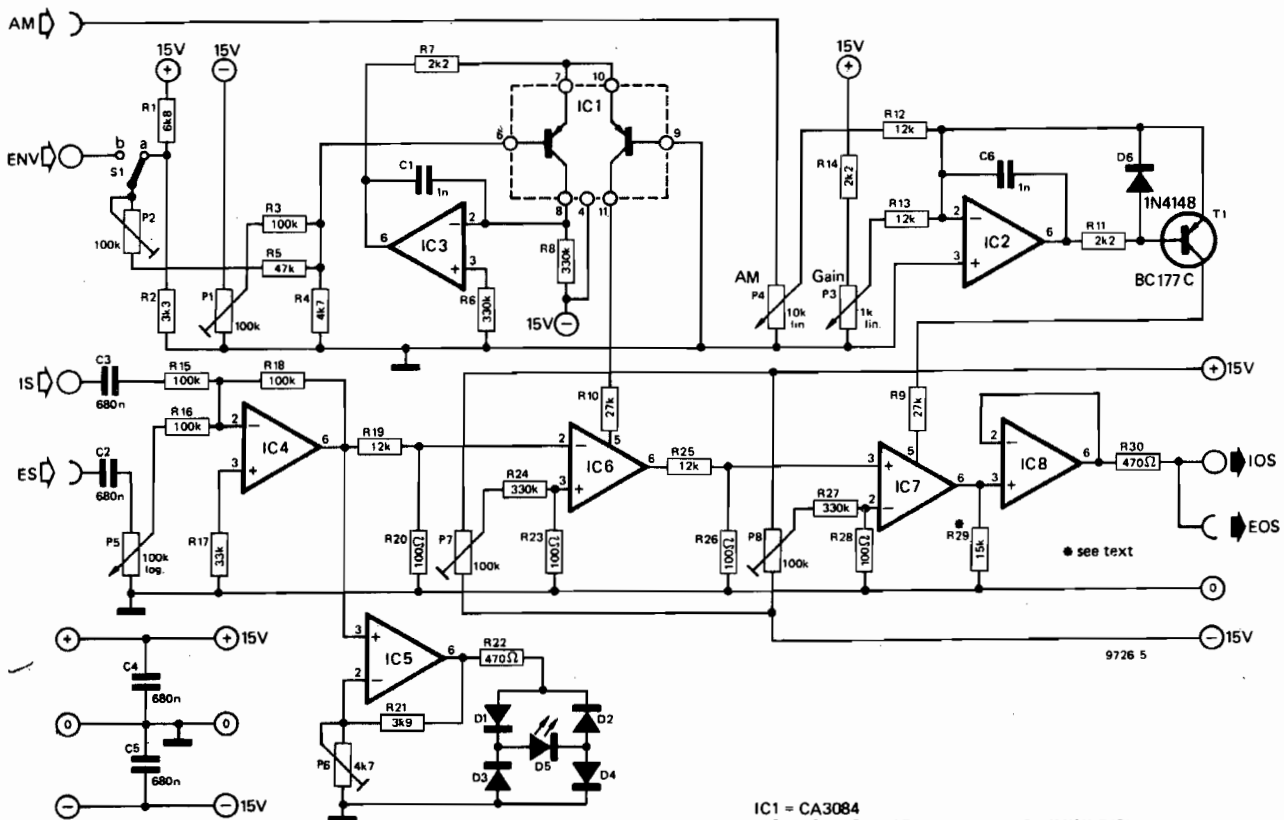

IC1 = CA3084  
 IC2 ... IC5, IC8 =  $\mu$ A741C, MC1741CP1 (MINI DIP)  
 IC6 ... IC7 = CA3080(A) (MINI DIP)  
 D1 ... D4 = OA91, AA119, AA118

6

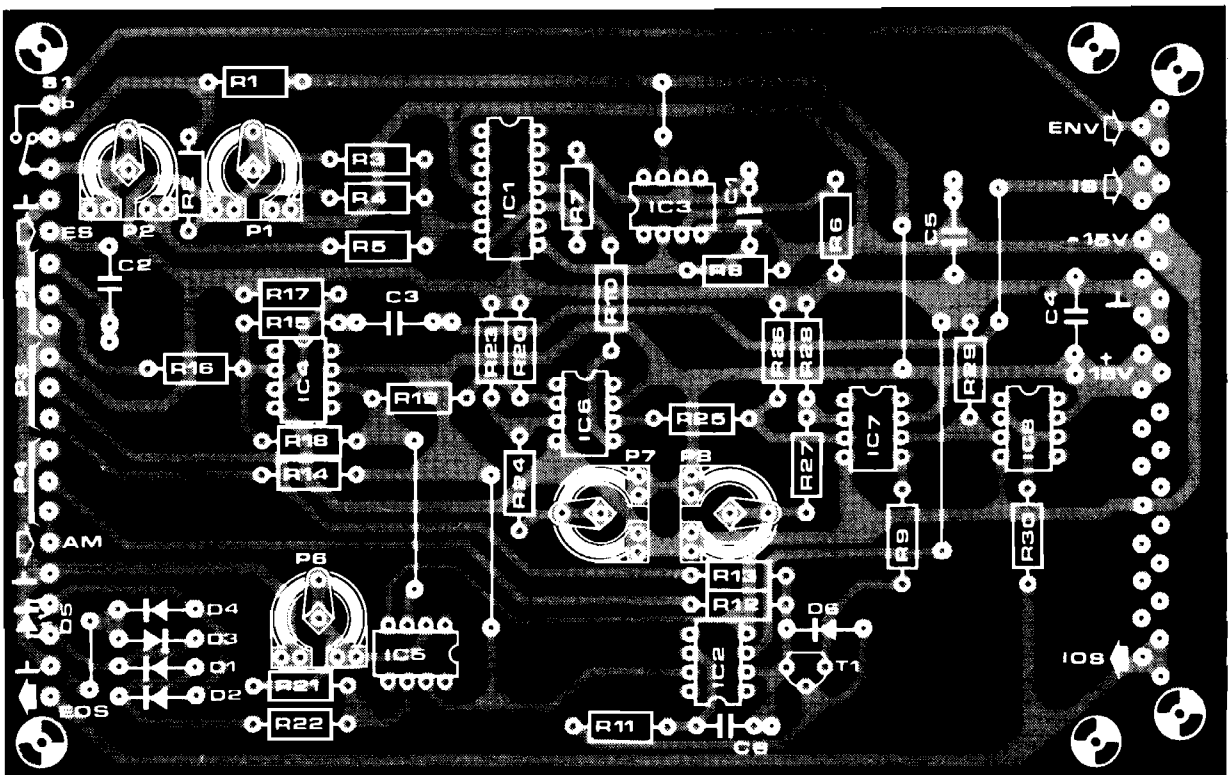
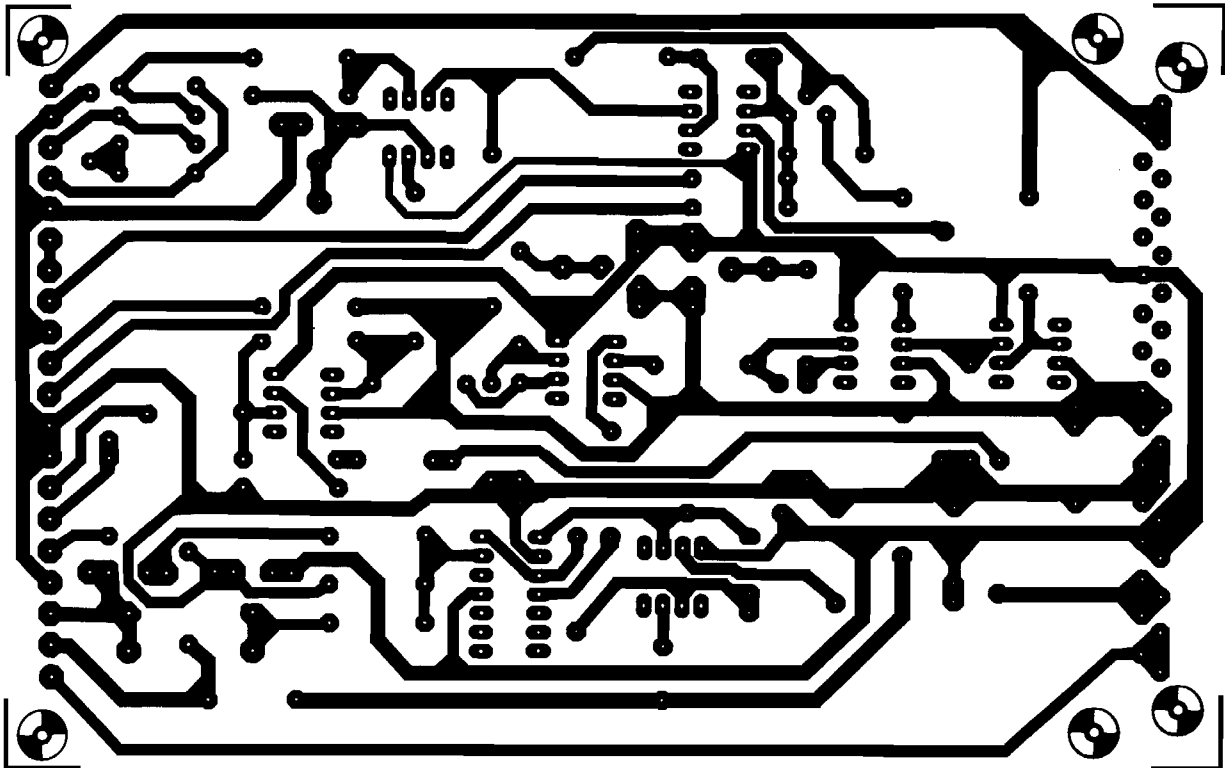

## Parts list for figures 5 and 6

## Resistors:

R1 = 6k8  
 R2 = 3k3  
 R3,R15,R16,R18 = 100 k  
 R4 = 4k7  
 R5 = 47 k  
 R6,R8,R24,R27 = 330 k  
 R7,R11,R14 = 2k2  
 R9,R10 = 27 k  
 R12,R13,R19,R25 = 12 k  
 R17 = 33 k  
 R20,R23,R26,R28 = 100  $\Omega$   
 R21 = 3k9  
 R22,R30 = 470  $\Omega$   
 R29 = 15 k (nominal value,  
 see text)

## Potentiometers:

P1,P2,P7,P8 = 100 k preset  
 P3 = 1 k lin.  
 P4 = 10 k lin.  
 P5 = 100 k log.  
 P6 = 4k7 (5 k) preset

## Capacitors:

C1,C6 = 1 n  
 C2,C3,C4,C5 = 680 n

## Semiconductors:

IC1 = CA 3084 (DIL package)  
 IC2,IC3,IC4,IC5, IC8 =  $\mu$ A 741C,  
 MC 1741 CP1 (Mini DIP)  
 IC6,IC7 = CA 3080 (A)  
 T1 = BC 177B, BC 178C, BC 179C,  
 BC 557B, BC 558C, BC 559C  
 D1 ... D4 = DUG (OA91,  
 AA118, AA119)  
 D5 = LED (TIL 209 or similar)  
 D6 = 1N4148

## Miscellaneous:

31-way Euro connector  
 (DIN 41617)  
 S1 = SPST miniature toggle  
 switch  
 3 off, 3.5 mm jack socket  
 3 off, 13-15 mm collet knobs with  
 pointer

Figure 6 Printed circuit board and component layout for the VCA (EPS 9726-1).

Figure 7 Front panel layout of the VCA. S1 is located between the AM and ES input sockets. Immediately below these sockets are the respective input level controls: P4 sets the AM modulation depth and P5 is the external input level control. Below these again are the modulation indicator (D5), the manual gain control (P3) and the output socket (EOS).

the AM input of the VCA. The IOS output of the VCA is monitored on the oscilloscope and the offset nulling procedure is repeated, this time using P8.

**Adjustment of exponential gain control**

The exponential converter must be adjusted so that the required gain control range of IC6 is obtained from the +0.5 V to +5 V range of the envelope shaper.

S1 of the envelope shaper is set to the 'AD' position and fairly short attack and decay times are selected. The short circuit across the VCA input is removed, the VCF level control is turned to maximum and a signal is fed in from one of the VCOs. P2 on the VCA board is initially set to its mid-position.

The output of IC6 is now monitored with an oscilloscope and a key is repeatedly depressed, when AD envelope curves should be seen. P1 is then adjusted for minimum feed through when the key is not depressed, less than one or two millivolts will be acceptable. The Y sensitivity of the oscilloscope is now adjusted so that the entire envelope curve can be seen when a key is depressed. P2 should then be adjusted until a good attack/decay curve without limiting (seen as a flat top or plateau as

shown in figure 3d) is just obtained. Since P1 and P2 interact to some extent, it may be necessary to repeat the adjustment procedure several times to obtain the best results.

**Adjustment of overall gain**

The overall gain of the VCA should be 0 dB (unity) at maximum modulation of IC6 and IC7. To achieve this it may be necessary to alter the value of R29, which is nominally 15 k. Set the gain control P3 to maximum, and the envelope shaper to the 'ADSR' mode with 100% sustain. A key is now depressed and held down, and the output level of the VCA (at IOS or EOS) is compared with the input level at IS. These levels should be the same; if the output level is too low, then R29 must be increased in value, and if the output level is too high then R29 must be reduced. A 3 dB difference ( $\times 0.707$  or  $\times 1.414$ ) between the input and output levels is acceptable.

This completes the adjustment of the VCA.

**Use of the VCA**

The input signal level to the internal input of the VCA is controlled by the output potentiometer of the VCF. In

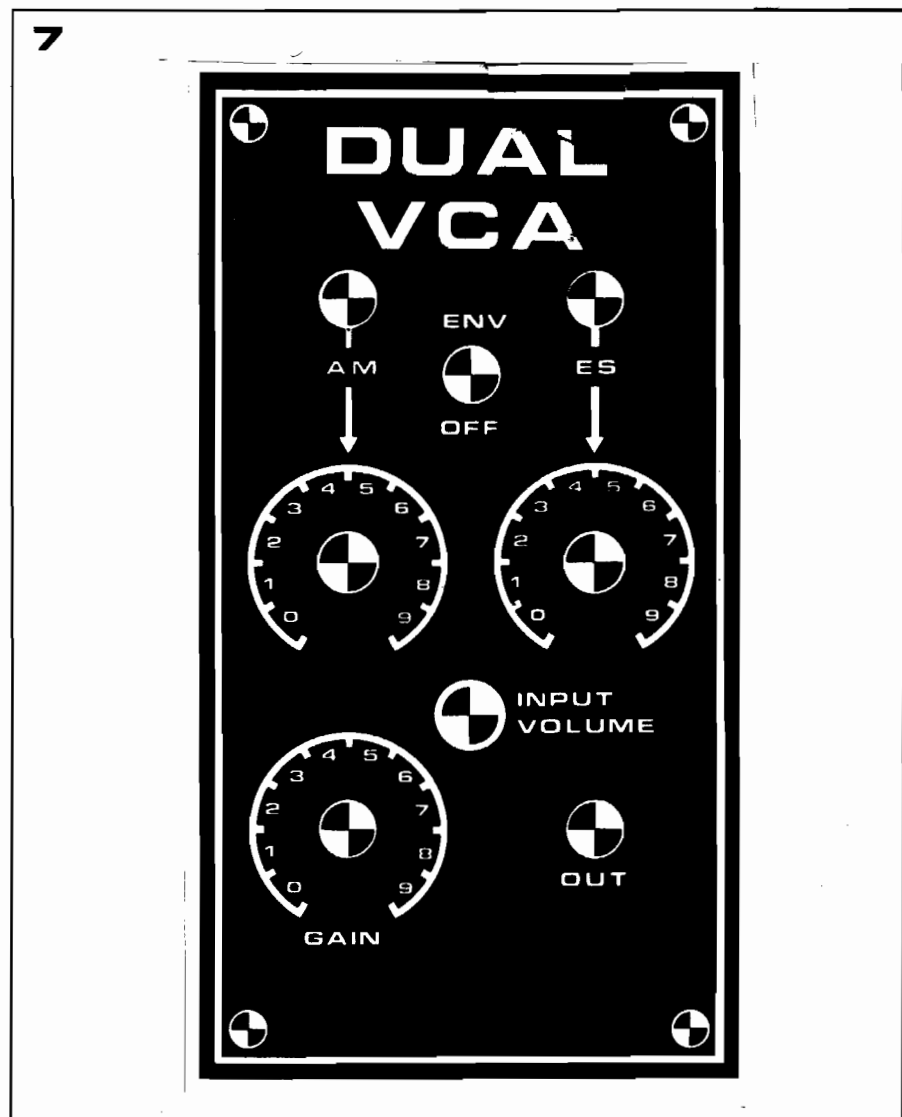

normal use this control should be adjusted so that the LED just begins to glow, which occurs at a nominal level of 2.5 V p-p with one VCO input signal, less if more than one VCO is connected. If the LED glows brightly, then the VCA is being overmodulated and distortion may occur. This is not to say that this should never be allowed to happen, since the deliberate introduction of distortion can be used to produce 'fuzz' effects. If the LED does not glow, then this indicates under-modulation and the possibility of a poor signal-to-noise ratio.

#### Tremolo

To produce tremolo effects a low-frequency oscillator signal (LFO) can be fed into the AM input socket. The Formant LFOs, described later in the series, have an output voltage swing of  $\pm 2.5$  V, and if the GAIN potentiometer P3 is set in its mid-position this will give a modulation depth of 100%. Reducing the LFO input signal by means of the AM potentiometer P4 allows the modulation depth to be varied down to 0%.

#### Expression Pedal

An expression pedal may also be connected to the AM input. This can be a pedal fitted with a logarithmic potentiometer and battery, whose output can be varied from zero to about +5 V with the pedal fully depressed.

#### Tuning

The ENV/OFF switch S1 is particularly useful when tuning the synthesiser, since it allows signals to pass continuously through the VCA, unaffected by the envelope shaper when in the OFF position.

#### Outputs

The external output of the VCA has an impedance of about 500  $\Omega$ , and this output may be fed to other equipment such as tape decks and external amplifiers, or to high impedance headphones for monitoring.

The internal output signal (IOS) is taken to the Formant amplifier module, which will be described later. This is fitted with tone and volume controls and a small power amplifier for monitoring purposes. It will drive low impedance headphones and loudspeakers, and can also be used to drive spring line reverb units or other external equipment.

## chapter 11

### LFOs and noise module

**The low frequency oscillators and noise generator are invaluable components in a synthesiser system. The LFOs allow amplitude and frequency modulation of the VCO outputs to provide tremolo, vibrato and other effects. The noise sources can be used for random modulation of the VCO signals, and in addition can be used as signal sources themselves.**

Mention has already been made of the fact that conventional instruments exhibit more 'life' and variation in tonal character than electronic instruments due to the way in which they are played. For example, string instruments and woodwind instruments can exhibit marked tremolo and/or vibrato due to variations in the stopping or blowing. The keyboard of a synthesiser provides a relatively inflexible and expressionless means of playing that does not allow these nuances to be introduced into the sound, and in order to make the sound more 'lively' amplitude and frequency modulation must be introduced using the LFOs and noise source.

The noise source also provides the basic material to produce a whole spectrum of sounds that do not have a defined pitch. White noise can be used to produce sounds such as wind, rain and surf. 'Coloured' noise, which is white noise with the low frequency components boosted, is used for sounds having a strong bass content, such as the rumbling of thunder.

In addition to modulating the VCO signals, noise can also be added to these signals to simulate wind noise in organ pipes and woodwind instruments.

#### The LFO module

The Formant LFOs are basically low-frequency function generators that produce three different waveforms. Each LFO module contains three LFOs, two of which are identical and produce square, triangle and sawtooth

waveforms. The third LFO produces a triangular waveform and two sawtooth waveforms in antiphase with each other, i.e. one with a positive-going ramp and the other with a negative-going ramp.

The circuit of LFO1 is shown in figure 1a; LFO2 is identical. The basic oscillator circuit consists of two op-amps IC1 and A3 connected respectively as an integrator and a Schmitt trigger. When the output of A3 is positive a potential of about +2.5 V (depending on the position of the wiper of P3) is applied to R9. The full positive output voltage of A3 is applied to P1, so a current (dependent on the wiper position of P1) flows into the integrator through R1. The output of IC1 ramps negative until it reaches about -2.5 V, when the voltage on the non-inverting input of A3 will fall below the voltage on the inverting input (zero volts) and the output of A3 will swing negative. The voltage applied to R9 is now -2.5 V, and the full negative output voltage of A3 is applied to P1. Current will flow out of the integrator through R1, and the integrator output will ramp positive until it reaches about +2.5 V, when the voltage on the non-inverting input of A3 will rise above zero and the output of A3 will swing positive. The whole cycle then repeats.

The output from IC1 is thus a triangular waveform with a peak-to-peak voltage of about 5 V, while at the wiper of P3 a squarewave of the same amplitude and frequency is available. P3 presets the trigger threshold of A3 and hence the signal amplitude. P1 is used to adjust the frequency of the LFO by varying the voltage applied to the integrator input, which alters the integrator input current and hence the rate at which the integrator ramps positive or negative.

The triangular wave output is taken direct from IC1 via R13, whilst the squarewave output is buffered by voltage follower A4. The sawtooth waveform is derived from the triangle by A2. When the output of A3 is positive and the triangle output is on its negative-going slope, T1 is turned on, grounding the non-inverting input of A2. A2 thus functions as a unity-gain inverting amplifier, producing a positive-going ramp. When the output of A3 is negative and the output of IC1 is positive going, T1 is turned off and A2 functions as a unity-gain non-inverting amplifier (voltage follower), again producing a positive-going ramp. The positive- and negative-going ramps of the triangular waveform are thus converted into a series of positive-going ramps. Since every half-cycle of the triangle is converted into a full cycle of the sawtooth, the frequency of the sawtooth is twice that of the triangle and square waveforms, as illustrated in figure 2.

To indicate that the LFO is functioning a LED indicator, constructed around A1, is connected to the triangle output.

Figure 1a. Circuit of LFO 1, which is identical to LFO 2 and produces triangle, sawtooth and square waveforms.

Figure 1b. LFO 3 also produces three waveforms, but instead of a squarewave output a negative-going sawtooth is provided.

The third LFO circuit, shown in figure 1b, is similar to the first circuit, with two exceptions. Firstly, no squarewave output is provided; secondly, a sawtooth with negative-going slope is provided by A8, which inverts the positive-going sawtooth from A6.

**Construction of the LFO module**

Figure 3 shows the printed circuit board and component layout of the LFO module, which of course contains three LFOs. The components for LFO2 are identical to those for LFO1, being distinguished on the board and in the components list by an apostrophe ('). The board layout is fairly cramped, and care should be taken when soldering components to avoid solder bridges. A front panel layout is given in figure 4.

**Adjustment of the LFOs**

- Each LFO requires four adjustments:
- P3, P3' and P7 set the signal amplitude.
  - P2, P2' and P5 null the offset of the integrators.
  - R16, R16' and R17 must be selected to set the lowest frequency of the LFO.
  - P4, P4' and P6 adjust the LED indicators.

The adjustment procedure, which is identical for all three LFOs, will be described for LFO1.

**Amplitude adjustment**

1. Monitor the triangle output on an oscilloscope; set P2 to its mid-position and P1 for maximum frequency.
2. Adjust P3 to give a peak-to-peak output of 5 V.
3. Check the amplitude and waveform of the other outputs.

**Offset adjustment**

1. Disconnect R1 from the wiper of P1 and ground it.
2. Monitor the output voltage of IC1 with a multimeter. It will probably exhibit a tendency to drift positive or negative, and the voltage will settle at +15 V or -15 V. Reset the

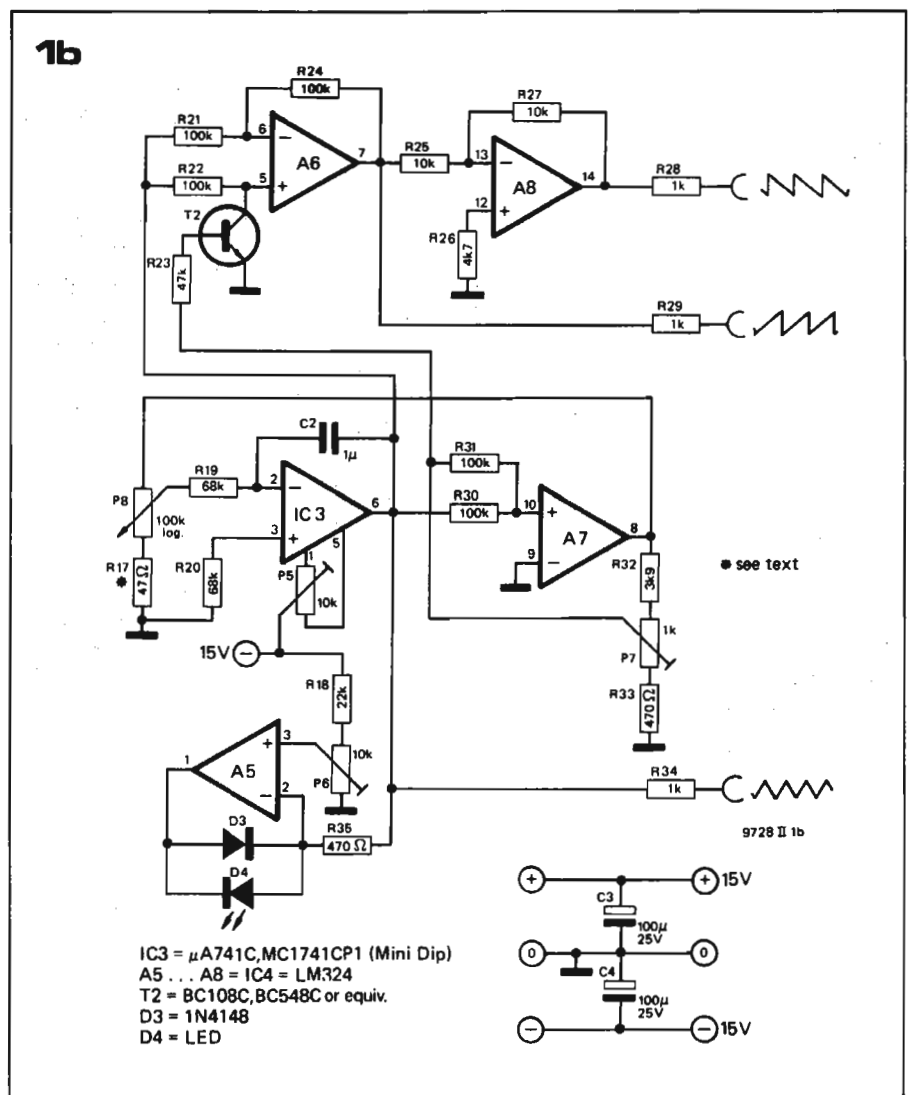
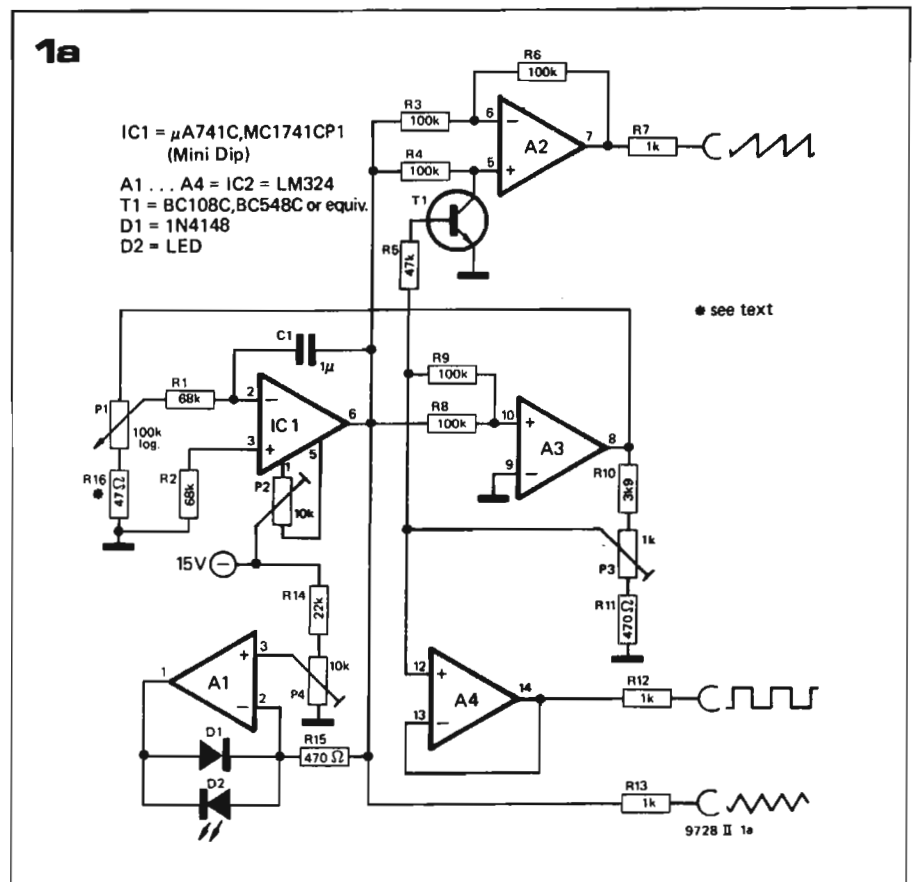

2

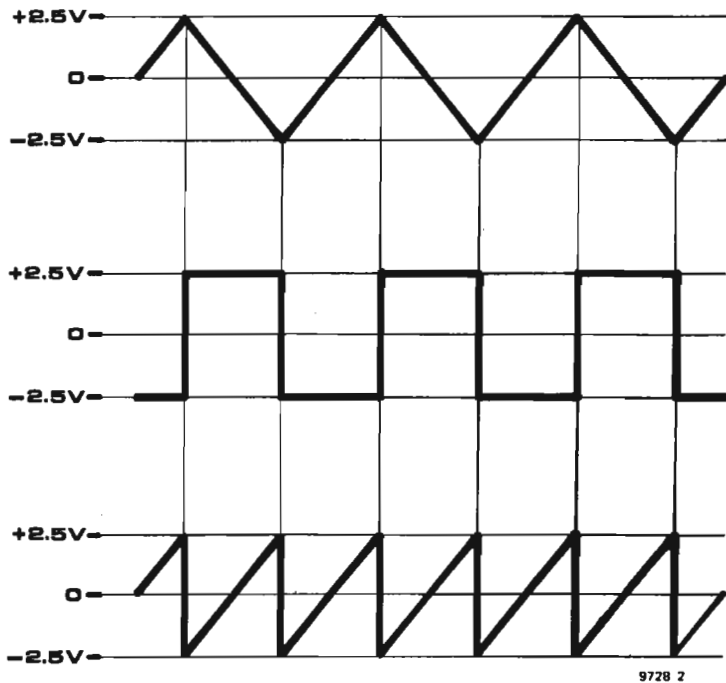
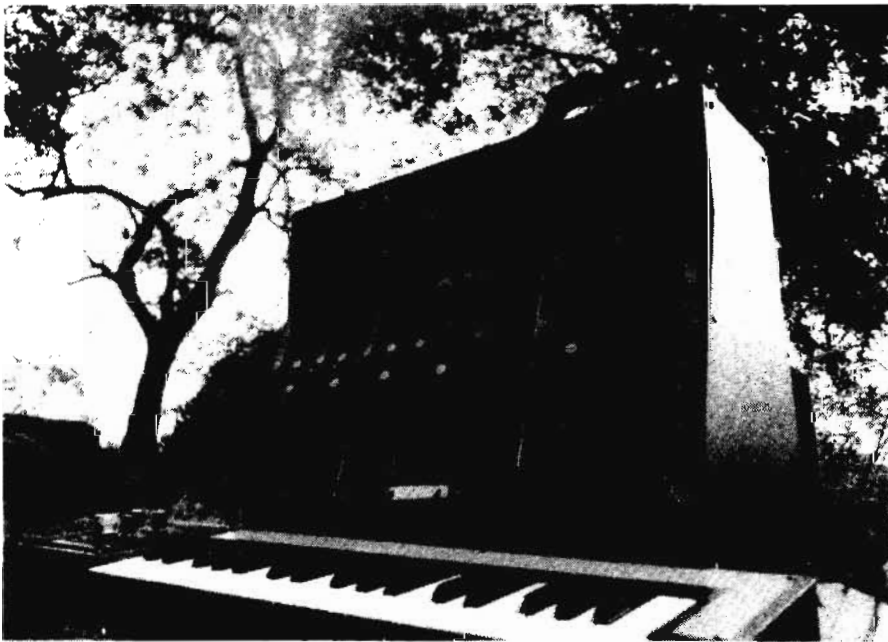

Figure 2. Showing the phase relationship of the triangle, square and sawtooth waveforms. Since the sawtooth is derived by inverting alternate half-cycles of the triangle waveform, its frequency is twice that of the other waveforms.

Figure 3. Printed circuit board and component layout for the LFO module (EPS 9727-1).



output voltage to zero by discharging C1 through a 1 k resistor. Adjust P2 until the voltage remains stable at zero volts for a period of several seconds (without the discharge resistor in circuit). Repeat this adjustment, progressively switching the multimeter to more sensitive ranges until the drift is only a few hundred millivolts in several seconds.

Careful adjustment of the offset is vital, as it determines the minimum frequency at which the LFO will operate

reliably and the symmetry of the waveforms at low frequencies.

#### Selection of R16

The value of R16 determines the minimum integrator input voltage that can be set by P1, and hence the minimum frequency of the LFO. The value of R16 must not be chosen too high or the minimum LFO frequency will be too great. On the other hand it should not be chosen too low, or the integrator input current at the minimum

setting of P1 will be comparable with the input currents of IC1. This will result in unreliable operation of the oscillator at low frequencies.

R16 should be chosen so that the minimum frequency of the LFO is about one cycle every three minutes, but the value of R16 should not be less than  $10\ \Omega$ . If it is not possible to obtain this low frequency then the input currents of IC1 may be too high, or C1 may be leaky.

The maximum LFO frequency is about 20 Hz.



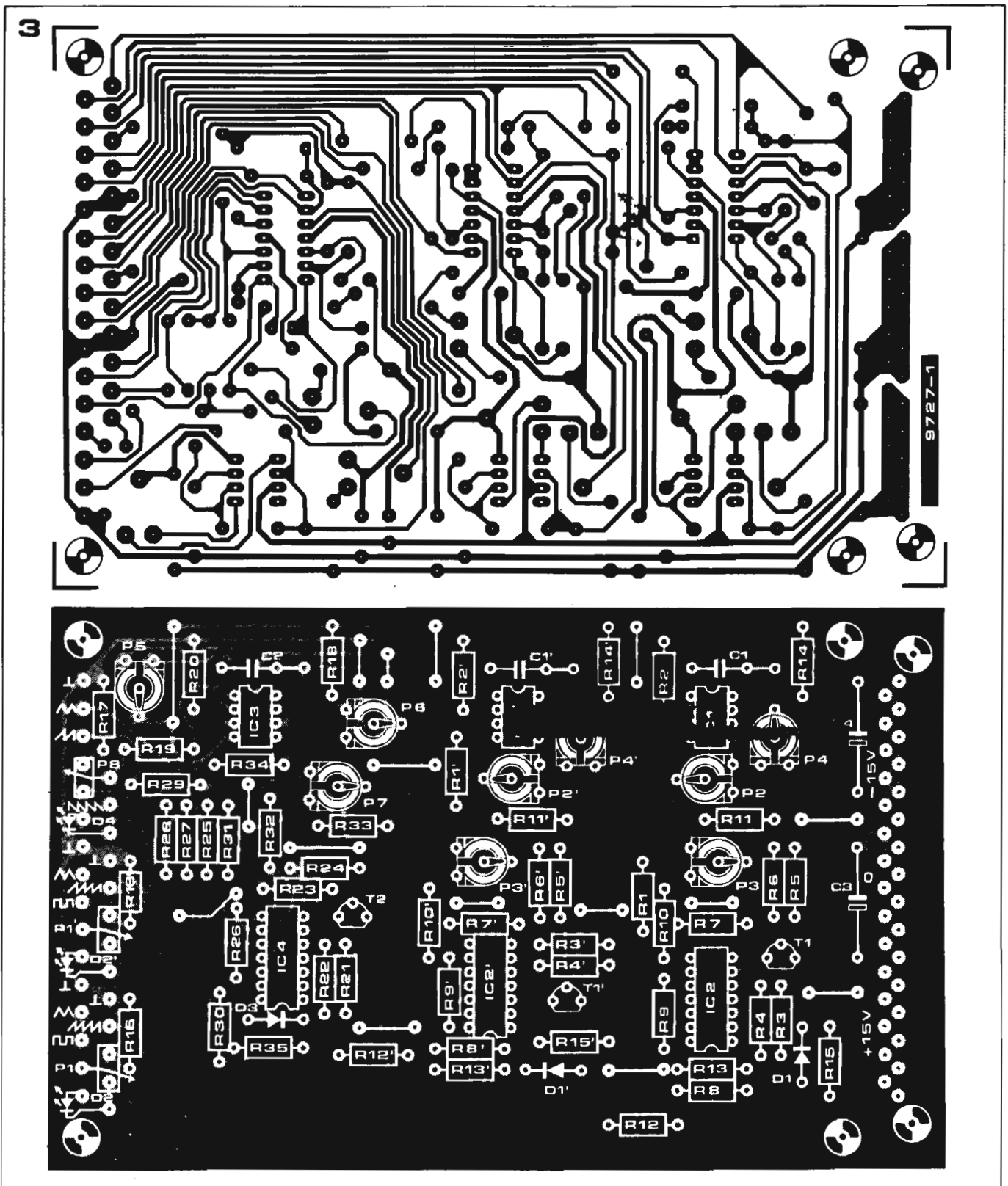

#### Parts list for LFO module

##### Resistors:

R1,R1',R2,R2',R19,R20 = 68 k  
 R3,R3',R4,R4',R6,R6',R8,R8',  
 R9,R9',R21,R22,R24,R30,  
 R31 = 100 k  
 R5,R5',R23 = 47 k  
 R7,R7',R12,R12',R13,R13',R28,  
 R29,R34 = 1 k  
 R10,R10',R32 = 3k9

R11,R11',R15,R15',R33,

R35 = 470  $\Omega$   
 R14,R14',R18 = 22 k  
 R16,R16',R17 = 47  $\Omega$  (see text)  
 R26 = 4k7

##### Potentiometers:

P1,P1',P8 = 100 k log  
 P2,P2',P4,P4',P5,P6 = 10 k preset  
 P3,P3',P7 = 1 k preset

##### Semiconductors:

IC1,IC1',IC3 =  $\mu$ A 741C,  
 MC 1741CP1 (Mini DIP)  
 IC2,IC2',IC4 = LM 324 (DIP)  
 T1,T1',T2 = BC 108C, BC 548C or  
 equivalent  
 D1,D1',D3 = 1N4148, 1N914  
 D2,D2',D4 = LED (e.g. TIL209)

##### Capacitors:

C1,C1',C2 = 1  $\mu$  (polyester or  
 polycarbonate)  
 C3,C4 = 100  $\mu$ /25 V

##### Miscellaneous:

31-way connector (DIN 41617)  
 9 x 3.5 mm jack  
 3 x 13... 15 mm knobs

4

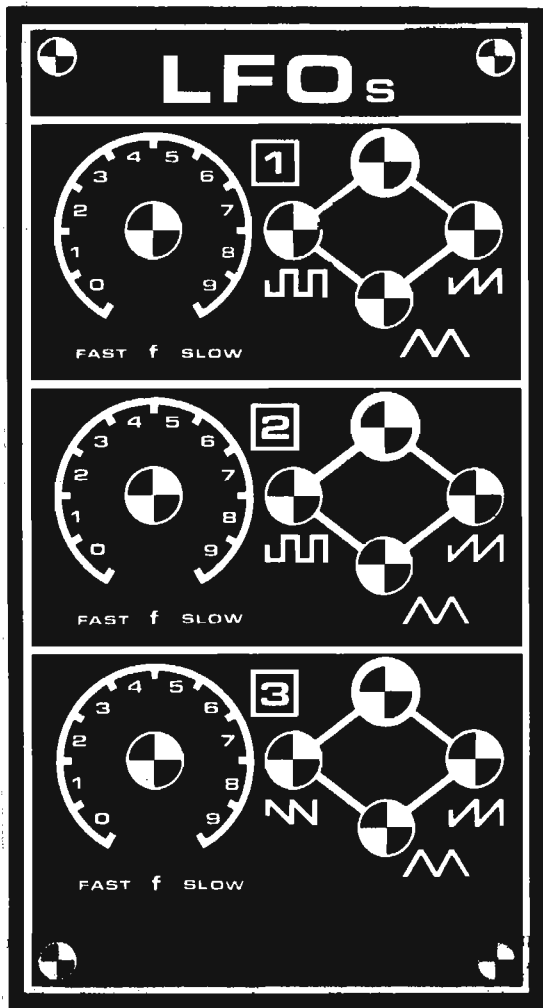
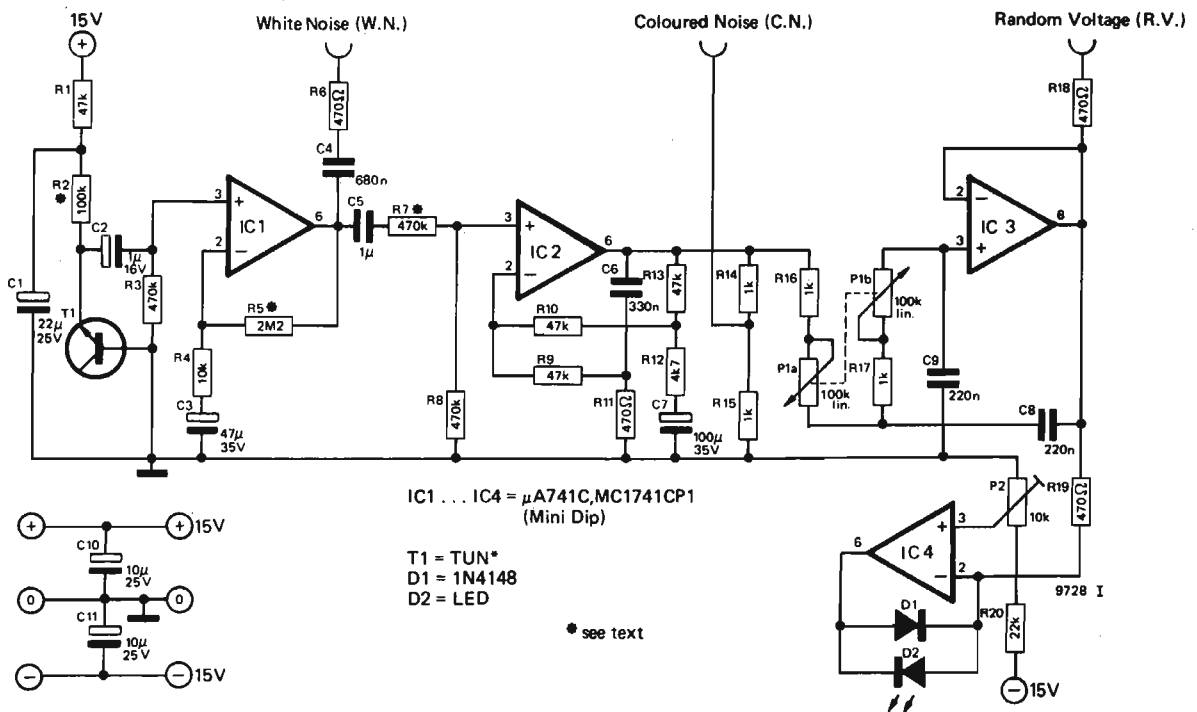

Figure 4. Front panel layout of the LFO module.

Figure 5. Circuit of the noise module.

Figure 6. Printed circuit board and component layout for the noise module (EPS 9728-1).

5



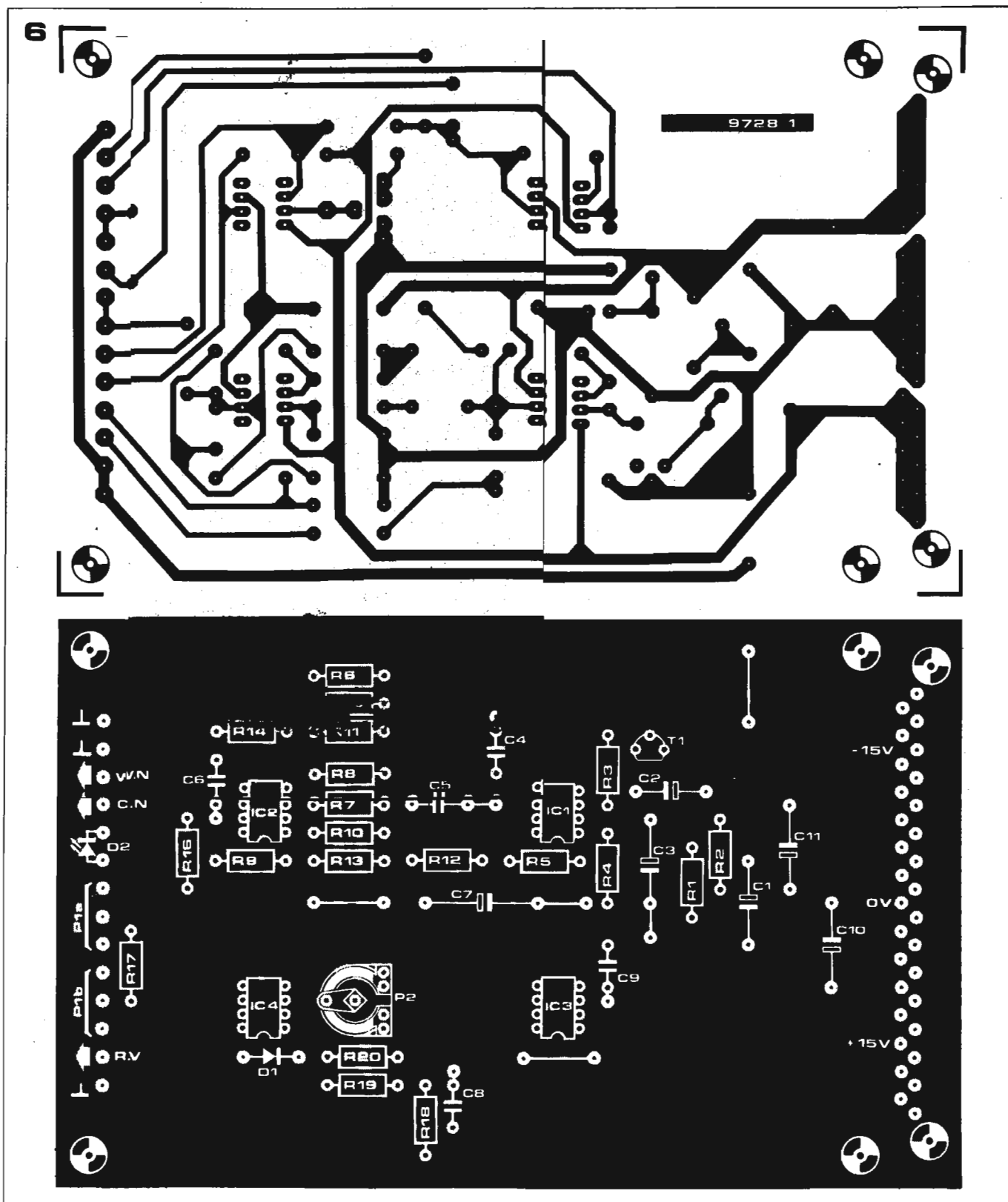

## Parts list for noise module

## Resistors:

R1,R9,R10,R13 = 47 k  
 R2 = 100 k (see text)  
 R3,R7,R8 = 470 k  
 R4 = 10 k  
 R5 = 2M2 (see text)  
 R6,R11,R18,R19 = 470 Ω  
 R12 = 4k7  
 R14,R15,R16,R17 = 1 k  
 R20 = 22 k

## Capacitors:

C1 = 22 μ/25 V  
 C2 = 1 μ/16 V  
 C3 = 47 μ/35 V  
 C4 = 680 n  
 C5 = 1 μ (polyester or polycarbonate)  
 C6 = 330 n  
 C7 = 100 μ/35 V  
 C8,C9 = 220 n  
 C10,C11 = 10 μ/25 V

## Semiconductors:

IC1,IC2,IC3,IC4, = μA 741C,  
 MC1741CP1 (Mini DIP)  
 T1 = TUN (selected)  
 D1 = 1N4148, 1N914  
 D2 = LED (e.g. TIL 209)

## Potentiometers:

P1 = 100 k lin. ganged  
 potentiometer  
 P2 = 100 k preset

## Miscellaneous:

1 x transistor socket  
 1 x 31-way connector (DIN  
 41617)  
 3 x 3.5 mm jack sockets  
 1 x 13 ... 15 mm knob

### Adjustment of the LED indicator

P4 should be adjusted so that the brightness of the LED follows the amplitude of the triangle output, i.e. the LED should be at minimum brightness when the triangle voltage is at its most negative, and at maximum brightness when the triangle is at its most positive. P4 should be adjusted so that the LED brightness does not reach maximum before the peak of the triangle, but on the other hand it should not extinguish completely before the trough of the triangle.

### The noise module

The complete circuit of the noise module is shown in figure 5. The noise is produced by the base-emitter junction of an NPN transistor T1, which is reverse-biased. The noise is amplified to a level of about 2.5 V peak-to-peak. This white noise output is fed out via C4 and R6.

The white noise is also fed into a filter constructed around IC2, which has two frequency dependent elements in the feedback path. These two elements interact as follows. On its own, the feedback network comprising R10, R12, R13 and C7 would produce a 6 dB/octave rise in the gain of IC2, from 0 dB at zero Hz via 3 dB at 9 Hz to approximately 20 dB at 90 Hz. The feedback network R9, R11, C6, on its own would produce a 6 dB/octave fall in gain from 0 Hz to 1 kHz, above which the gain would remain constant at 0 dB.

The combined effect of these feedback networks is that below 90 Hz the 6 dB/octave rise and 6 dB/octave fall cancel out, giving a gain of 20 dB. Above 90 Hz the gain falls at 6 dB/octave to 0 dB at 1 kHz, above which it remains constant. The result is that the bass end of the noise spectrum is boosted, and 'coloured' noise is available at the output of IC2. The coloured noise output is taken from the junction of R14 and R15.

The coloured noise output is also fed to a second filter built around IC3. This is a 12 dB/octave lowpass filter with variable turnover frequency, which passes only the very low frequency components to produce an extremely low frequency 'random voltage'. The fluctuation rate of this random voltage is adjusted by means of P1, which varies the turnover frequency of the filter. Fluctuations of the random voltage are displayed on a LED indicator, which is identical to those used in the LFOs.

### Construction and adjustment of the noise module

A printed circuit board and component layout for the noise module are given in figure 6, and the front panel layout is given in figure 7.

As not all transistors are suitable noise generators, a socket should be fitted in

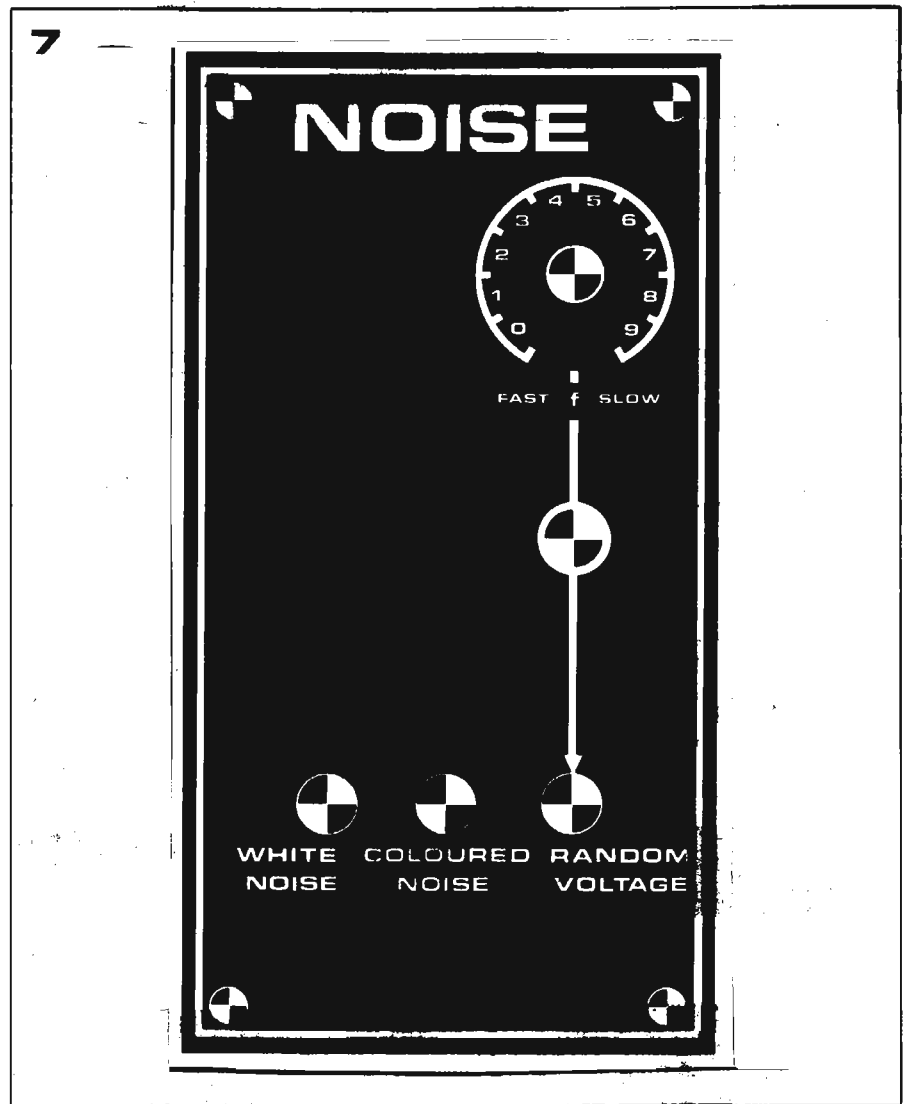

Figure 7. Front panel layout of the noise module.

the T1 position on the board so that different transistors may be tried. Measuring with a multimeter on a suitable AC voltage range at the white noise output, a voltage of 0.5 V to 0.8 V should be present. Alternatively, if an oscilloscope is used to monitor the output, a noise signal of about 2 V to 2.8 V peak-to-peak should be obtained. It may be necessary to try several transistors before a suitable one is found. Varying the value of R2 between 33 k and 150 k may also help.

If the transistor produces too high a noise level this can be reduced by making R5 smaller, thus reducing the gain of IC1.

The amplitude of the coloured noise output should also lie in the same range as the amplitude of the white noise output. If it is too small then R7 should be reduced and if it is too large R7 should be increased.

The random voltage output should vary between about +2.5 V and -2.5 V with P1 in the 'fast' position.

The final adjustment to the noise module is to set P2 so that the LED brightness indicates the amplitude of the random voltage output in a linear manner. This adjustment is carried out in exactly the same way as the adjustment of the LFO indicators.

chapter 12

COM

With a description of the COM (Control and Output Module), and an overall wiring diagram for the 'basic' Formant system, this chapter brings Part 1 of the book, which has dealt with the design and constructional aspects of the various Formant modules, to a close.

The COM contains a tone control amplifier with bass, middle, treble and volume controls, and an output buffer capable of driving high impedance (> 600 Ω) headphones for monitoring or practice purposes. The COM front panel also contains the indicator LEDs for the three power supply voltages and the gate signal. These indicators should not be regarded merely as a gimmick but as an important aid to monitoring the state of the Formant system. A fault in any of the supply voltages is immediately indicated by one of the LEDs, as is the absence of a gate pulse.

COM circuit

The complete circuit of the COM is given in figure 1a.

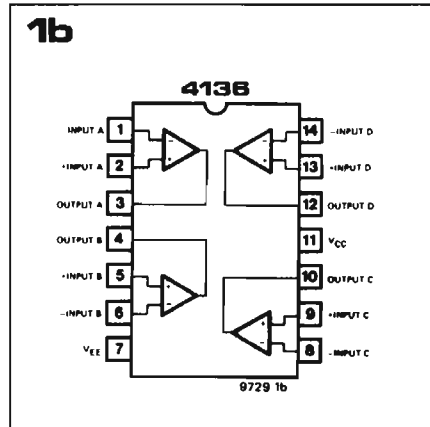
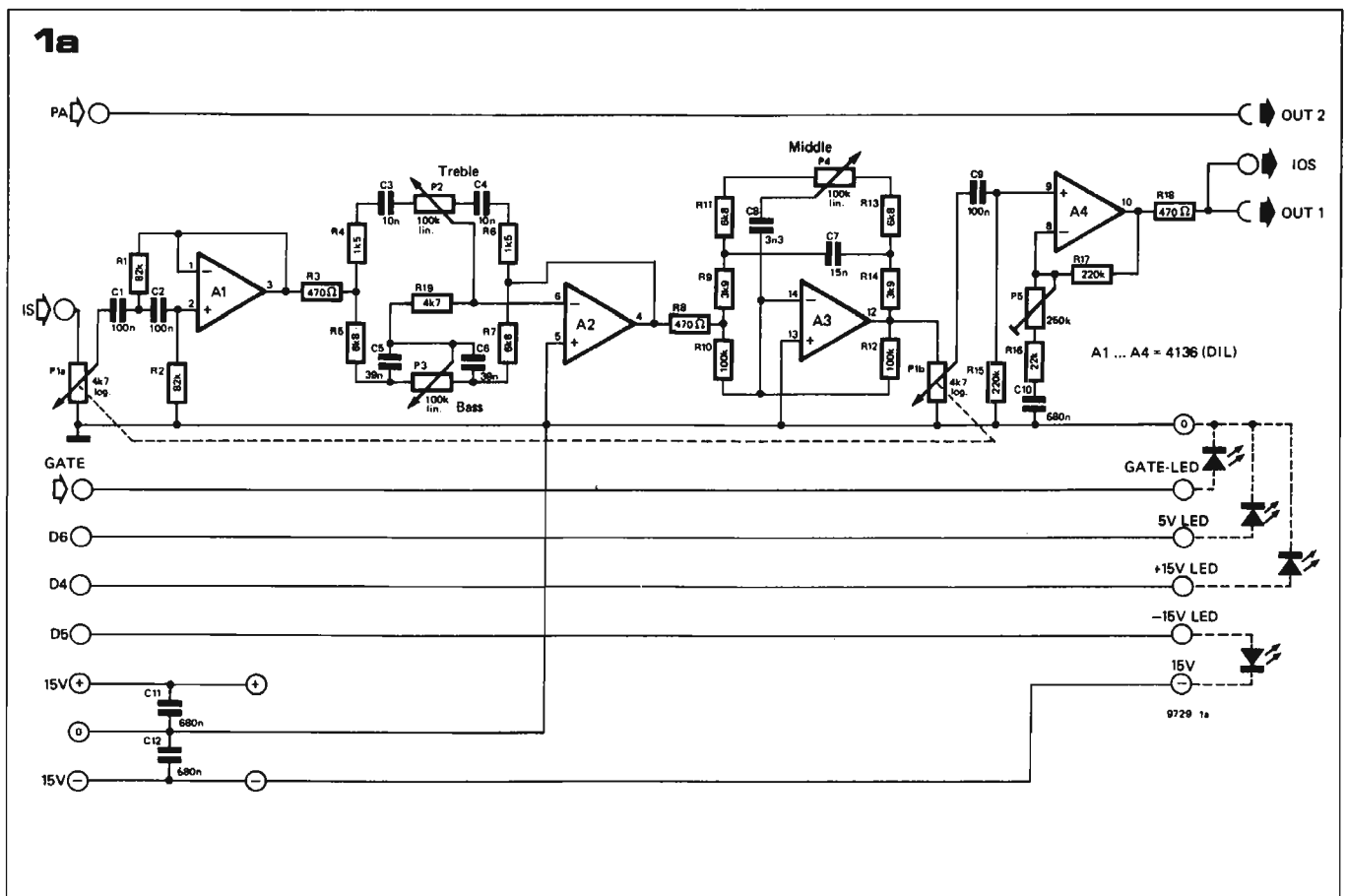

Figure 1a. Circuit diagram of the COM, which consists of a tone control/headphone amplifier and indicator LEDs for gate pulse and the three power supply voltages.

Figure 1b. Pinout of the 4136 IC.

The input signal is fed to a volume control P1a and thence to an 'anti-plop' filter built around A1. This is a 12 dB/octave highpass filter with a break frequency of around 20 Hz. It suppresses low-frequency transients and rolls off the bass response of the system to reduce 'listener fatigue' which can be caused by the low bass notes of electronic music, especially with full bass boost. By rolling off the bass response the filter also helps protect the bass drivers of the loudspeakers against excessive, very low-frequency signals. Indeed, if the synthesiser is to be used with small 'bookshelf' speakers it may be advisable to raise the turnover point of the filter to 40 Hz by changing the value of R1 and R2 to 39 k.

The treble and bass controls, built around A2, are a conventional Baxandall network. To avoid the middle control interacting with the bass and treble controls it is constructed separately around A3. The output of A3 then feeds into a second volume control P1b. The use of a ganged volume control on a single signal channel may seem a little unusual, but it does have several advantages. A volume control at the input to the COM prevents any possibility of overloading A1, whatever the signal level. On the other hand, the provision of a volume control later in the circuit allows a better signal-to-noise ratio to be maintained at low settings of the volume control, since noise (principally from A1) is attenuated along with the signal as the control is turned down. The fact that this control produces a 'double



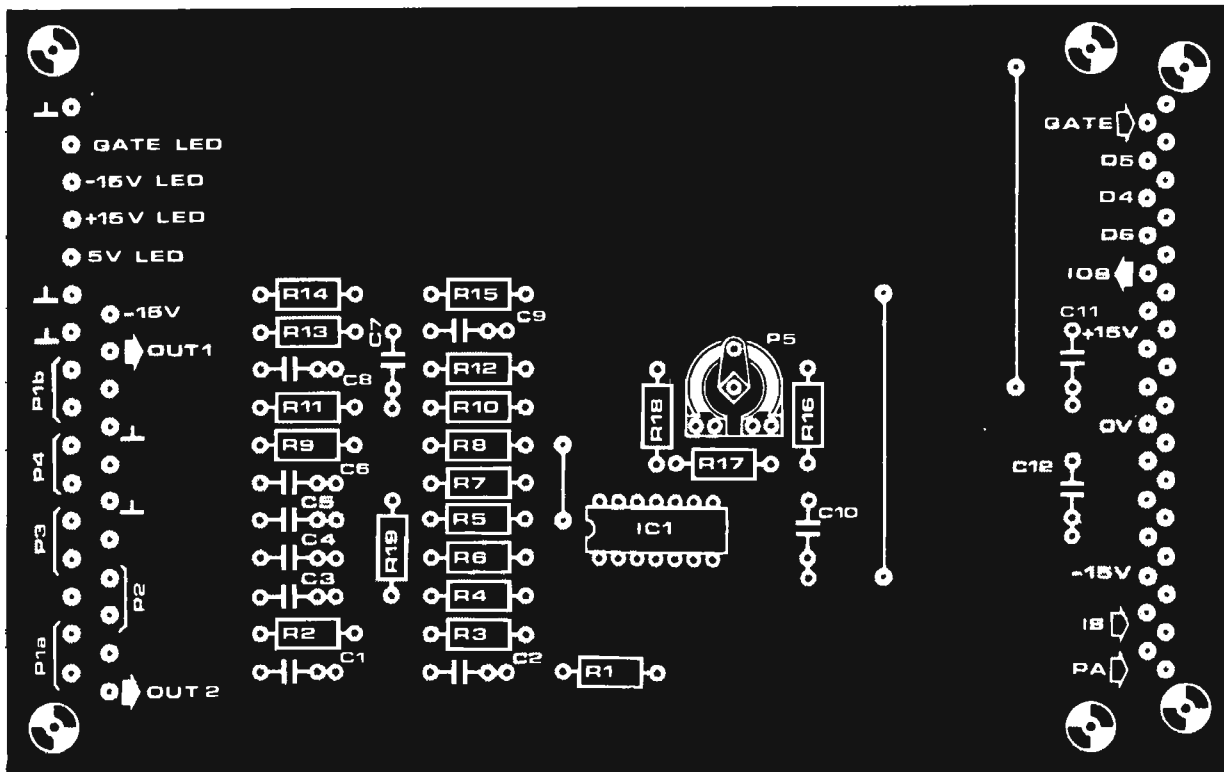
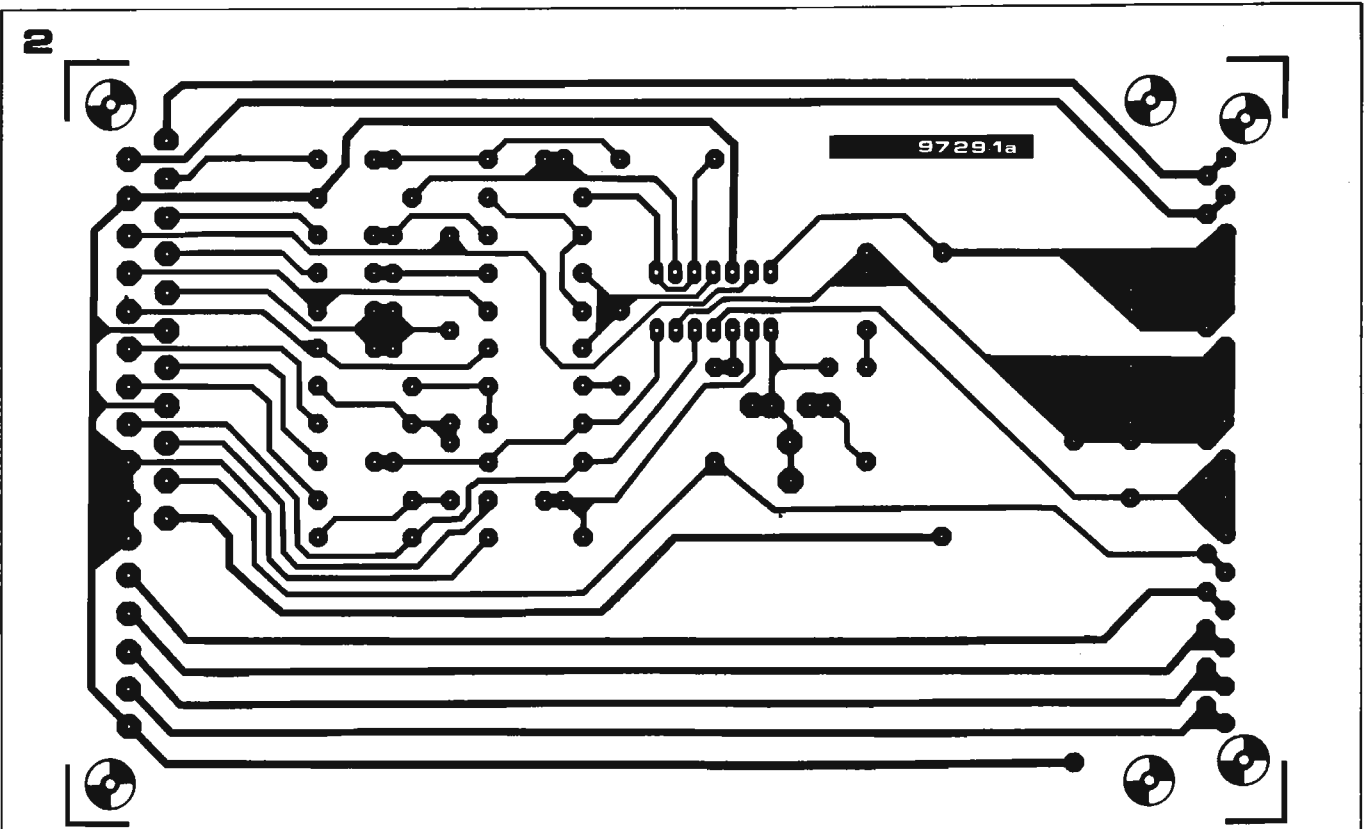

Parts list for figures 1 and 2.

- Resistors:**  
 R1, R2 = 82 k  
 R3, R8, R18 = 470 Ω  
 R4, R6 = 1k5  
 R5, R7, R11, R13 = 6k8  
 R9, R14 = 3k9  
 R10, R12 = 100 k  
 R15, R17 = 220 k  
 R16 = 22 k  
 R19 = 4k7

- Potentiometers:**  
 P1a, P1b = 4k7 log ganged pot.  
 P2, P3, P4 = 100 k lin.  
 P5 = 220... 270 k preset.

- Capacitors:**  
 C1, C2, C9 = 100 n  
 C3, C4 = 10 n  
 C5, C6 = 39 n  
 C7 = 15 n  
 C8 = 3n3  
 C10, C11, C12 = 680 n

- Semiconductors:**  
 IC1 = 4136 (DIL package) EXAR,  
 Fairchild, Raytheon or  
 Texas.

- Miscellaneous:**  
 31-way connector to DIN 41617  
 3.5 mm jack socket  
 6.3 mm jack socket  
 4 collet knobs, 13...15 mm  
 diameter, with pointer.

Figure 2. Printed circuit board and component layout of the COM (EPS 9729-1).

Figure 3. Front panel layout for the COM (EPS 9729-2).

Figure 4. Wiring diagram for the front panel mounted components.

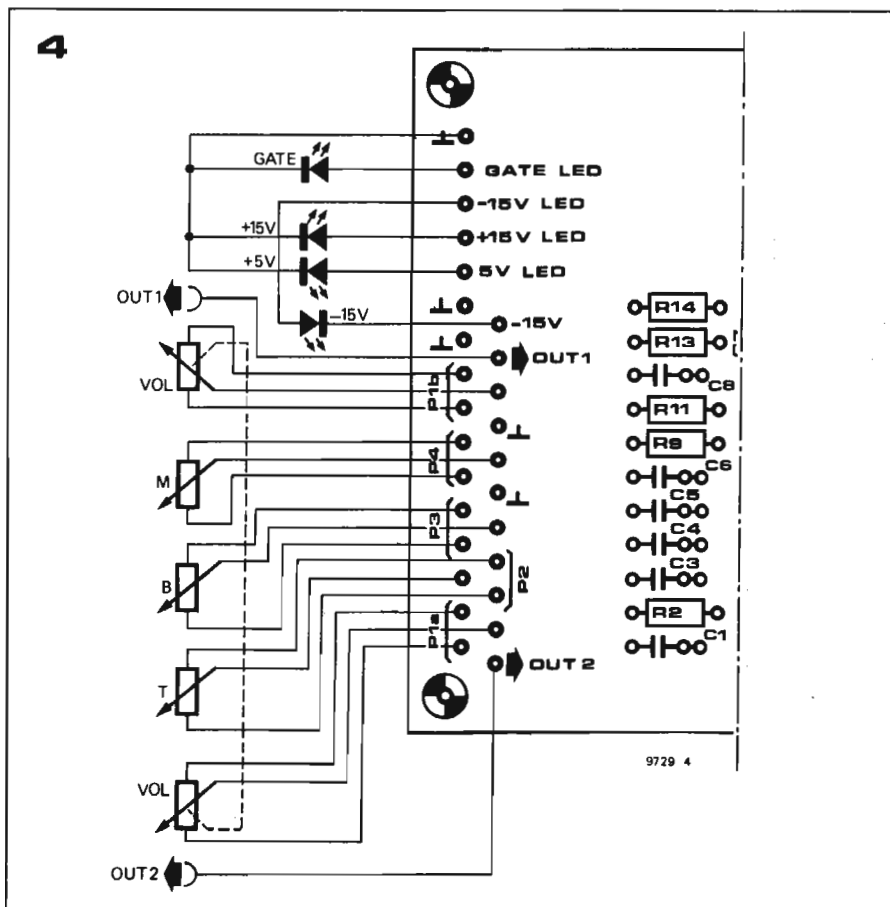

logarithmic' characteristic does not cause any inconvenience in operation. No amplifier is built into the COM as the heat generated in the output stage could cause temperature drift problems in other circuits in the system. However, the COM is provided with an internal output to a separate power amplifier, IOS. The output of the amplifier may then be brought back through the COM via the PA input connection on the COM board edge connector to a socket on the COM front panel (OUT 2). The COM output is itself also brought out to a socket on the front panel (OUT 1) into which high impedance headphones may be plugged. Note that a 6.3 mm jack socket is used for OUT 2. The four indicator LEDs also receive their power via the COM edge connector from the appropriate circuits, and are also mounted on the COM front panel.

#### Construction and testing of the COM

A printed circuit board and component layout for the COM are given in figure 2, a front panel design is given in figure 3 and wiring to front panel mounted components is shown in figure 4. Screened leads should be used for the connections to bass, middle and treble potentiometers B, M, and T.

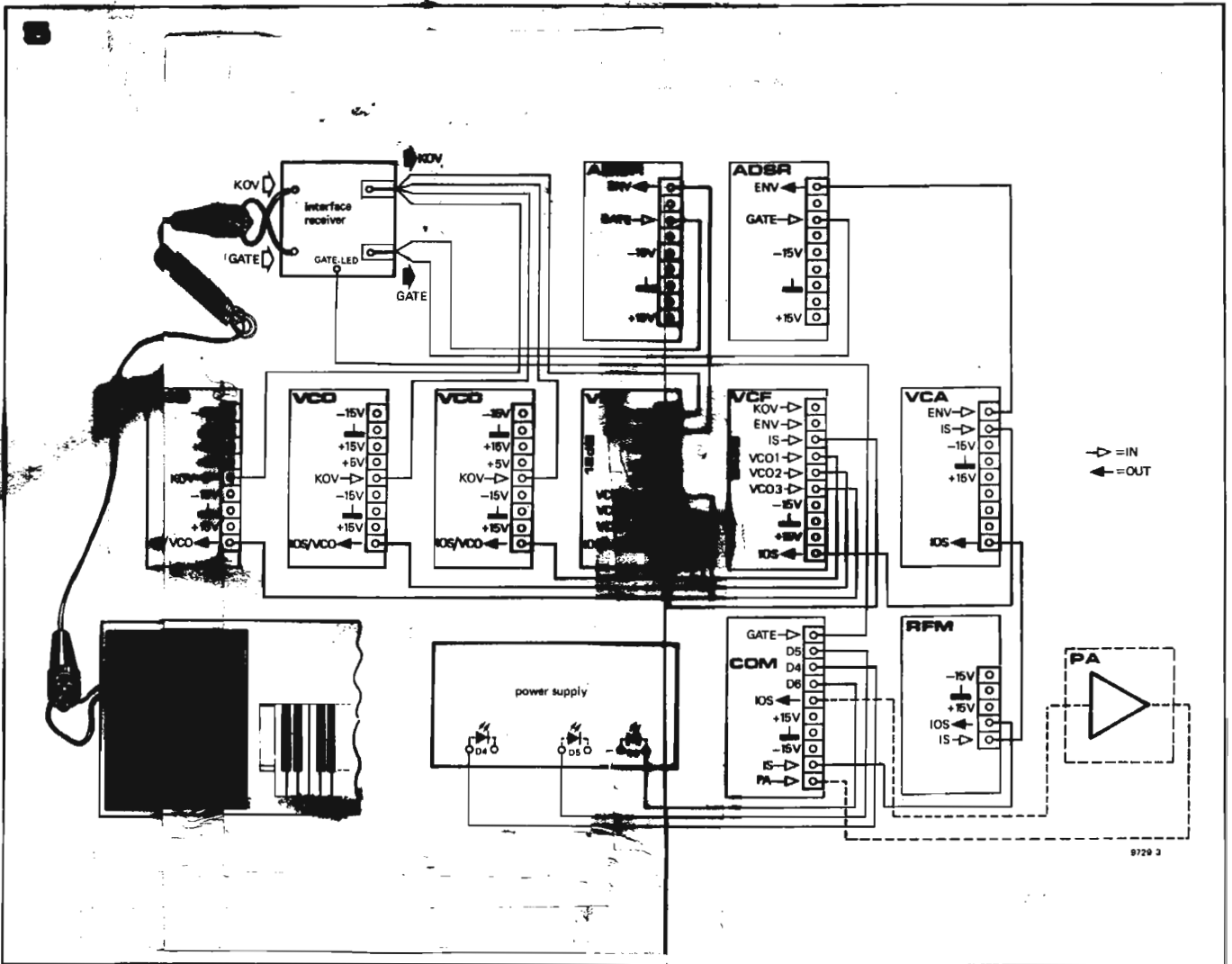

9729 3

Figure 5. Inter-module wiring for the basic Formant system. Supply voltage connections have been omitted for reasons of clarity. The LFO and noise modules have been omitted as the only hardwired connections they have are supply connections.

Figure 6. The 'gate-LED' output of the interface receiver can be simplified by mounting R30 in the 'D4' position.

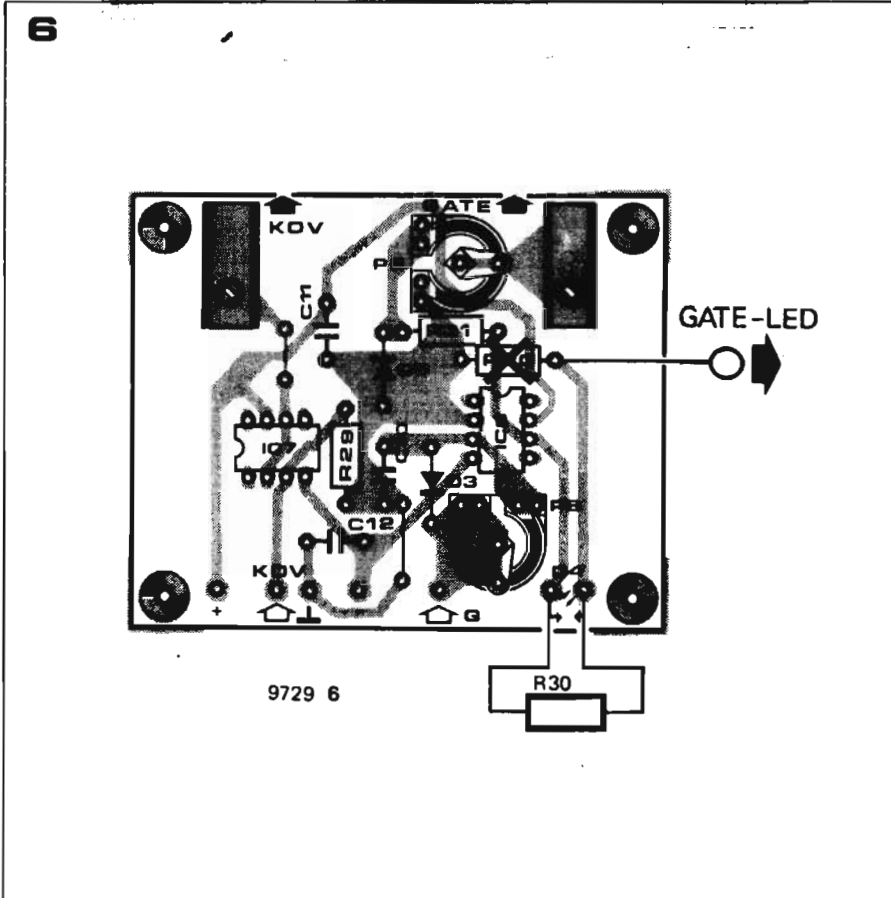

9729 6



Some readers may not wish to bring the output of a power amplifier back through the COM to output 2, since this may not be convenient especially if the synthesiser is to be used with, say, an existing hi-fi setup. In this case two options are open. Output sockets 1 and 2 can simply be connected in parallel or alternatively output socket 2 can be wired direct to input IS to provide an output signal unaffected by the tone and volume controls.

It is not intended to provide a design for an output power amplifier since several good designs have already been published in Elektor. However, a few hints on the mounting of such an amplifier will not go amiss. As mentioned earlier, the power amplifier should not be mounted in a plug-in module since it may then cause thermal problems. It should preferably be mounted at the back of the module cabinet with the output transistors mounted on heatsinks whose fins are external to the module housing. The Formant power supply is not intended to supply current for a power amplifier, so a separate power supply will be required. The mains transformer should be mounted as far away as possible from the Formant modules to reduce hum pickup (the same applies to the Formant mains transformer).

The COM can be tested by feeding in a signal from one of the VCOs and monitoring it on an oscilloscope to check that the waveform is undistorted. The gain of the COM output stage, A4, can be varied between about 1.8 and 11 by means of P5. This preset should be adjusted so that full drive of the headphones or power amplifier is obtained with the volume control turned fully up (clockwise).

### Complete wiring diagram

The interwiring between modules for the basic Formant system is given in figure 5, but readers wishing to build a more extensive system can expand this as required.

For clarity the supply wiring is not shown, but the wiring method already mentioned must be adhered to, i.e. each module should have separate supply leads from its socket back to the 'star' connection points (busbars) on the power supply module. The temptation to simplify the wiring by simply linking between the supply pins of the modules should be avoided as this will cause interaction between modules.

The 'Noise' and 'LFOs' modules are not shown in figure 5, since the supply wir-

ing is the only connection to these modules.

Again for clarity, the full pinout of each module edge connector is not shown, but the connections are shown in the correct sequence working down from the top edge of each module.

One small modification is required to the interface receiver printed circuit board (chapter 3) in order that the gate LED can be wired with only a single link. R30 on the interface receiver board is mounted in the space provided for D4 as shown in figure 6. A single wire is then connected from the lower pad to which R30 was originally connected to the appropriate pin of the COM socket. Without this modification two leads would have to be brought out to D4.

### Patchcords

Due to the hardwired interconnections between modules, Formant is perfectly playable without any of the front panel patching sockets being used. However, for effects such as vibrato and tremolo, patchcords are used to connect the outputs of the LFO module to the VCOs or VCA. These can easily be 'home-made' - see chapter 1 of Part 2.

# playing the formant

## basic control settings and musical tips on how to play the formant

Because of its inherent versatility and scope, a synthesiser is not an easy instrument to master. Even relatively experienced musicians require a certain amount of time to sufficiently familiarise themselves with a synthesiser before being able to exploit its potentialities to the full. For the beginner, the impressive array of different controls on the front panel can be extremely confusing, and his first attempts to synthesise a particular sound can all too often lead to disappointment and frustration. For this reason the following chapters are intended to provide some basic tips on how to set about playing the Formant. In addition to proving useful to Formant users, much of the advice is relevant to music synthesisers in general. In particular, the description of the resonance filter settings, which are of prime importance for the realistic simulation of conventional musical instruments, can in principle be applied to improve the sound of any electronic music instrument.

The review of basic control settings is divided into two parts: the first deals with the individual modules; how they are adjusted for satisfactory operation and how they can be used to best advantage.

The novice Formant user is thus spared the grief of coming to grips with the instrument on the basis solely of trial and error. The second part deals with combinations of basic settings used to synthesise the sounds of particular instruments. Thus, for example, the settings required to imitate the sound of a flute, trumpet, tuba, of string instruments, a piano, etc. are all

described in detail and illustrated with the aid of diagrams. As already mentioned, particular attention is paid to the role of the resonance filter module in simulating the fixed bandpass resonances or formants of individual instruments, thereby improving the realism of the resultant sound.

With the aid of the following advice, the Formant user should be able to master the basic 'palette' of tone colours offered by the synthesiser. However it is only natural that the descriptions contained in this chapter bear the 'stamp' of the author; thus the reader should not feel constrained to limit his experiments with the Formant to those described here. They should rather be regarded as an initial stimulus to the reader, who is expected to go on to discover for himself the full musical potential of the Formant.

A final tip: one of the most fruitful activities the amateur synthesiser user can do is to listen to the results obtained by some of the acknowledged masters in this field, e.g. Walter Carlos, Isao Tomita, P. Moraz, etc. This way he will obtain some idea of the amazing capabilities of a sophisticated music synthesiser.

## extending the formant

1

Before proceeding to a discussion of the basic control settings for each of the Formant modules, it is worth devoting a little attention to the equipment needed to reproduce the output of the synthesiser and the ancillary circuits which can be employed to further extend the Formant and enhance its tonal possibilities.

### Loudspeakers

Readers building a synthesiser for home use will probably wish to play the instrument through an existing hi-fi set-up, at least to begin with. If this is the case, care should be taken not to overload the loudspeakers by keeping the volume reasonably low. Hi-fi speakers are designed to handle a much more broadly distributed power spectrum than that produced by a synthesiser, and it is quite easy to damage the tweeters with a sustained high frequency note. For serious use, a purpose-designed loudspeaker should be considered. Because of their high efficiency, horn systems are to be favoured, since they can then be used in conjunction with a relatively low power amplifier. A 35-40 W amplifier when used with horn speakers is more than ample for domestic purposes. A dealer specialising in electronic music systems should be able to offer advice on a suitable choice of loudspeaker.

### Additional units

Although the Formant system so far described is a highly versatile instrument giving a performance comparable to commercial designs at a greatly reduced cost, it is nonetheless relatively unsophisticated compared to the larger commercial instruments. Fortunately, however, because of its modular conception, it is a simple matter to extend the system by adding extra VCOs, VCFs, VCAs, ADSRs, to obtain a more varied sound.

However, certain effects require the addition of completely new modules and ancillary units. One possibility which can be implemented immediately is the addition of the Elektor equaliser (January 1978) to allow presettable tailoring of the synthesiser spectrum. The equaliser p.c. board is of Eurocard format, compatible with the other Formant modules.

Phasing circuits are frequently used in synthesisers, and are particularly useful for realistic simulation of (orchestral) string tones. Another effects unit which is often used is a ring modulator. This circuit produces the sum and difference of two input frequencies at its output. The frequencies are often harmonically unrelated and strange, extremely 'unmusical' effects can be obtained.

This type of circuit is extremely useful for synthesising bell, gong, and cymbal-like sounds. A circuit for a ring modulator, suitable for use in conjunction with the Formant, was published in the March 1979 issue of Elektor.

In its basic form the range of expression available from the synthesiser is slightly limited by the fact that it is played by a keyboard. However there are various ways in which this can be remedied. The addition of a 'pitchbender' joystick, which feeds a manually controllable DC voltage to the VCOs, allows modulation of the pitch of a note by hand in much the same way that a guitarist 'pulls' the strings of his guitar.

An interesting possibility is the elimination of the keyboard by playing the synthesiser via another instrument. This is accomplished by the use of a pitch to voltage converter, which produces an output voltage proportional to the pitch of the control instrument. This in turn controls the frequency of the synthesiser VCOs. An envelope follower produces an output voltage which follows the control instrument's amplitude, and this is used to control the gain of the VCAs. The result is a synthesiser which has the dynamics of the original instrument.

Other useful additions to the synthesiser are sequencers, sample-and-hold circuits, and in particular, reverberation echo units. Sequencers are used to store (either by analogue means or digitally) a sequence of VCO/VCF control voltages. These are then 'played back' into the synthesiser to automatically generate a note sequence which can, for example, be used to provide the backing for a manually played melody.

A sample-and-hold circuit is frequently employed to take sequential samples of the instantaneous voltage of a sawtooth waveform. This sequence of voltage samples is then used to control the synthesiser to generate pseudo-random sequences of notes.

Reverberation units can be used to great advantage to enhance the 'dry' somewhat artificial character of electronically synthesised sounds by allowing the notes to die away gradually, as opposed to being cut off abruptly when a different key is pressed. Long reverberation times or echo can transform the monophonic output of a VCO into a rich 'chorus' effect.

An especially useful and inexpensive item of equipment is a foot pedal, which can be used to control the tone-shaping modules of the Formant, the VCF and VCA. With the aid of the pedal, which should provide a variable DC voltage between 0 and 5 V, a variety of modulation effects can be obtained. For example, the duty-cycle of the VCO squarewave output can be modulated by pedal so as to obtain a type of phasing effect.

It is also important to have a sufficient quantity of different coloured patchcords of various lengths. These can easily be made using flexible single-core

cable fitted with a 3.5 mm jack plug at each end. The cable is soldered to the centre contact (ball) of the plug, no earth connection being necessary as the earth return is made through the internal module wiring. In the interests of long life the patchcord wire should not be too thin, and some sort of strain relief should be used where the wire enters the plugs. To keep the front panel tidy, a good idea is to make the patchcords in different lengths, each designed for an interconnection between specific modules. Different colours of wire may also be used to simplify checking of complicated patch connections. Multiway patchcords, which are terminated at one end in several plugs, may also prove useful, allowing, e.g. the PWM inputs of several VCOs to be controlled by a single LFO output.

A high impedance pair of headphones will also prove extremely helpful, since they allow the output of individual modules to be monitored without having to reproduce them via the loudspeakers.

If an oscilloscope is available, then it is possible to follow the progress of a waveform from module to module, or to check the amplitude of a signal, etc. Such information is particularly interesting, since it permits one to actually see the envelope of signals, modulation effects, the existence of resonances, etc. All that is needed (in addition to the scope) to gain access to all the module outputs is a high impedance probe terminated in a jack plug.

Finally, having obtained a particular sound which one likes, how can the corresponding control settings be preserved for future reference? — a point which many Formant users have found to be a problem. One solution is the sketch of all the various Formant modules included at the end of this book. This can be photocopied and used for making a note of the control settings for each module.

## control settings of individual formant modules

2

### VCOs

#### Main characteristics of the VCOs

The Formant VCOs are electronic tone generators whose pitch can be varied over the range of audible frequencies. Assuming that they have been correctly set up during construction (V/octave characteristic and high frequency tracking), the VCOs should be accurately tuned and capable of tracking one another over a large number of octaves. Although the temperature drift of the VCOs should be so small as to be negli-

1

**COM**

11

10

**VCO**

3

14

1

2

**VCO**

3

14

1

2

**VCO**

3

14

1

2

**VCF**

4

7

5

8

6

**DUAL VCA**

9

10

**INTERFACE PORTAMENTO**

12

15

13

9916-1

Figure 1. Tuning the VCOs.

gible, the Formant should nonetheless be protected against sudden or excessive variations in temperature. Suitably positioned ventilation holes in the case of the instrument should help to reduce temperature fluctuations (and drift) to a minimum.

The approximate pitch of each VCO can be rapidly adjusted (over an extremely wide range) by means of the COARSE tuning control, whilst exact tuning is obtained with the aid of the FINE control.

With a choice of five different waveforms from each VCO (sinewave, sawtooth, spaced sawtooth, triangle, and pulse-width modulated squarewave) the range of basic tone colours for subsequent synthesis is extremely varied. The waveforms can be rapidly selected by means of toggle switches, and fed in any combination to the VCO output.

The output level control (OUT) determines the relative proportions of each VCO output fed to the VCFs. The capabilities of the VCOs are further enhanced by provision of an external control voltage input (ECV), a frequency modulation input (FM) for vibrato etc., and an input for pulse width modulation of the squarewave by external control voltages. The depth of pulse width modulation can also be varied by hand.

### Tuning the VCOs

This section describes the tuning procedure for the VCOs which should be followed exactly. VCOs which are not exactly in tune sound 'rough' and dissonant, and are musically of little use. If in spite of carefully carrying out the procedure described here, the VCOs should continue to sound unsatisfactory, then the V/octave and high frequency tracking pots in each of the VCOs should be readjusted.

A 'bright' waveform, such as e.g. the sawtooth, which is rich in all harmonics, is best suited for tuning the VCOs, since beat notes are then particularly prominent. Before commencing the tuning procedure the other Formant modules must be set so that the output signals of the VCOs are fed in unchanged form to the power amplifier (figure 1).

First of all the output level controls are set to maximum (1) and the desired waveform, e.g. sawtooth, is selected (2). The VCO input is then switched to KOV - the keyboard output voltage (3). To ensure that the VCF(s) have no effect upon the VCO signals, the ENV and Q controls of the filter(s) are set to 0 (4) and (5), whilst the lowpass mode is selected (6) and the turnover frequency of the filter(s) is set to maximum (7). If the RFM is present it should be switched to 'bypass'. The output level control of the filter(s) is likewise set to maximum (8). The output of the VCOs is now passed unaltered by the VCF(s).

To ensure that the VCA likewise has no effect on the VCO signals, the toggle switch should be set to OFF (9) and the GAIN control set to maximum (10). The tonal character and volume of the VCO signal is set by means of the bass, midrange, treble and volume controls of the COM module (11). Finally, it is best to eliminate the effect of the COARSE offset control on the INTERFACE module by switching the latter out of circuit (12).

Before starting the tuning procedure proper, it is important to note that one should always start with the key on the extreme right (i.e. the 'highest' key) of the keyboard (13). In this way it is possible to ensure satisfactory tracking of the VCOs. Whilst the top key is pressed, the pitch of the VCOs is adjusted using the COARSE and FINE controls (14). If two or more VCOs are to be tuned to the same pitch, the FINE control should be adjusted until no further beat notes can be distinguished or else until the frequency of the beat notes is as low as possible. Of course it is also possible to deliberately mistune the VCOs very slightly so as to obtain phasing and chorus effects. The resultant sound is then less sterile or artificial.

Many users experience difficulties when attempting to tune three or more VCOs to obtain complex chords. This can be done as follows: First of all the lowest note in the chord is set up on one of the VCOs (the others are switched out). In the case of a simple major chord such as 'C'-'E'-'G', this would be 'C'. Once the 'C' key has been tuned, the key corresponding to 'E' should be pressed, and the pitch of the first VCO noted. The second VCO is then tuned by switching out the first VCO, pressing key 'C', and adjusting the COARSE control until the pitch of the signal is the same as that obtained from key 'E' with the first VCO. The third VCO is tuned for 'G' in exactly the same way.

The second VCO is switched out and the pitch of the key corresponding to 'G' on the first VCO is noted. Upon switching to VCO 3 key 'C' is tuned by memory to 'G' of the first VCO.

This method is initially somewhat time consuming, and may need to be repeated several times, until the VCOs are tuned sufficiently accurately. Finally, the VCOs can be 'fine-tuned' to obtain the

desired degree of phasing or chorus effect.

A useful aid for tuning chords is an electronic tone generator based on a crystal-controlled oscillator. Programmable dividers are used to provide a series of reference frequencies. The circuit of a suitable tuner was published in *Elektor* 15/16 (July/August 1976 - see also *Elektor* 17, p 9-57). The reference signals can be mixed with the VCO signals via the external input of the VCF or VCA, whereupon the VCO is zero beat tuned.

Of course the user is not constrained to tune the Formant in the equally tempered tonic scale, but is free to choose whichever scale he wishes.

A few additional remarks on chords:

As already mentioned, tuning several VCOs to roughly the same pitch produces a phasing effect which lends the resultant sound a harmonious, 'shimmering' quality. If the higher frequencies are filtered out using the VCF in the lowpass mode, a deep 'rolling' bass sound is obtained, similar to that of a church organ or grand piano. Passing the high frequencies and playing on the higher notes produces violin-like, or 'metallic' sounds. Tuning the VCOs at intervals of an octave causes the individual notes to merge together into an extremely rich overall sound, which, due to the large number of different frequencies it contains, has a great deal of 'body'. Interesting effects can be obtained by tuning VCOs several octaves apart and using different proportions of VCO signals and different waveforms for each VCO. This extends the range of basic tone colours available for subsequent synthesis. In certain instances simple major chords can sound extremely impressive, such as e.g. simulating fanfares of brass instruments. On the other hand, major chords can tend to sound rather monotonous and 'sickly-sweet', since the monophonic keyboard does not permit their resolution through chord changes. This is a problem with all chords which have a fixed, well-defined character. Because of the lack of chord changes they can rapidly become monotonous. One solution is to use a second, independent voice in the form of e.g. a MINI-FORMANT.

Minor chords, however, are particularly attractive on the Formant, since (as is the case with a guitar or piano) extremely complex phasing patterns are developed. The sound often benefits musically from using the lowpass filter to slightly attenuate the higher harmonics of the signal.

### Pulse width modulation (PWM)

With the Formant VCOs the width of the squarewave output can be varied both by hand (using the PW control) and by means of an external modulation signal. In the latter case the modulation depth can be set by means of the control knob situated beneath the PWM input socket.

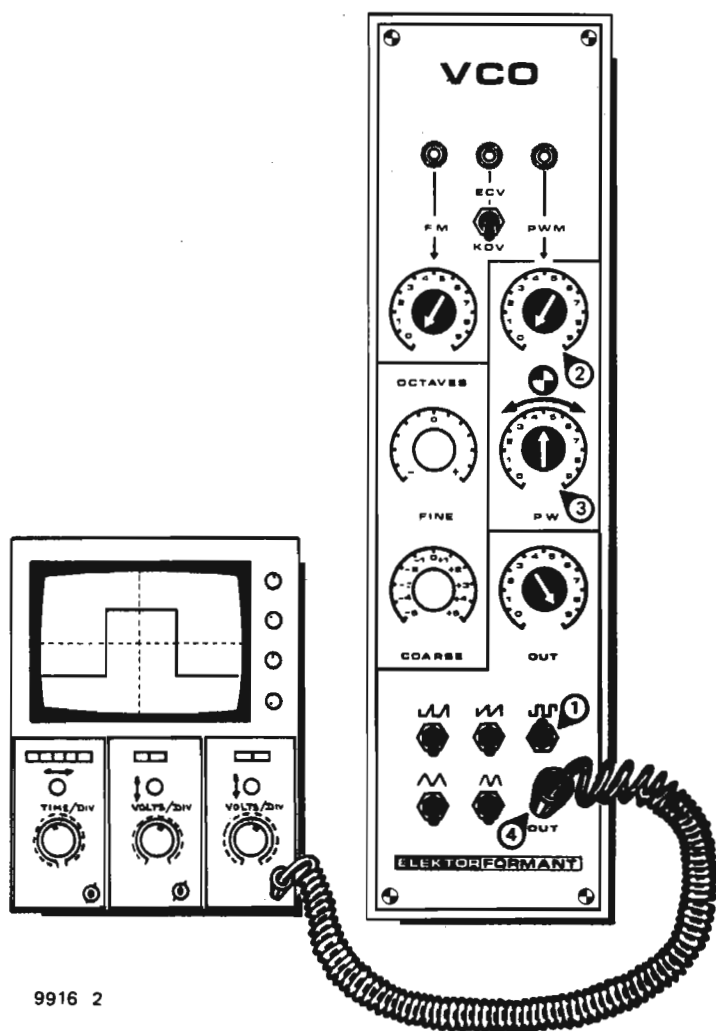

9916 2

To hear the effect of PWM, use only one VCO switched, naturally enough, to the squarewave output (see figure 2), and start with the modulation depth control (2) set to zero. Gradually increase the pulse width, from zero, by turning the PW control clockwise (3). The sound of the squarewave signal will change from a bright and rather 'thin' character to a point where it is distinctly hollow and clarinetlike. In this position the modulation depth is 50%, i.e. the squarewave has a 50% duty cycle. If one continues to turn the PW control to the right, the sound again becomes increasingly brighter and thinner. The change in the squarewave can be seen quite clearly if one connects the VCO output to a scope (4). Filtered squarewaves with a roughly symmetrical mark space ratio are useful for the simulation of a number of woodwind instruments and for piano-like sounds. Triangle waveforms are best suited as low frequency PWM signals. The resulting effect is similar to the phasing obtained when two or more VCOs are tuned to the same pitch.

Before looking at the use of the LFO module for pulse width modulation, it is worth first mentioning a couple of other interesting possibilities for external control signals.

If the output of an ADSR envelope

generator is connected to the PWM input, the result is *dynamic pulse width modulation*, which varies during the course of each note. Depending upon the character of the envelope contour, extremely unusual, seemingly distorted sounds can be obtained, as well as sounds which gradually decay with a slow and pleasant phasing effect. The amplitude of the ADSR modulation signal is set by means of the modulation depth control directly underneath the PWM input socket (2), whilst the duty-cycle offset of the squarewave, i.e. at what mark-space ratio the pulse width modulation begins, is set by means of the PW control (3).

Another possible way of modulating the pulse width of the squarewave is to use the control pedal, which depending upon its position provides an output voltage of between 0 and 5 V. The latter is fed, like the ADSR output, to the PWM input socket. Once again, the initial mark-space ratio and the amplitude of the modulation signal are set by the PW and pulse modulation depth controls respectively. With the aid of multiway patchcords the pedal can be used to modulate several VCOs simultaneously.

Now to using the PWM input in conjunction with an LFO (figure 3). In

order to obtain phasing over the entire range of modulation settings, the VCO should be set up as follows. The triangle output of the LFO is connected to the PWM input of the VCO (1). The modulation depth control is set to zero (2), and the initial mark-space ratio of the squarewave is set to 50% (3). At this stage the squarewave should sound hollow and clarinet-like. It may be necessary to adjust the initial pulse width slightly to obtain the desired effect. The LFO frequency should be fairly high, say approximately 1 Hz.

If the modulation depth control (2) is now turned fully clockwise to its right hand stop, on positive and negative peaks of the modulation signal the mark-space ratio of the squarewave will be 0 and 100%, i.e. the signal will be punctuated with regular gaps. To eliminate this effect the modulation depth should be reduced (2) until there are no longer any audible glitches in the output signal. Effective pulse width modulation can now be obtained for any intensity of modulation signal, and the user is free to vary the frequency of the LFO signal as desired. Best results are obtained if fairly slow modulation rates are used, since the frequency of beat notes is then low — of the same order as those produced when tuning several VCOs to approximately the same pitch.

In the case of LFO modulation, it is recommended using a separate LFO output for each VCO. By slightly varying the modulation frequency of each LFO it is possible to produce extremely complex phasing patterns when the squarewave signals are mixed together. The effect is that of multiple sound sources, i.e. as if there were more than three VCOs present. It is by independently modulating several VCOs in this way that one is able to obtain some of the most impressive orchestral effects (string ensemble etc.) from the Formant.

### Ring modulation using PWM

In the March 1979 issue of *Elektron* a circuit for a ring modulator, which could be used in conjunction with Formant, was published. However it is also possible to obtain sounds containing a large number of intermodulation products simply by using PWM between two or more VCOs. The squarewave output of one VCO is fed to the PWM input of another (see figure 4). The OUT control of VCO 2 is turned right down (2), whilst the two PW controls on VCO 1 are set as for LFO modulation signals. The settings for these controls are not particularly critical in this case. The OUT control of VCO 1 is turned up full (3).

Depending upon the frequency settings of the two VCOs, typical ring modulator effects (reminiscent e.g. of the noise from short wave radios) are obtained at the output of VCO 1. Certain settings produce the basic timbre of gong and bell-like sounds, which are characterised by unrelated harmonic components.

3

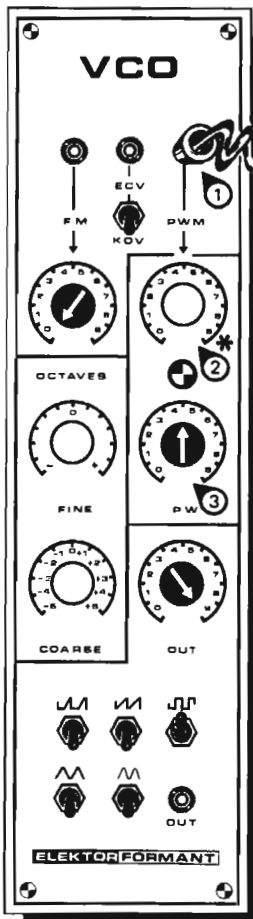
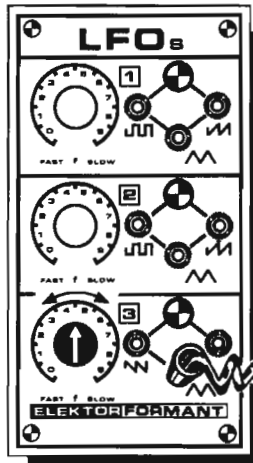

9916. 3

\* see text

### VCO Waveforms

A detailed description of the role of different waveforms in synthesising the tone colour of particular instruments is contained in chapter 3. At this stage suffice it to note that, thanks to the internal patching between VCOs, it is possible to switch between the different waveforms and mix the outputs together extremely rapidly and in a wide variety of different proportions. It is worth while experimenting with as many different combinations of waveforms as possible. With a little practice it is not difficult to familiarise oneself with the musical character of individual VCO waveforms. Sawtooth and spaced sawtooth, which are rich in both odd and even harmonics, have a 'bright' character, which renders them suitable for the imitation of brass and string instruments. In the case of the spaced sawtooth, the upper harmonics are particularly pronounced, so that they resemble the higher-pitched brass instruments such as the cornet. Filtering out the higher frequencies of a sawtooth around the middle octaves produces a more mellow, flute-like sound, whilst filtering of the fundamental gives a timbre similar to that of the oboe. Symmetrical waveforms, such as the squarewave and triangle, contain only

odd harmonics, and are characterised by a 'hollow' sound. The basic squarewave resembles a bright, strongly played clarinet. Varying the pulse-width (duty-cycle) of the squarewave so that the waveform is no longer symmetrical has the effect of introducing the even-numbered harmonics and producing a more 'reedy' timbre. Rectangular waveforms are also employed for piano sounds.

The triangle, which is also a symmetrical waveform, has a smooth mellow character, similar to that of a flute. This is due to the fact that the higher harmonics are of a very low amplitude, much lower than those of the squarewave. The sinewave, which in principle has no harmonic content apart from the fundamental, is even smoother still. However the relatively high harmonic distortion of the sinewave ensures that it does not sound completely expressionless and bland.

By judicious mixing of different combinations of waveforms and selective (resonance) filtering, it is possible to produce an enormous variety of different sounds, each with a unique timbre.

### Frequency modulation

Each of the VCO front panels is provided with an 'FM' input socket for frequency

4

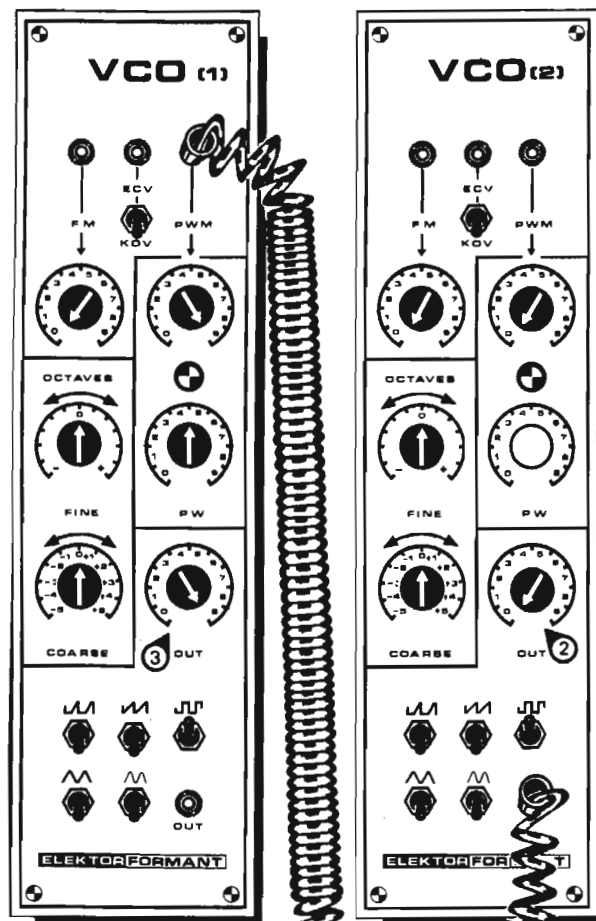

9916 4

Figure 2. Manual adjustment of pulse width.

Figure 3. Pulse width modulation using an LFO.

Figure 4. Ring modulator effects using PWM.



modulation of the VCO by an external signal. The control situated directly beneath the FM socket determines the modulation depth, i.e. the maximum frequency deviation. As is the case with PWM, various different modulation signals can be used, the most obvious being the LFO outputs.

#### Vibrato

This is the simplest and most common form of frequency modulation. The triangle output of an LFO is fed to the FM input of the VCO, and the modulation depth is gradually increased until low level modulation occurs. To obtain a pleasing vibrato effect, the frequency of the modulation signal will vary (between roughly 1 and 10 Hz) depending upon the type of instrument being simulated. Normally it will be in the region of 5 Hz.

Musically, vibrato lends the resultant sound a 'singing' character, which is particularly effective when simulating stringed instruments. If vibrato is applied to several VCOs using separate modulation signals, rich choral and orchestral effects can be obtained. The variety of vibrato effects can be rendered even more expressive by gradually varying the modulation depth as one is playing.

#### 'Deep' FM

If the modulation depth is increased (still with a triangular modulation signal), siren-like effects, sweeping up and down the entire range of audio frequencies, are obtained. Depending upon the waveform and frequency of the LFO signal, as well as the settings of the VCO controls, an amazing variety of different sounds and effects - often highly artificial and electronic in character - can be produced. It is also worthwhile experimenting with squarewave modulation signals to several VCOs. It is sometimes possible to generate rhythmic tonal structures which can be played from the keyboard.

#### Cross modulation

Purely 'electronic', 'shortwave static' type noises can be obtained by cross-coupling the outputs and FM inputs of two VCOs. By experimenting with different settings of the FM, OUT and COARSE controls of both VCOs, a variety of 'atmospheric' effects can be obtained.

#### ECV/KOV

With the ECV/KOV switch in the KOV position, the pitch of the VCO signal is determined by the output voltage of the keyboard interface receiver, i.e. by whichever key is depressed. If this switch is set to the ECV position, however, the keyboard output voltage ceases to have any effect upon the VCO signal. The frequency of the VCO will instead be determined by the voltage fed to the external control voltage socket above the ECV/KOV switch. The type of control voltage which might be fed to this socket is e.g. the output of a

sequencer, or of a second keyboard (with its own interface).

If the switch is set to ECV, but no control voltage is fed to the socket, the VCO can be used as an audio oscillator, with which the volts per octave characteristic and high frequency tracking of the other VCOs can be checked. The adjustment procedure is identical to that described at the end of Chapter 5 in Part 1.

#### Interface

The COARSE and FINE tuning controls on the keyboard interface provide a variable DC offset voltage which allows the compass of the synthesiser to be extended beyond that of the keyboard, and provides the possibility of chord transposition. The COARSE control can be switched in and out by means of the ON/OFF switch, so that a certain transposition can be 'programmed' on the COARSE control and switched in when desired. With the aid of the COARSE and FINE controls the synthesiser can be easily tuned to the register of any desired musical instrument.

The PORTAMENTO control varies the difference in pitch between successive keys, permitting *glissando* effects, i.e. a continuous glide from one tone to

another. Subtle variations of *glissando* can be obtained by varying the portamento with the left hand whilst playing the keyboard with the right hand. The remarks concerning the use of FM inputs and controls on the VCOs also apply to the interface circuit, bearing in mind that a signal fed to the FM input of the latter will affect all the VCOs and the VCF tracking filters, so that a form of 'master vibrato' is obtained.

#### VCFs and RFM

##### Main characteristics of the VCFs

In addition to the resonance filter module (RFM), the complete Formant system contains two separate voltage controlled filters (12 dB per octave and 24 dB per octave). The combined effect of the three filters gives the Formant great versatility, and makes it possible to obtain a wider and more detailed range of tone colours than is the case with most synthesisers of comparable size. The two VCFs are most commonly employed as tracking filters controlled by an envelope shaper (i.e. the ADSR), so as to provide dynamic variation in the harmonic content of a note. Due to the less severe filtering of higher harmonics, the 12 dB VCF is suited to

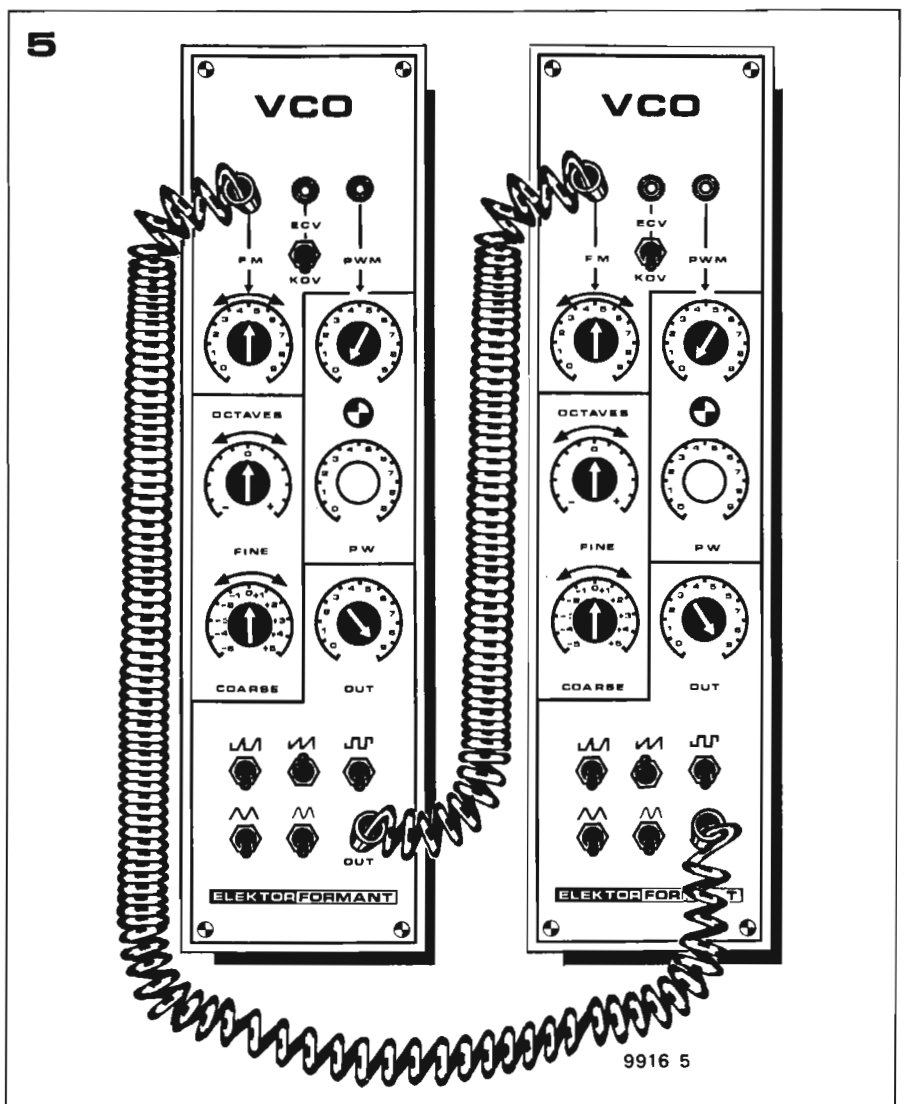



producing bright, 'transparent' sounds, whilst the steeper roll-off of the 24 dB VCF gives a fuller, more 'symphonic' sound which often has a more natural, less 'electronic' harmonic structure.

Both VCFs can also be used as static filters, simply modifying the tonal character of a VCO waveform to obtain the timbre of a particular instrument. For example either VCF can be used in the lowpass mode to filter out the upper harmonics of a squarewave and so simulate a flute-like tone.

Used in conjunction, precise tailoring of tonal characteristics is possible. Some typical effects which can be obtained using the two VCFs were described in the introduction to the 24 dB VCF module (see chapter 7, Part 1).

Since it can operate in the bandpass mode, the 12 dB VCF can also be used to complement the resonance filter, when simulating the *formant bands* of particular instruments. Indeed, in the absence of a resonance filter module, the 12 dB VCF can provide the resonance filtering necessary for realistic imitation of the voicing of conventional musical instruments. The turnover frequency of both filters can be varied over virtually the entire audio range with the aid of the OCTAVES control. The lowest turnover frequency is something below

15 Hz, which is sufficient to effectively block the VCO output when in the lowpass mode.

Both VCFs are normally patched internally to an ADSR. The amplitude of the envelope control voltage, i.e. the extent to which the cut-off frequency of the filter is shifted up and down, can be varied by means of the ENV control. Both filters also have a Q control, with the aid of which the selectivity of the filter can be adjusted. The turnover frequency of the VCFs can also be modulated by means of a low frequency signal fed to the TM (tone colour modulation) input socket, the modulation depth being set by the TM control. Finally, the external input socket (ES) and control allow the centre frequency/turnover point of the filter to be varied by a foot pedal, or some other external control voltage.

In the case of the 12 dB VCF, three toggle switches are used to select between the four available filter modes, 12 dB highpass, 12 dB lowpass, 6 dB bandpass and notch (the latter is provided by a combination of the highpass and lowpass functions). Unusual filter responses (e.g. elliptical response curves) can be obtained by experimenting with various combinations of switch positions and Q settings. In the case of the 24 dB VCF, toggle switches are used to select between highpass and lowpass modes and between different filter slopes (6, 12, 18 or 24 dB per octave).

**Using the VCFs as tracking filters**

As explained, the VCFs can be used as tracking filters, to provide dynamic variations in harmonic content during a particular note. The starting point are the basic control settings described in the tuning procedure for the VCOs, where the VCF initially has no effect upon the VCO output signal. The ECV/KOV switch is set to KOV (1), the filter switched to the lowpass mode (2), and the TM (3), ES (4) and Q (6) controls turned fully anticlockwise (see

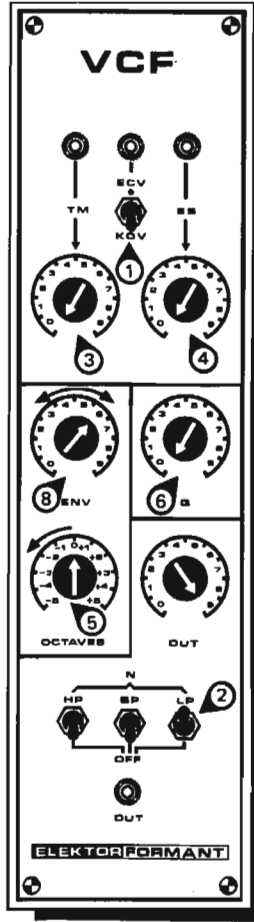
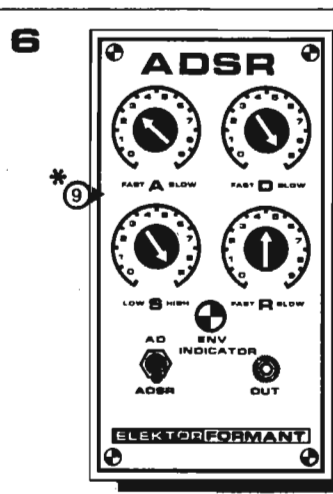
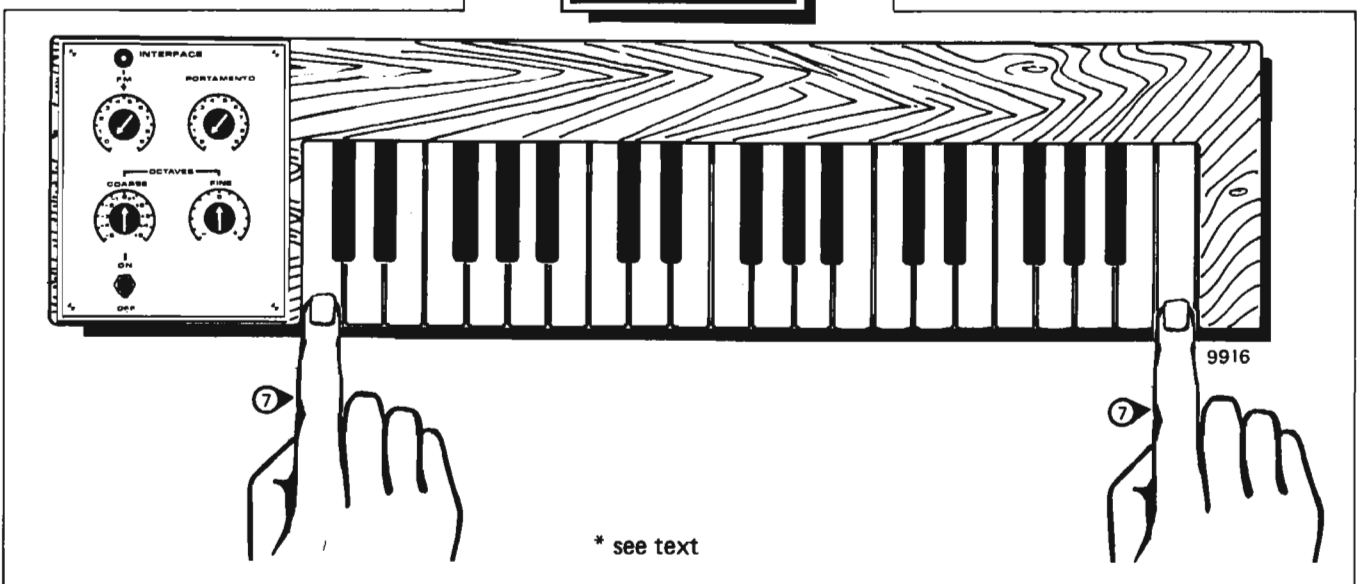

Figure 5. Cross modulation.

Figure 6. Setting up the VCF for use as a tracking filter.



\* see text

figure 6). By slowly turning the OCTAVES control to the left (5), the turnover frequency of the filter is gradually lowered, and the tone colour of the VCOs should grow increasingly 'darker', as more and more of the higher harmonics in the signal are filtered out. Eventually, a point will be reached where the VCO signal is no longer audible. By pressing the top and bottom keys on the keyboard (7) one should check that the filter effectively blocks the VCO output signal regardless of the pitch of the note. It may prove necessary to readjust the OCTAVES control slightly at this stage. If a satisfactory result is still not obtained, the volts/octave characteristic of the filter needs to be readjusted. When the above procedure is completed, the VCF will 'open' (i.e. its turnover frequency will increase to pass more of the VCO signal) and 'close' (the turnover frequency falls to filter out the VCO signal) when a key is struck and released at a rate determined by the envelope contour of the ADSR.

Whilst experimenting with different keys, the ENV control on the VCF (8) is now gradually turned up (clockwise). The changes in harmonic content as the envelope control voltage is increased should be audible as different tone colours.

The timbre or tone colour of each note should grow brighter as the amplitude of the envelope voltage is increased and more of the harmonics are passed. With the ENV control turned fully clockwise a 'brilliant', strident tone is obtained, which may sound discordant. In the case of the 24 dB VCF, the level of the envelope control voltage is quite critical, since this filter is capable of very fine discriminations in harmonic content and tone colour. With percussive AD contours (rapid attack, slow decay) it is particularly important that the ENV control is not set too high, otherwise the VCF 'overshoots', and the peak of the AD curve is not reproduced in the dynamic harmonic content of the note. The next step is to experiment with different ADSR envelope contours. With, for example, a sawtooth VCO waveform, it is possible to vary the sound from that of brass to string instruments; with additional waveforms the typical tonal character of clarinet, flute and other woodwind instruments can be simulated, whilst if the Q of the filter is increased, Wa-Wa effects and unusual speech like sounds are produced. For natural sounding tone colours the Q control should be turned almost fully anticlockwise.

When used as a tracking filter the VCF is almost always best switched to the lowpass mode. However interesting effects can be obtained by selecting the highpass response and 'inverting' the envelope contour, whilst phaser like effects can be produced by selecting the notch response in the case of the 12 dB VCF.

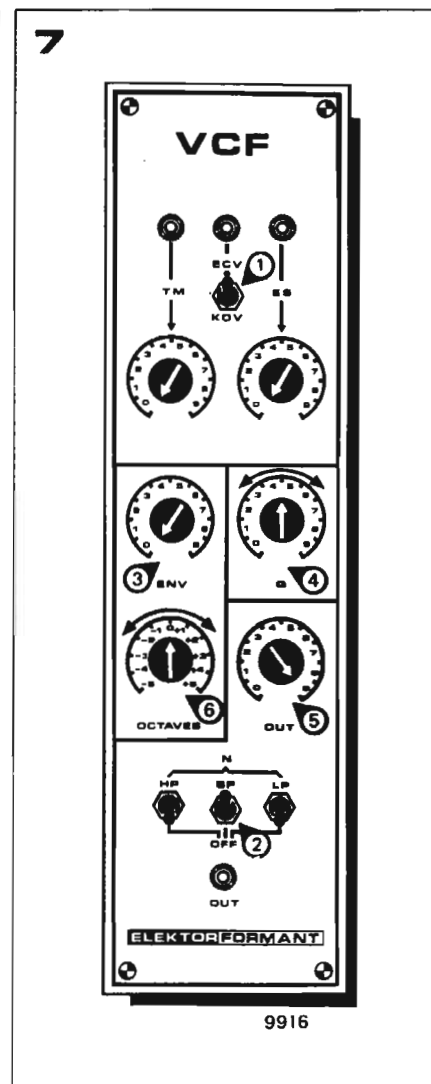

### Using a VCF as resonance filter

In the absence of a resonance filter module, it is possible to use the 12 dB VCF to tailor the static harmonic content of a note so as to reproduce the *formants* (fixed bandpass resonances) of mechanical tone generators such as brass, woodwind and string instruments. As has already been explained, this allows the voicing or timbre of these conventional instruments to be simulated with a much greater degree of realism.

When used as a resonance filter (see figure 7) the ECV/KOV switch should be set to ECV (1), and the bandpass function selected (2). The ENV control is turned right down to zero (3), whilst the Q control is set to the mid-position (4). As was the case when tuning the VCOs and experimenting with the VCF as a tracking filter, a 'bright' waveform which is rich in harmonics (e.g. the sawtooth) should be selected. The OUT control should be turned up full (5), so that the resulting sounds can be heard clearly. The frequency of the VCO signal should be set at roughly 200 Hz. If the OCTAVES control of the VCF is now turned gradually from left to right, the effect of variations in the centre frequency of the bandpass response should be audible. The results should be identical to those obtained with the

Figure 7. Setting up the VCF for use as a resonance filter.

Figure 8. The 12 dB VCF used to provide pedal controlled Wa-Wa.

resonance filter module (see chapter 8 Part 1). Initially 'dark' sounding tones are produced; then as the centre frequency of the filter is increased, one by one the various vowel sounds can be heard ('u', 'o', 'e', 'i' and 'a' should each be distinguishable), until at high centre frequencies, sharp, reedy sounds are produced. These vowel-like sounds are obtained over the frequency range of roughly 100 to 2000 Hz, and the majority of bandpass resonances of musical importance lie within this region. A table listing the main fixed resonances of the most common conventional musical instruments along with a rough guide to the most appropriate type of VCO waveform, was given in Part 1, in the chapter on the RFM. The greater the Q of the filter, the more pronounced are the variations in tone colour, since the formant bands which are being enhanced are then even narrower. The lower the Q, the less noticeable the effect of resonance filtering.

How resonance filtering can be employed to simulate the timbre of specific instruments is described in greater detail in chapter 3.

### Other filter settings

#### Modulated bandpass filter

The above settings for the resonance filter mode are left untouched, whilst a very low frequency triangle waveform is fed from one of the LFOs to the TM input. The TM control is set to roughly the mid-position. The OCTAVES and TM controls should together be adjusted until a suitable modulation depth (i.e. range of frequencies over which the centre frequency of the filter is modulated) is obtained. The intensity of the resonance filtering is then set by means of the Q control. The continual variations in tone colour which result, produce a sound which is extremely pleasant, and somewhat reminiscent of phasing.

#### Pedal controlled Wa-Wa

With the VCF in the basic resonance filter mode it can be used to provide pedal controlled Wa-Wa. The pedal, which can easily be constructed, should provide a 0 to 5 V DC supply, which is

8

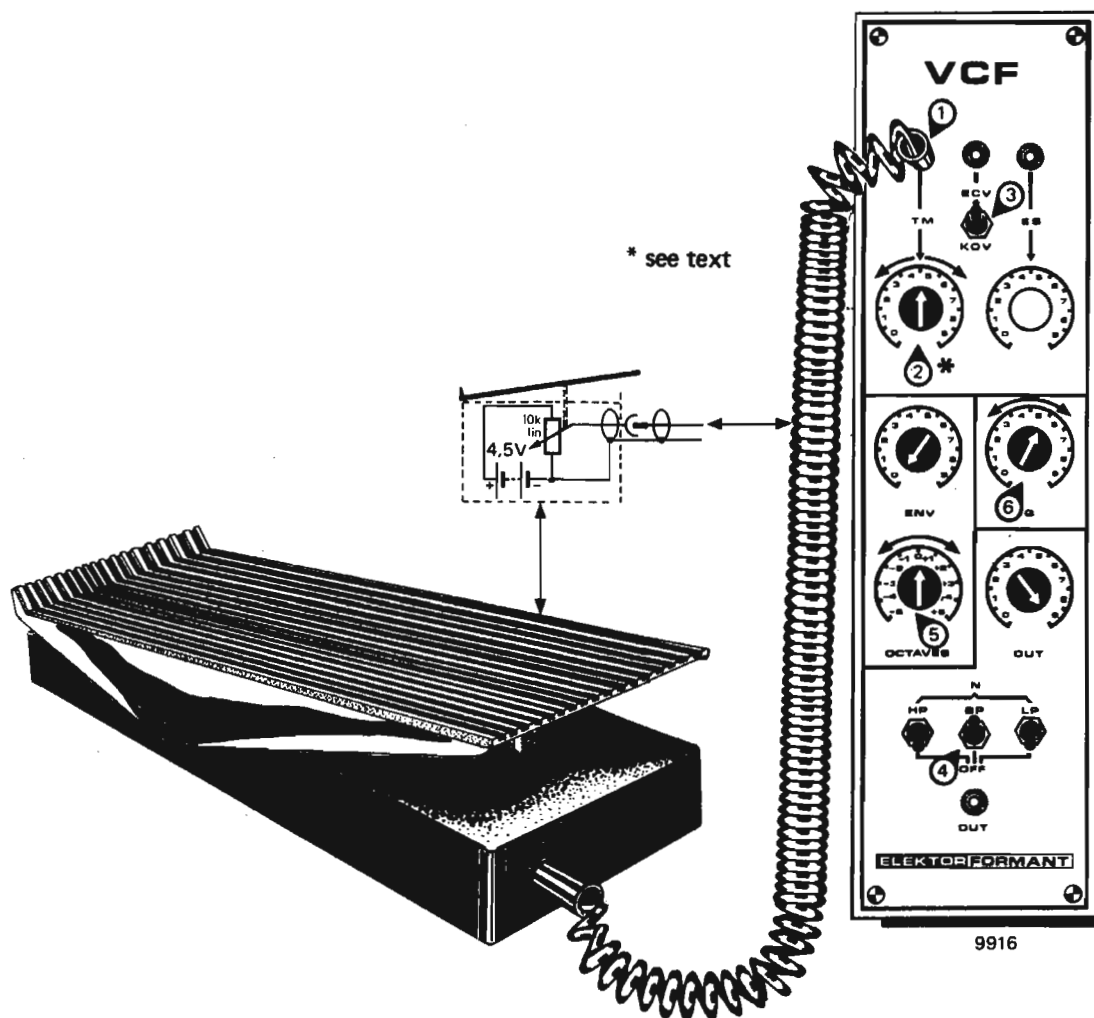

fed via two-core cable and a jack plug to the TM input of the VCF. A pedal allows much faster and more flexible control of the VCF; the ADSR envelope contours are in general too 'fixed' and slow to set up. (In this respect it is also worth while experimenting with pedal control of the VCFs when used as tracking filters, i.e. the ADSR contour is replaced by the output of the pedal)

The basic settings of the VCF for pedal controlled Wa-Wa are shown in figure 8. The output of the pedal is connected to the TM input socket (1), but initially the TM control is turned down to zero (2). As before, the external control voltage input (ECV) is selected (3), and the filter switched to a bandpass response (4).

Various notes from the desired range of frequencies are then played on the keyboard, whilst the OCTAVES control is adjusted until the resulting tones are sufficiently 'dark' (i.e. the 'W' of the Wa-Wa is obtained). With the pedal fully depressed, the TM control is then adjusted to determine how far the Wa-Wa sound 'opens'. The procedure should be repeated for several different notes, and generally a setting is chosen at which – with the pedal hard down and a medium to high Q factor – a distinct vowel-like sound, similar to 'a' (as in 'man') is obtained. Different types

of Wa-Wa effect can be produced by varying the Q factor of the filter whilst playing a note, and by switching to a lowpass filter response. By carefully adjusting the relevant parameters (OCTAVES, Q and TM controls, lowpass or bandpass filter responses) it is possible to accurately simulate the tonal characteristics of most of the commercially available types of Wa-Wa circuits. It is also possible to use the VCF to provide Wa-Wa for an electric guitar. The amplified guitar signal (which should have as rich a harmonic structure as possible) is fed to the external signal (ES) input socket, and the ES control turned up full.

### RFM

The resonance filter module contains three separate resonance filters, whose parameters (gain, centre frequency and Q) can all be independently varied. Since resonance filtering involves certain *predetermined* frequency bands being enhanced, regardless of the pitch of the note being played, there is no need for the filters to be voltage controlled. The RFM thus frees the VCF(s) for use as a tracking filter, whilst its ability to pick out more than one resonant frequency band is extremely useful in such applications as the simulation of string sounds

(see chapter 3).

The remarks made in the previous section (on the use of a VCF as resonance filter) regarding the choice of centre frequency and Q of the filter are obviously also applicable in the case of the RFM itself.

The front panel controls for the RFM are quite straightforward. The centre frequency of the filters can be varied over a nominal range of from 50 to 2300 Hz. Normally the filter parameters will remain fixed, once a particular setting has been chosen. However by rapidly varying the centre frequency and Q controls, phasing type effects can be obtained.

The RFM is provided with a bypass switch which allows the module to be switched quickly and simply out of circuit when desired.

### VCA

#### Main characteristics of the VCA

The two independently variable gain stages of the VCA provide exponential envelope (ADSR) contours for realistic simulation of the dynamic amplitude characteristics of different instruments, and periodic (linear) amplitude modulation (tremolo) of the signal waveform. The VCA is internally wired to the



The actual modulation depth is determined by the AM control, and can be continuously varied down to 0.

### Expression and swell pedal

If a pedal is connected to the AM input socket of the VCA it can be used either as an 'expression' pedal or to provide 'swell' effects. In the former case the pedal simply varies the amplitude (i.e. the volume) of the output signal as desired whilst playing. The dynamics of the notes are still controlled by the envelope contour fed to the exponential gain stage of the VCA and/or by a tracking filter. In the case of a 'swell' pedal, the envelope control input is switched off and the tracking filter set to pass the VCO signal unaltered. The pedal alone is then used to control the amplitude envelope of each note. A swell pedal is often used to vary the envelope contour of an electronic guitar signal. By providing a much slower attack phase, the guitar can be made to imitate the sound of a violin.

Figure 10 illustrates the basic front panel settings for pedal control of the VCA. Depending upon the type of effect required, the envelope control input is switched either on or off (1), and the output of the pedal connected to the AM input socket (2). The GAIN control is turned down to zero (3), whilst the AM (modulation depth) control on the other hand is set to maximum (4).

If the output of an ADSR envelope shaper is connected to the AM input via a patchcord, a linear amplitude envelope is obtained. Thus by slightly turning up the GAIN control, there is the possibility of providing an initial variable 'offset' to the amplitude envelope.

### ADSR envelope shapers

#### Main characteristics of the ADSR module

The ADSR modules of the Formant are internally hardwired to the VCF(s) and DUAL VCA. They provide a varying control voltage with exponential attack and decay characteristics, which can be used to vary the dynamic amplitude and harmonic content of a note.

The four parameters of the envelope contour which can be modified are: attack time, decay time, sustain level, and release time. The envelope shaper has two basic modes of operation, ADSR and (triggered) AD, and these are selected by means of a toggle switch on the front panel. The envelope contour can be monitored by means of an LED indicator, the brightness of the LED varying in accordance with the envelope voltage. Three main types of envelope contour can be obtained with the Formant ADSR module, these are now described in turn.

#### Attack-decay contour

The simplest envelope contour is that consisting only of attack and decay phases, i.e. when a key is depressed, the envelope voltage rises to a peak, whereupon it immediately begins to decay. For this type of contour the ADSR is operated in the triggered mode, i.e. once a note is struck, a fixed attack-decay sequence is initiated, regardless of when the key is released. AD contours are typically used to imitate percussive sounds, such as those produced by a vibraphone, xylophone etc.

The basic settings for an AD envelope are shown in figure 11. The triggered AD mode is selected (1) and the sustain control is set to zero (2), whereupon the desired attack and decay times are set up on the corresponding controls (3, 4). Depending upon whether the envelope control voltage is applied to the DUAL VCA or to a VCF (connected as a tracking filter), a variety of different tone colours can be produced by experimenting with different attack and decay periods. Interesting effects can be obtained by inverting the normal envelope of a note to provide very long attack times and relatively short decay times. Totally unnatural sounds, similar to those produced by playing a tape backwards, are the result. When playing

10

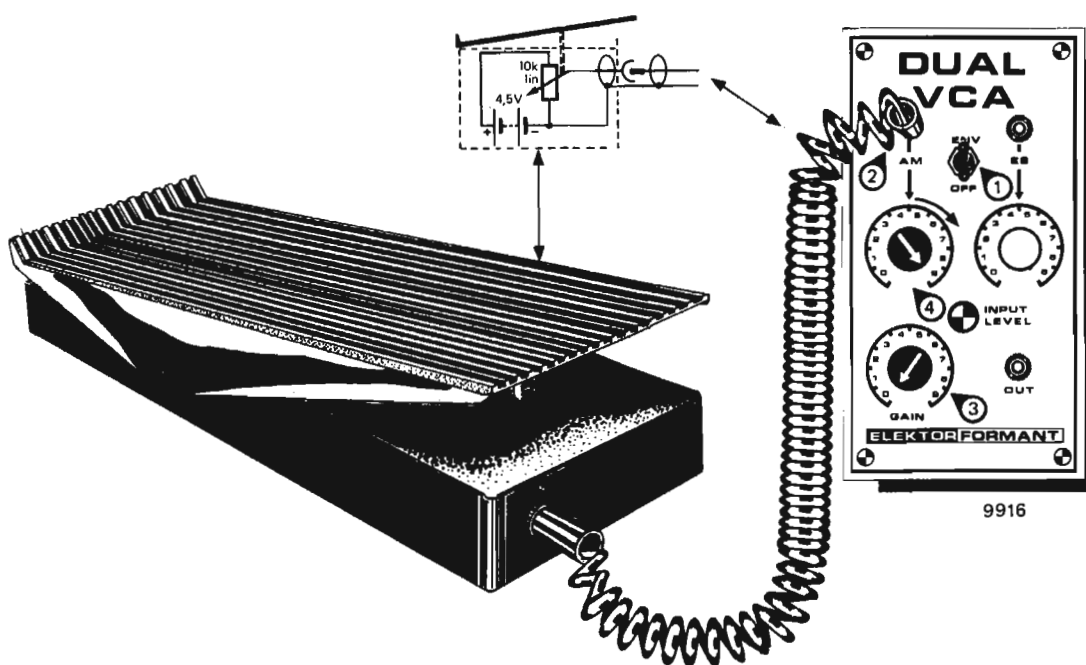

11

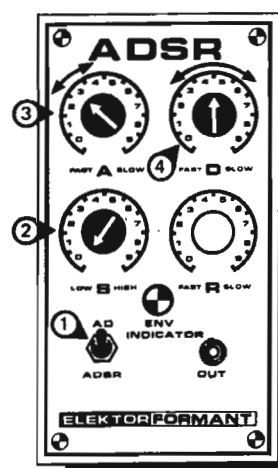

9916

with the ADSR module in the triggered AD mode it is necessary to use a slightly different keyboard technique to that employed when the sustain-release portion of the envelope is determined by the moment the key is released.

It is important to ensure that the subsequent key is struck only *after* the previous key has been released.

With certain types of instrument which have a percussive AD contour, releasing the key during the decay phase will cause the note to die away much more rapidly than would be the case were the key held down. Thus there is a relatively slow decay period, followed by a much faster release. To simulate this type of envelope contour the ADSR/AD switch is set to the ADSR mode and the sustain level set to 0% (sustain control turned fully anticlockwise). A very short attack time is selected, with a relatively long decay time; the release time should be set shorter than the decay time.

### Attack-sustain-release contour

With an attack-sustain-release contour, once the note reaches its peak it is sustained at a 'steady-state' level until the corresponding key is released. This type of amplitude contour is produced by e.g. a pipe organ. To generate an ASR envelope, the AD/ADSR switch (1 figure 12) is set to the ADSR position, the sustain level is set to 100%, and the desired attack and release times are selected as required.

### Attack-decay-sustain-release contour

The most complex voltage envelope which can be provided by the ADSR module consists of separate attack, decay, sustain and release phases. Once it has reached its peak value, the envelope voltage decays slightly before settling at the steady-state or sustain level. When applied to a VCF, this type of contour is particularly useful for simulating the changes in harmonic content which occur in the course of a note. A good example is the dynamic harmonic structure of a trumpet note, where the harmonic content initially increases to a maximum, before falling away slightly as the note is established. The basic control settings for an ADSR curve are identical to those for an ASR curve, with the exception that the sustain level is reduced to whatever value is desired, and a suitable decay time is selected. Note that the full ADSR contour will only be obtained if the attack + decay time is longer than the period for which the key is depressed, and if a sustain level of greater than 0% is chosen. If the key is released before the sustain level is reached, then the release period is initiated prematurely, and either AD or ADR curves may be produced. If the sustain level is 0%, then, once again, only AD or ADR contours may be produced, depending on when the key is released.

12

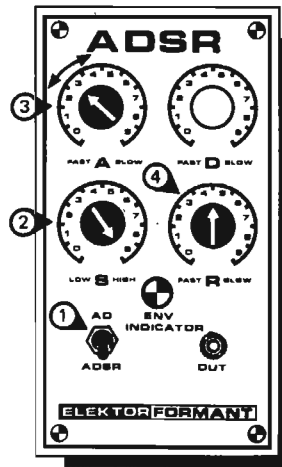

Figure 12. Setting up an attack-sustain-release envelope on the ADSR module.

### LFOs

The LFO module contains three independently variable low frequency oscillators, each of which provides a choice of three output waveforms. The frequency range of each LFO extends from roughly 5 mHz (i.e. 1 cycle every 3 minutes) to 20 Hz. Many comparably-sized synthesisers have only one low frequency oscillator, so that a VCO often has to 'double up' as an extra LFO. By having three separate LFOs each offering a choice of waveforms, a wide variety of complex (cross-)modulation effects can be obtained. LFOs 1 and 2 are identical, and provide squarewave, triangle and sawtooth (positive-going ramp) waveforms. LFO 3 produces a triangular waveform and two sawtooth waveforms in antiphase, i.e. with positive and negative going ramps respectively. The triangle output in particular is suitable for 'musical' modulation effects (vibrato, tone colour modulation, tremolo, etc.), whilst all three waveforms can be used for 'electronic' modulation effects, in which pronounced, 'non-musical' signal modulation occurs. The output of each LFO can be monitored by means of an LED indicator, the brightness of which varies in sympathy with the (triangle) output.

### NOISE module

The noise module has two low frequency outputs which provide white and pink noise (white noise with the bass components of the noise spectrum boosted) respectively, and a third extremely low frequency 'random voltage' output, the fluctuation rate of which can be varied manually. The noise signals can be patched into the Formant signal path via the ES socket of a VCF or the VCA. The noise sources can be used (with suitable filtering) to simulate the sound of cymbals and brushes, as well as unmusical sounds such as rain, wind, surf, thunder, etc. The attack transients of many orchestral instruments have large amounts of filtered white noise. The random voltage is useful for adding controlled 'doses' of random modulation so as to produce slight variations in an otherwise steady-state note. The fluctuation rate of the random voltage can be monitored by a front-panel LED similar to those of the LFOs.

### COM module

The COM contains conventional tone (bass, mid-range and treble) and volume controls, which can be used to complement the VCF(s) and tailor the overall frequency response of the synthesiser to suit individual requirements (type of loudspeaker used, room characteristics, etc.). In addition, the COM module also monitors the 3 supply voltages of the Formant and the presence (or absence) of a gate pulse.

## control settings for the simulation of different instruments 3

The control settings discussed in the previous chapter were largely limited to a description of how each module in the Formant system was operated. This chapter starts where the previous left off, and by presenting a series of basic control settings for different instruments, attempts to give the reader an insight into how the various modules can be used *together* to tailor the parameters of a note in order to achieve the desired sound.

By no means are all the significant tone settings described; rather the chapter



illustrates the various ways in which the tonal characteristics of a note can be modified and controlled. The following settings are only intended as an example, and the reader is encouraged to experiment with variations so as to appreciate the fine discriminations in tone colour of which the Formant is capable.

Considerable stress is laid upon the improvement of instrument timbre by means of resonance filtering. The examples in this respect are valid not only to the Formant, but can be applied with success to other synthesisers, and indeed practically any electronic instrument (electric guitar, string synthesiser, etc.).

### Synthesiser size and musical performance

It is sometimes said that a synthesiser with only one VCO is of little use. Such a small instrument is extremely limited in its capabilities. However this statement is almost completely unjustified, particularly when one considers that a large number of musical instruments are monophonic (including the majority of synthesisers, be they ever so large) and have only a single sound source, take for example a trumpet, clarinet, saxophone, flute, oboe, etc.

If the Formant is to be used to simulate the sound of one of the above-mentioned instruments, then it is *recommended* that, as in the case of the original, only one sound source, i.e. one VCO, is used, since as a result of the phasing effect caused by slight mistuning, several VCOs would normally alter the tone of the instrument. Thus there are a variety of applications, for which only a single VCO is required. If additional phasing or chorus effects are desired, then these can easily be provided by pulse width modulation of the squarewave output. Using only one VCO also allows the effect of the toneshaping modules in the Formant, i.e. the VCF(s) and the VCA, to be better appreciated. Thus in a large number of the following control settings for simulating certain common instruments, only one VCO is employed.

Another reason why playing with a single VCO has its advantages is that because of the monophonic keyboard, the interval of any chord will remain the same. If the VCOs are tuned in a chording group, playing for extended periods in this fashion can have rather a monotonous and 'listener-fatiguing' effect.

It can be seen, therefore, that the synthesiser enthusiast with a limited budget can start off quite satisfactorily with a 'mini-Formant', consisting of a single VCO, one state-variable VCF, one DUAL-VCA, and a single envelope shaper.

On the other hand, for the more experienced synthesiser player who wants to create finely differentiated and complex tone colours, there is virtually no limit to the number of modules which can be

incorporated into the Formant. Walter Carlos, who is probably one of the most well-known synthesiser artists, normally used 8 VCOs, 3 VCAs, and 8 ADSR envelope shapers, and he felt that 8 envelope shapers was *too few!*

More than with any other instrument perhaps, the synthesiser places great demands upon the proficiency of the person playing it. On a vibraphone, for example, it is very difficult to produce a sound which is downright discordant or unpleasant. With a synthesiser, on the other hand, nothing could be simpler! Whether the synthesiser contains a small number or large number of modules, the performance of the instrument is determined by the knowledge and skill of the player.

### Simple flute sounds

The tone-shaping process used to simulate basic flute-like sounds is illustrated in the block diagram of figure 13. The flute is a monophonic instrument with a single sound source; its timbre is rather 'hollow' and dark. A single VCO is thus used as the tone generator, and the triangle waveform, which has a mellow, 'woodwind-like' character, is chosen. The notes of a flute do not exhibit marked variations in dynamic harmonic content, and a reasonably accurate imitation can be obtained by using the ADSR (via the DUAL VCA) to control their dynamic amplitude contour only. The VCF(s) is (are) therefore set to pass the VCO signals unaltered ('allpass').

The dynamics of a flute note are characterised firstly by a soft, non-percussive attack; the note is then sustained for as long as the flute continues to be blown, and then decays fairly rapidly once the supply of air is terminated. Thus a simple attack-sustain-release envelope with reasonably (but not excessively) short attack and release times, should be set up on the ADSR module. In addition, flute tones are often characterised by a varying degree of tremolo. This can be simulated by feeding a triangle signal from one of the LFOs to the AM input of the DUAL VCA. The intensity of the tremolo can be set by means of modulation depth control beneath the AM socket.

As has already been mentioned, a reverberation unit is an extremely useful adjunct to the Formant, since it eliminates the rather 'dry' and 'clinical' sound to which synthesisers are prone. By allowing notes to decay much more gradually, the music becomes 'livelier' and considerably more realistic.

It is worthwhile experimenting with variations on the basic settings shown in figure 13. For example, if the basic configuration is preserved, but an attack-decay envelope contour is selected (ADSR is switched to triggered AD mode), then with 0% sustain level, a short attack time and a relatively long decay time, increasing the reverberation intensity will produce sounds similar to an electric piano or distinctly percussive sounds akin to those of a vibraphone.

### Simple brass sounds

The following example demonstrates how a tracking filter can be used to simulate the variations in dynamic harmonic content which are typical of brass instruments. Most brass instruments have a bright, hard, 'shiny' timbre, which is due to the comparatively large proportion of fairly intense higher harmonics in the note. Thus a suitable VCO waveform would be either the sawtooth or spaced sawtooth.

As is the case with the flute, brass instruments are monophonic, and

Figure 13. Block diagram illustrating the tone shaping process for simple flute sounds.

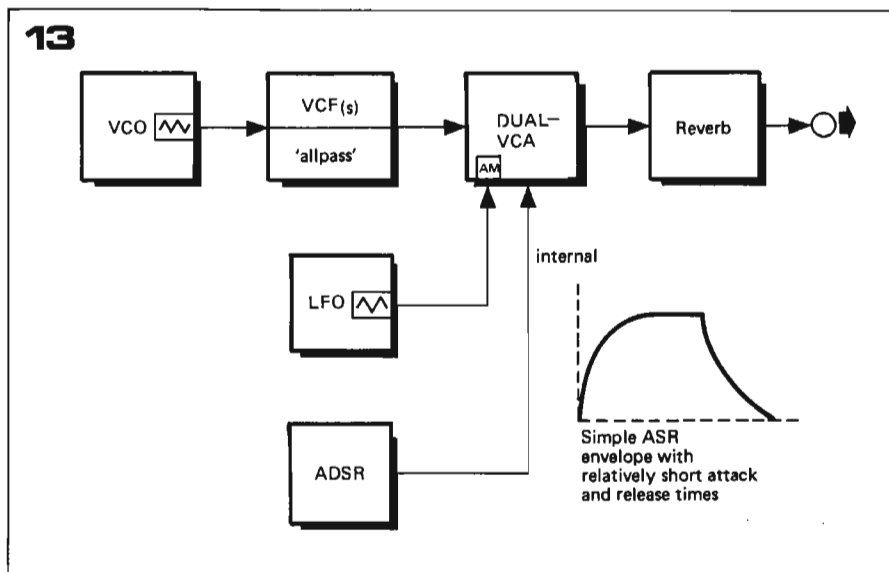

comprise a single sound source. A distinguishing feature of brass instruments generally is a pronounced build-up of harmonics during the attack period of the note. To reproduce these marked changes in tone colour, the ideal choice is to use the 24 dB VCF as a tracking filter controlled by an ADSR (see figure 14). The VCA is switched to 'OFF', i.e. is no longer under envelope control and passes the VCF output unaltered. In the absence of a 24 dB VCF, it is of course perfectly possible to employ a 12 dB VCF; however for brass instruments in particular, the severe filtering provided by the 24 dB VCF produces a more realistic sound.

To simulate basic brass-type sounds an envelope contour with a relatively long attack constant (assuming one is not playing too quickly) should be chosen. With a simple attack-sustain-release contour the note is sustained until the supply of air is cut off, whereupon it decays fairly rapidly (short release time). The Q of the VCF should be set to zero, or to only a very small value, whilst, particularly in the case of the 24 dB VCF, the ENV control should be adjusted extremely carefully. The realism of the sound can again be considerably enhanced by a certain amount of reverberation being added. Using a sawtooth waveform and turning up the ENV control slightly, it is possible to imitate a French horn or flugelhorn with considerable accuracy.

Even more detailed simulation can be obtained by employing complex attack-sustain-decay-release contours to reproduce the slight drop in harmonic content once a note is established which is characteristic of many brass instruments (see figure 5, chapter 9). 'Ethereal' brass-type sounds can be produced by 'shallow' timbre modulation using the triangle output of an LFO, and turning up the ENV control fairly high. If adjusted correctly, the instrument will sound like a mixture of a softly-played trumpet and a brightly played flute. If an echo unit is used, the brass sounds of the Formant are lent a chorus-like, multi-voice character.

### Realistic tone colour through resonance filtering

Although the above control settings realistically simulate the dynamic tone colouration of brass instruments, the sound still remains slightly unsatisfying when compared to the 'real thing'. The natural sound of a trumpet is brighter and more intense, the trombone is 'fuller', more rounded, whilst the tuba has a richer bass. The corresponding synthesiser sounds seem to have less character, are a slightly 'pale' imitation. The reason for this is that the trumpet, trombone, French horn, tuba, etc. are distinguished not only by their different pitch and dynamic harmonic content, but also by differences in their resonance modes. Due to its particular shape and size, each instrument possesses different

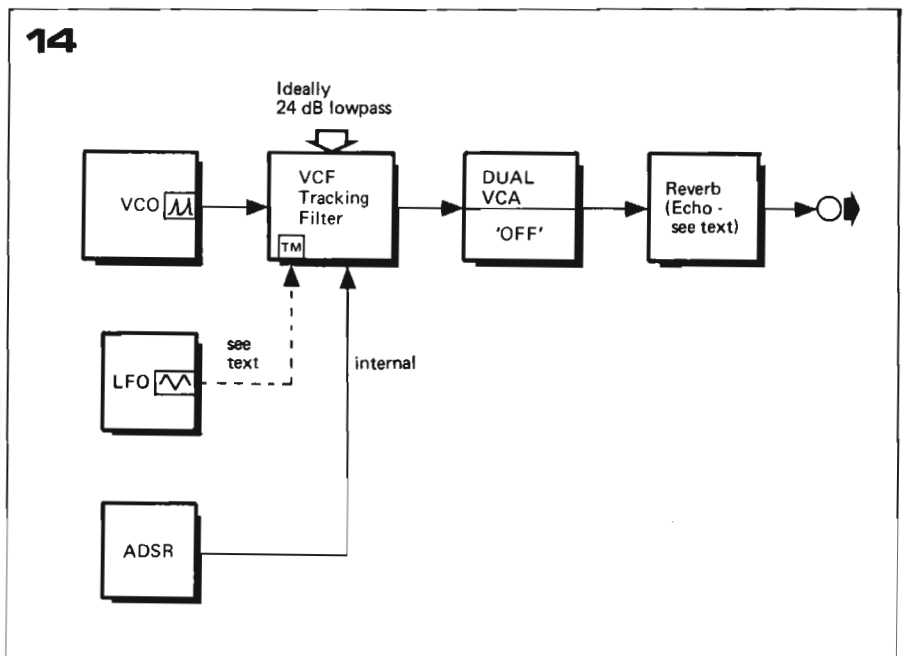

bandpass resonances (formants), which greatly influence its basic timbre.

In the case of the tuba, for example, the predominant bandpass resonance is much lower (around 250 Hz) than that of the trombone or the trumpet, and this is partially responsible for the rich bass character. In the case of the French- and flugelhorn, because of their greater Q factor, the primary resonances cause a much more marked colouration of timbre than is true of the other brass instruments.

The importance of resonance filtering is not limited to brass instruments; the resonant frequency bands or formants of woodwind instruments such as bassoon, oboe, clarinet, flute, etc. have just as much effect on their tone colour. In the case of string instruments, the situation becomes more complicated. For although bandpass resonances play just as significant a role in determining timbre, the large number of formants which string instruments possess make them difficult to simulate with limited resources.

The following examples illustrate how resonance filtering can provide a more realistic timbre when synthesising brass, woodwind and string instruments. For simple resonance filtering, either the resonance filter module itself, or the 12 dB VCF (bandpass mode) can be used. For simulating several bandpass resonances, such as when synthesising string sounds, the resonance filter module is a 'must'.

### Improved brass sounds

The basic control settings described in the section on 'Basic brass sounds' are retained, the difference is that a resonance filter is introduced into the signal path (see figure 15). The main fixed resonances of a number of brass instruments are listed in the table shown below (see also the table contained in the chapter on the resonance filter

Figure 14. Block diagram illustrating tone shaping process for simple brass sounds.

Figure 15. Improved brass sounds.

Figure 16. Tone shaping process for synthesising clarinet, bassoon, and oboe sounds.

module). When the table was compiled, the author experimented with different centre frequencies of the resonance filter for a variety of different Q factors, until the resultant sound was closest in each case to the original instrument. The results obtained largely coincided with the actual resonant frequencies (SIRKER 1974).

Instrument	Main resonance
trumpet	1500 Hz
flugelhorn	1000 Hz +)
trombone	600 Hz
French horn	400 Hz +)
tuba	250 Hz

+ ) increased Q factor

Initially the centre frequency of the resonance filter is set to the nominal value listed in the table. The Q of the filter is adjusted to roughly its mid-position. For trumpet and trombone sounds, spaced sawtooth waveforms are particularly suitable, whilst ordinary sawtooth will suffice for tuba, French horn and flugelhorn. The ENV control should be turned fairly far up for trumpet and trombone, and even further up for the other brass instruments mentioned above. The Q of the filter should also be increased for the flugelhorn and French horn. For the resonance filtering to achieve the desired effect,



15

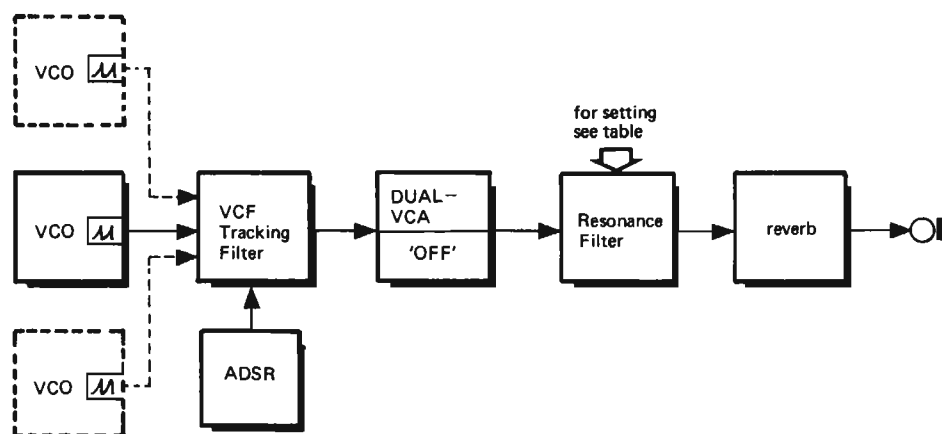

16

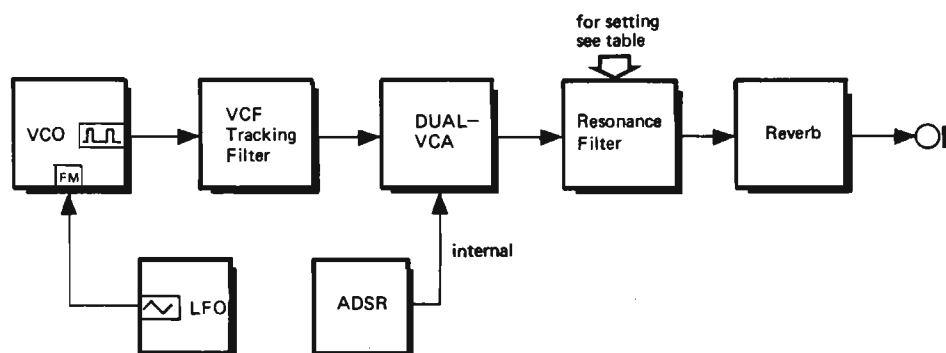

the synthesiser should be played within the natural frequency range of the instrument concerned. In each case care should be taken to ensure that the pitch of the notes played are on average below the centre frequency of the filter. If this is not the case, the filter will fail to enhance various upper harmonics of individual notes, and the desired tone colouration will be lost.

To assess the effect that resonance filtering has on the timbre of the sound, one should play several tunes which extend over a number of octaves. The fixed centre frequency of the filter will cause the tone colour of the sound to vary for different pitched notes; the overall tonal character of an instrument is after all determined by how it sounds at different pitches. Think for example of the sonorous timbre of a cello at the lower end of its scale compared to how it sounds on the higher notes. If sufficient care is paid to exact adjustment of the Q factor and centre frequency of the resonance filter, and to the careful setting of the ENV control of the tracking filter, the resulting sounds should have a thoroughly convincing musical quality. The improved brass sounds are thus a good example of the type of musically satisfying effect that can be obtained using only one VCO.

### Multi-voice brass sounds

As a conclusion to experimenting with the synthesis of brass sounds, one should try employing several VCOs, tuned to e.g. simple major or minor chords. Depending upon the control settings, fanfare-like effects, or background 'brass section' sounds can be produced. By varying the envelope contour of the signals, either short, rhythmic notes, or notes which rise and decay extremely slowly, can be obtained. Multi-voice brass sounds are ideally suited to provide background accompaniment to solo instruments such as a mini-Formant or electric guitar. The invariant chords are not perceived as irritating or fatiguing, but rather provide a pleasant contrast to the foreground melody-line.

### Some typical synthesiser effects with no natural equivalents

If one retains the basic control settings of figure 15 but varies the envelope contour controlling the VCF (tracking filter) to provide very short attack times and slightly longer decay times, extremely attractive *metallic sounds* are obtained. By varying the centre frequency and Q of the resonance filter, a spectrum of sound from very dark, 'bassy' tone colours through a variety of

timbres including that of metal strings being struck, to very bright, sharp string sounds, can be distinguished.

The majority of these sounds have no natural equivalent, and appear more or less 'artificial' to the ear. The 'electronic' sound can be further enhanced by increasing the Q of the tracking filter. It is also worthwhile experimenting with the highpass, lowpass and notch filter functions of the VCF used as resonance filter. Starting with the basic configuration shown in figure 15 it is relatively simple to generate a variety of different 'fantasy' sounds, which although they do not resemble conventional instruments nonetheless can be extremely pleasurable.

### Oboe, bassoon and clarinet

A number of conventional instruments also have pronounced tone colouration, e.g. the oboe, bassoon and clarinet. As was the case with the flute, the variations of harmonic content during a note are of secondary importance. As far as their synthesis is concerned, this means that the DUAL VCA is used to determine the dynamics of the individual notes. The amplitude dynamics are similar to those of the flute, i.e. a simple attack-sustain-release curve is all that is required

for a reasonable simulation. Each of the instruments, however, has a highly individual timbre, which cannot be accurately imitated without resonance filtering.

The sound of a symmetrical squarewave is quite similar to that of a clarinet, but without the presence of formants, the 'synthesised' clarinet is unconvincing at the lower end of the scale; sounding 'sterile' and electronic, with the typical 'nasal tone' missing on the lower notes. The timbre of the oboe and bassoon is not similar to that of any of the VCO waveforms, nor can it be derived with the aid of a tracking filter. In other words, although it is possible to imitate basic brass sounds fairly successfully without resonance filtering, the same is *not* true for the clarinet, whose timbre can only be accurately synthesised with the aid of a resonance filter. The effect of resonances on the timbre of the oboe and bassoon is even more marked than is the case with the clarinet.

Realistic clarinet, oboe and bassoon, not to mention saxophone and flutes, are a distinguishing feature of the Formant – due to the emphasis on resonance filtering as part of the basic design concept.

The following table lists the main fixed resonances of the clarinet, oboe and bassoon (see also the table in chapter 8 Part 1).

Instrument	Main resonance
clarinet	1000-2000 Hz
oboe	1300-1700 Hz
bassoon	440 Hz

For the synthesis of bassoon and oboe sounds, a heavily asymmetrical square-wave is the most suitable type of VCO waveform, whilst a symmetrical square-wave (obtained by careful adjustment of the PW control on the VCO) is the obvious choice for the clarinet. For all three sounds a relatively high Q factor is needed, especially in the case of the oboe and bassoon. The tracking filter is set to 'allpass', although by suitable adjustment of the OCTAVES control the higher harmonics of each instrument should be slightly muted. The dynamics of the individual notes are controlled by means of the DUAL VCA (see figure 16). If the resulting sound is frequency-modulated slightly, a 'singing' effect, which reproduces the typical vibrato of these instruments, is obtained. Once again, the use of controlled amounts of reverberation is recommended. With careful adjustment of the relevant parameters, the Formant will imitate the three above-mentioned instruments with a remarkable degree of accuracy. In the case of other reed instruments, the importance of resonance filtering is equally crucial. By varying several of the parameters in figure 16, sounds covering e.g. the range of soprano to baritone saxophones can be produced.

### String instruments

For brass and woodwind instruments

the role of bandpass resonances in determining the basic timbre of the instruments was vital. In the case of string instruments however, the importance of resonance filtering is less important. The acoustic response of string instruments is much less coloured by the effect of a main fixed resonance. This is on account of the particular shape of most string instruments, which possess not one or two, but a large number of resonances extending over the entire audio range. This means that a single bandpass filter is insufficient; a resonance filter bank such as the Formant RFM, containing several independently variable bandpass filters is required. Even then however, the simulation of individual string instruments remains a problem. The note from a violin or cello is initiated when the bow comes into contact with a string; that corresponds to an envelope contour with a slow attack constant fed to the DUAL VCA. As the string begins to stop oscillating, so the note begins to decay gradually. However during normal playing, the string will be maintained in a state of oscillation by further movement of the bow. The resulting envelope of the note is extremely complex, too complex to be accurately reproduced using a simple envelope shaper.

However, a *reasonable* approximation to a string instrument can be obtained with a straightforward attack-sustain-release envelope, leaving aside the 'steady-state' dynamics of the note and the (important) nuances of multi-voiced orchestral string sounds for the moment. The question may be asked whether, in view of the difficulties involved, one should renounce the attempt to synthesise string instruments. The answer is certainly not! However one should simply be aware of the fact that 'string sounds' will not have quite the convincing realism as the other types of instrument which have already been discussed. Nonetheless there are many musical applications which call for a sound which is similar to that of a cello or violin, and these the Formant is perfectly capable of synthesising.

No block diagram is given for the synthesis of string sounds, since they can in fact be produced in several different ways. Suitable types of VCO waveform (one should begin with a single VCO) are sawtooth, spaced sawtooth or asymmetrical squarewave. The tracking filter is set to the 'allpass' mode, to pass the VCO signals unaltered, with the exception of the upper harmonics of the signals, which, by adjusting the OCTAVES control, are slightly attenuated. In practice a slight amount of vibrato has proven useful.

The following table gives an approximate guide to the centre frequency of the resonance filter module.

As has been explained, the tonal significance of the primary resonances listed in the table is less profound than was the case with brass or woodwind instru-

	Main resonance*
double bass	
violin	approx. 400 Hz
cello	approx. 200 Hz
double bass	approx. 100 Hz

ments. Nonetheless, useful improvements in tonal realism can be obtained with the aid of the resonance filter module. The additional use of a phaser or flanger is also recommended. The comb-filter like response of the phaser provides a number of fixed 'peaks' or resonances in the signal, which, if carefully situated, will considerably enhance the timbre of the sound.

The DUAL VCA is controlled by a simple attack-sustain-release envelope, with a fairly slow attack time and relatively fast release. A healthy amount of reverberation is also very important. To get as close as possible to the natural sound of string instruments, it will be *necessary* to experiment with varying the parameters of the resonance filter, the placing of the peaks and notches provided by the (unmodulated) phaser, as well as the attack and decay times of the envelope contour and the amount of upper harmonic attenuation introduced by the tracking filter.

Once the optimum settings – particularly of the resonance filter – for double bass, cello, violin and viola have been determined, switching in a second VCO which is tuned in unison with the first will produce an 'orchestral' effect. This is due to the creation of beat frequencies caused by very slight mistuning between the two VCOs, and lends the sound a lush, 'choral' character. The effect can be further intensified by switching in a third VCO, also tuned in unison with the other two, and by independently pulse width modulating the squarewave output signals of one, two or all three VCOs. Another possibility is to frequency-modulate (vibrato) each VCO, when the latter are tuned in unison or to chording intervals. By carefully adjusting the vibrato frequency and the modulation depth (intensity) it is possible to obtain a convincing simulation of a note played by a large string section. Slow modulation of the phaser response (i.e. gradually sweeping the peaks in the response up and down the audio spectrum) can further reinforce the orchestral timbre of the note.

Finally, it is worthwhile experimenting with tuning the VCOs in chording groups. If acceptable orchestral sounds have been successfully obtained, one should try synthesising minor chords. These more complex types of sound are ideally suited as an orchestral background for other instruments.

### Improved flute sounds

At the beginning of the chapter the control settings for synthesising simple flute sounds were described. However

\* Ideally reinforced by resonance filter bank or comb filter

the attentive listener will have noticed that there were a number of deficiencies in the tonal character of the resultant sound. These can be largely eliminated by employing a slightly more elaborate tone-shaping process. The basic timbre of the simple flute sounds was determined *solely* by the character of the triangle waveform; the resulting sound being *fairly* similar to that of the (old) *woodwind* flute, but quite foreign to the 'silvery' timbre of a modern (German) flute. In addition, the characteristic enhancement of certain upper harmonics as a result of the instrument's resonances was also missing. A further inadequacy was the simulated tremolo, which in the case of a real flute is more than simple amplitude modulation. With a modern flute in particular, the amplitude modulation is accompanied by clearly discernible periodic fluctuations in tone colour. As the amplitude of the note increases during tremolo modulation, so the timbre of the note becomes brighter. This effect is especially noticeable on the lower notes of a German flute.

The question therefore arises, how does one go about simulating these characteristics? First of all, if one wishes to imitate the timbre of a modern (metal) flute, then a slightly asymmetrical squarewave is a more appropriate waveform to start with than the triangle. The intense upper harmonics of the squarewave must be severely suppressed with the aid of the 24 dB VCF. De-

pending upon the type of flute to be simulated, resonance filtering to create the corresponding formant bands is also necessary. As a rough guideline for the position of the main fixed resonance of a German flute one can start with a centre frequency for the bandpass filter of approximately 800 Hz.

The amplitude dynamics of the individual notes are tailored to a simple attack-sustain-release contour with the aid of the ADSR and DUAL VCA. To provide a more realistic tremolo effect, dynamic timbre modulation, if necessary controlled by hand, is used in place of amplitude modulation. The resulting sound should be much more 'lively' as a result of this step. In comparison, amplitude modulation alone sounds expressionless.

The basic set-up for improved flute sounds is illustrated in figure 17. A few points on the nuances of the control settings: initially the *symmetrical squarewave*, which sounds similar to a clarinet or woodwind flute, is selected. The OCTAVES control on the 24 dB VCF (switched to the lowpass mode) is gradually turned anticlockwise, whilst playing several notes on the keyboard, until a comparatively soft, mellow, flute-like timbre is obtained. Using the triangle output of an LFO, a slight amount of timbre modulation is introduced (TM input and control on the VCF); the frequency of the LFO signal should be kept fairly low. With a medium to high Q factor, the centre

frequency of the resonance filter is then set to a roughly 800 Hz, thereby ensuring that the lower notes of the flute in particular lose their 'electronic' character. The DUAL VCA is used only to control the amplitude envelope of each note; the AM control is turned down to zero.

Once the basic control settings have been carried out, there comes an extremely important adjustment - the PW control of the VCO is turned very slightly, only 1...2 mm, off-centre (the direction is irrelevant). This has the effect of providing a slightly asymmetrical squarewave, and changes the timbre of the sound from that of a woodwind flute to the desired 'silvery' tone colour of a metal flute. The setting of the PW control should be carefully checked by ear, for it is of critical importance for a realistic simulation of the flute tones. It is also important that the OCTAVES control of the tracking VCF be turned down far enough to eliminate any 'buzzy', 'electronic' edge to the sound caused by the upper harmonics of the squarewave. On the other hand, it should not be turned down so far that the resultant sound becomes sterile and lifeless. It is recommended adjusting the TM control by hand whilst playing, so that at certain points during a note or tune the tremolo is further enhanced. Finally, a tip for those bitten by the experimenting 'bug': by reducing the pitch of the flute and its resonant frequency to 400 Hz, or even as low as

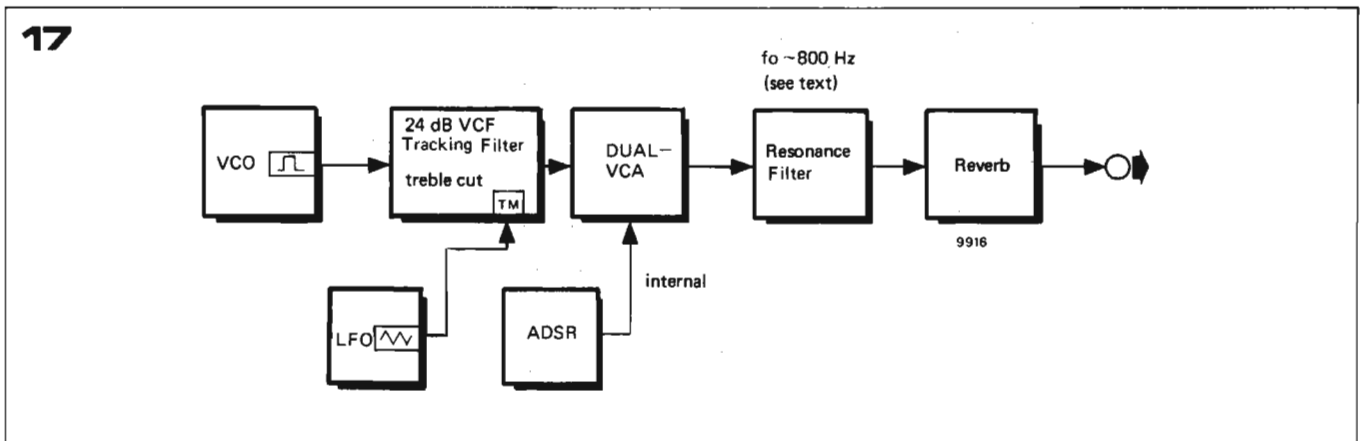
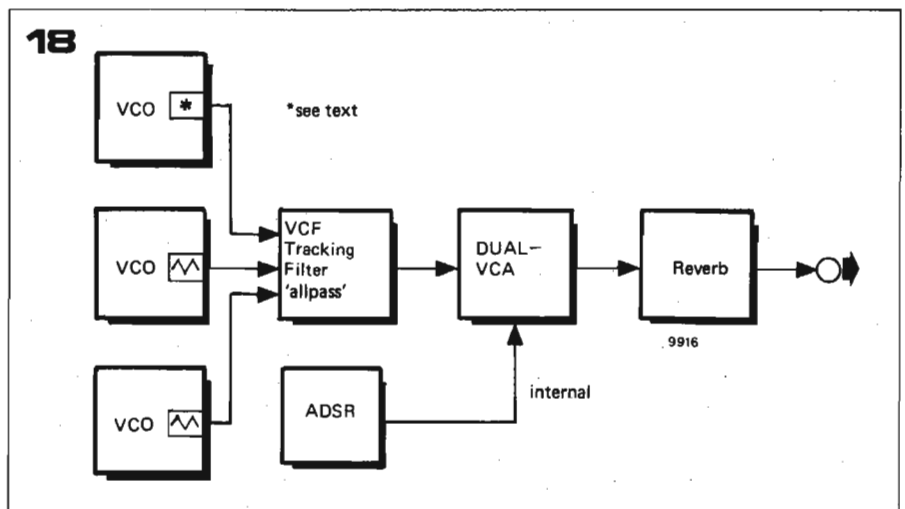
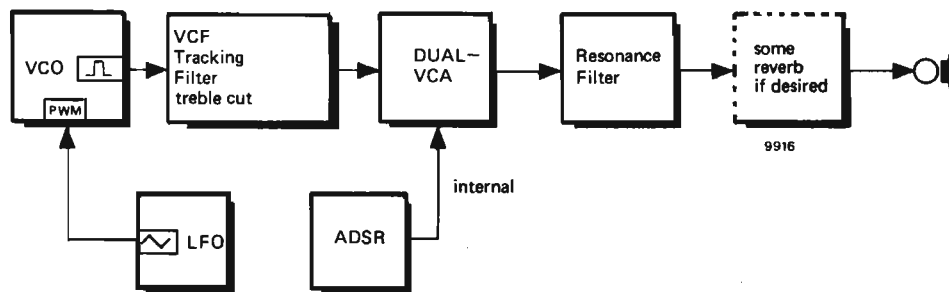

Figure 17. Control settings for improved flute sounds.

Figure 18. Control settings for organ sounds.



19



250 Hz, sounds similar to those of a bass flute can be obtained.

### Organ sounds

In contrast to the above example of string sounds, the simulation of an organ is extremely simple (see figure 18). First of all the three VCOs are tuned to intervals of an octave and the triangle or sine wave is chosen as the output waveform for the two lower VCOs. If a church organ sound is desired, a symmetrical squarewave should be used for the top VCO; if a similar but less strident type of sound is required, the triangle waveform is more suitable. For a trumpet-like organ register, the sawtooth or spaced sawtooth should be used for the top octave. The proportions in which the individual octaves are mixed are adjusted using the OUT controls on each VCO. A simple attack-sustain-release envelope, which is fed to the DUAL VCA, determines the dynamics of the notes. Relatively short attack and release times are used. At the top end of the scale, where the fundamental frequency of the top octave signal is above 2 kHz, the organ tones have an agreeable 'silvery' character, which is reminiscent of the sound produced by the smallest pipes of a conventional organ. For all types of organ sounds it is recommended that a considerable amount of reverberation be added.

### Piano- and piano-related sounds

The range of keyboard instruments related to the piano is extremely wide. It extends from the grand piano, with its deep, soft bass notes (when played 'pianissimo') through honky-tonk type piano voices, to the bright highly percussive sounds of the harpsichord, spinet, etc. One could also include the wide variety of sounds obtained from different types of electronic piano in this group.

With the important restriction of being monophonic, the Formant is capable of synthesising the majority of the above-mentioned instruments. Disregarding peculiarities of individual keyboards, most piano-related sounds have in common the fact that, by depressing a

key, a hammer strikes one or more strings, causing it (them) to vibrate at a given frequency. The individual notes have a fast, percussive attack, then decay relatively slowly. When the key is released, dampers, which were raised the moment the key was struck, fall back onto the string(s) and terminate the note comparatively rapidly.

A second characteristic of the majority of piano type sounds is that the variations in dynamic amplitude described above are generally not accompanied by pronounced variations in harmonic content. A further feature of piano-like sounds is the presence of periodic 'notches' in their response; for this reason an asymmetrical squarewave is the most obvious choice of VCO output waveform. For certain clavichord and electronic piano sounds the sawtooth and spaced sawtooth are also suitable. In spite of the less marked dynamic harmonic behaviour of piano-related sounds the two tracking filters in the Formant are not left idle. The 24 dB VCF can usefully be employed to suppress the intense upper harmonics of the asymmetrical squarewave when imitating a pianoforte, removing the 'fuzzy' electronic edge to the notes. The resonance filter is used to reproduce the main fixed resonance of the piano (fairly low Q factor). A typical feature of the voicing of a piano and grand piano is the somewhat 'soft' bass notes, which sound slightly dry, with no suggestion of bass 'drone'. The middle register on the other hand sounds richer (generally speaking the hammer strikes several strings, as opposed to the bass notes where each hammer strikes only a single string), whilst the upper notes again sound relatively soft (assuming one is not playing 'forte'). This points to a bandpass resonance between the middle and lower end of the piano scale (depending upon the type of sound desired). The importance of a low Q factor has already been mentioned.

Widely differing resonance filter settings will be required for other piano-related instruments such as the spinet, harpsichord, and in particular the clavichord. The same is true for electronic piano sounds, where personal taste will largely

dictate the parameters of the resonance filter.

The following description of control settings applies to the simulation of pianoforte and grand piano sounds (see figure 19).

An asymmetrical squarewave (roughly 10 to 20% mark-space ratio) is selected, whilst a relatively low frequency triangle waveform is fed as modulation signal to the PWM input of the VCO. The PWM control is only turned up very slightly, so that the phasing effect is just audible. With the aid of the 24 dB VCF (ENV control turned right down to zero) the upper harmonics of the squarewave are gradually attenuated (treble cut) until the desired timbre is obtained. First of all, however, a suitable envelope contour should be set up on the ADSR module and fed to the DUAL VCA (see description of attack-decay-release envelope in previous chapter). Finally the centre frequency of the resonance filter (low Q) is adjusted until the higher piano notes are sufficiently soft and the bass notes suitably 'dry', but without being too sterile.

For honky-tonk type sounds, two VCOs are slightly mistuned with respect to one another. In the case of a mini-Formant, where only one VCO is available, the frequency of the PWM modulation signal must itself be modulated. The percussive attack characteristics of honky-tonk notes can be reinforced by using an attack-decay envelope (very short attack- and decay times) to control the 24 dB tracking filter; the ENV control is turned up slightly, whilst the other settings of the VCF remain unaltered. The result is a characteristically 'jangly' sound, with very bright attack characteristics.

### Gong, bell and glockenspiel sounds

All the various sounds described so far had in common the fact that they possessed a *musically coherent* harmonic structure. The last category of sound to be discussed in this section (see figure 20) is that of gongs, bells, and percussive instruments generally, which have a musically unrelated harmonic structure. This type of effect can be useful in a

20

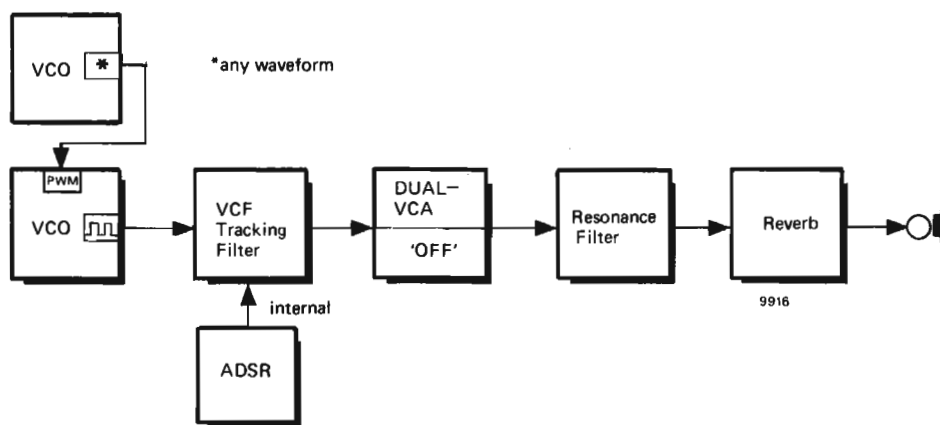

Figure 19. Control settings for simple piano-like sounds.

Figure 20. Tone shaping process for gong and bell-like sounds.

variety of applications from stage sound effects to 'experimental' music.

The basic control settings involved are comparatively simple. Two VCOs are employed, one providing a pulse width modulation signal for the other (this ring modulator like configuration is described in chapter 2). The 24 dB tracking filter under ADSR control is used to tailor the dynamics of the notes. A percussive attack-decay contour with a very short attack time and long decay time should be employed. The two VCOs are then tuned until the timbre of the resultant sound is similar to that desired (i.e. bell or gong-like); note that only one VCO output control is turned up.

Assuming the dynamic tracking filter has been switched in, the simplest types of sounds to set up are those of bells. Somewhere between the many 'short-wave' radio noises typically produced by ring modulators can be found a wide variety of differentiated tone colours covering the timbre of every possible type of small and large bell, gongs, clock chimes, etc. The more resonant, 'darker' timbre of large bells, and the lighter tone colour of small(hand) bells, can be usefully enhanced with the aid of the resonance filter.

### Further tonal possibilities

The full capabilities of the Formant have by no means been exhausted — particularly if one has a large system

with many modules. Many of the more complex control settings have been omitted for reasons of space, whilst comparatively little has been said on the subject of synthesising wholly 'electronic' sounds, the use of noise for special effects, or on the techniques of portamento playing. However this merely means that the Formant user has ample scope to experiment on his own and to enjoy the pleasures of discovering for himself the full range of tonal possibilities which the Formant can realise.

### Using the FORMANT with other instruments

The Formant can not only be played as a solo instrument, but is well suited to be used in conjunction with a wide variety of other instruments. For enthusiasts of electronic music, there is the obvious possibility of using several synthesisers, e.g. a combination of a 'full-scale' and mini-Formant (consisting of only one VCO, VCA, VCF and ADSR). The large Formant is employed to provide an orchestral background, whilst its 'little brother' plays the melody line (generally speaking the two synthesisers would then be played by separate people). Another useful addition to the Formant is a good electronic piano or sophisticated organ. As a rule synthesisers gain much from being used in conjunction with other instruments. They can be likened to a large room full of different instruments, but with only one player available to use them. One way of circumventing this problem is to use tape, although there is the drawback of the relatively high cost of good quality tape machines. The flexibility and scope of a synthesiser are best demonstrated when used in a band, where its range of tonal possibilities can be exploited to contrast with the differently structured sounds of the other instruments. Such interplay with other types of instrument can also prove musically highly stimulating for the Formant user.

In conclusion, all that remains is to wish the prospective Formant user a fruitful 'voyage' of musical discovery and many happy hours of experimenting!

### Literature:

- CARLOS, W.: 'WALTER CARLOS on synthesisers' letter published in *WHOLE EARTH CATALOGUE 1974*
- HUTCHINS, C.M.: 'Instrumentation and methods for violin testing'. *JAES*, Vol. 21, Sept. 1973, No. 7, 563-570
- STRONG, W. and CLARK, M.: 'Synthesis of wind-instrument tones'. *JASA*, Vol. 41, No. 1, 1967, pp 39-52
- CHAPMAN, C. and DÜREN, W.: 'Synthesizer-Spezial'. *Fachblatt-Musik-Magazin* Dec. 1977 to May 1978
- SIRKER, U.: 'Strukturelle Gesetzmäßigkeiten in den Spektren von Blasinstrumentenklängen'. *ACUSTICA*, Vol. 30, No. 1, 1974

**COM**  
B T  
GATE  
M VOL  
-15V +5V -15V  
OUT 1 OUT 2  
ELEKTORFORMANT

**NOISE**  
PART 1 SIGNAL  
WHITE COLOURED RANDOM  
NOISE NOISE VOLTAGE  
ELEKTORFORMANT

**LFOs**  
PART 1 SIGNAL  
PART 2 SIGNAL  
PART 3 SIGNAL  
ELEKTORFORMANT

**ADSR**  
PART A SIGNAL PART D SIGNAL  
PART B SIGNAL PART R SIGNAL  
AD ENV INDICATOR  
ADSR OUT  
ELEKTORFORMANT

**ADSR**  
PART A SIGNAL PART D SIGNAL  
PART B SIGNAL PART R SIGNAL  
AD ENV INDICATOR  
ADSR OUT  
ELEKTORFORMANT

**DUAL VCA**  
ENV OFF  
ENV ON  
INPUT LEVEL  
GAIN  
OUT  
ELEKTORFORMANT

**VCO**  
FM ECV DWM  
KOV  
OCTAVES  
FINE PW  
COARSE OUT  
ELEKTORFORMANT

**VCO**  
FM ECV DWM  
KOV  
OCTAVES  
FINE PW  
COARSE OUT  
ELEKTORFORMANT

**VCO**  
FM ECV DWM  
KOV  
OCTAVES  
FINE PW  
COARSE OUT  
ELEKTORFORMANT

**VCF**  
TM ECV  
KOV  
ENV Q  
OCTAVES OUT  
ELEKTORFORMANT

**VCF 24dB**  
TM ECV  
KOV  
ENV Q  
OCTAVES OUT  
HP VCDs  
LP ES  
OUT  
ELEKTORFORMANT

**RFM**  
F# G A  
F# G A  
F# G A  
ON  
BYPASS  
OUT  
ELEKTORFORMANT

INTERFACE  
PORTAMENTO  
DETAILED  
COARSE FINE  
OFF  
ELEKTORFORMANT

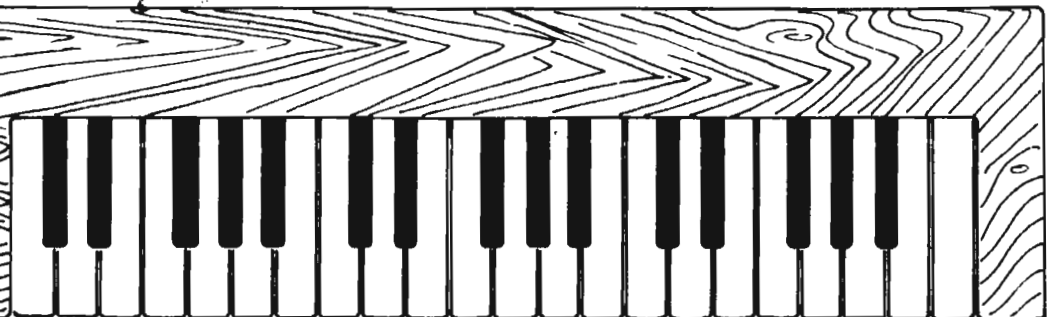

When the Formant circuit was developed, FET Opamps and especially the 'high-speed' versions were practically non-existent. The only economical alternative was to use standard Field-effect transistors in the well-known source follower circuit (figure 1a).

As those who have heard the Formant will know, this solution works. However, there are certain disadvantages.

1. The amplification achieved is not precisely 1, but slightly less (approximately 0.9).
2. Because of tolerances in the FETs, the source resistor has to be selected carefully.
3. The gate-source bias voltage ( $U_{GS}$ ) causes a certain 'offset' in the output

# FET opamps in the Formant

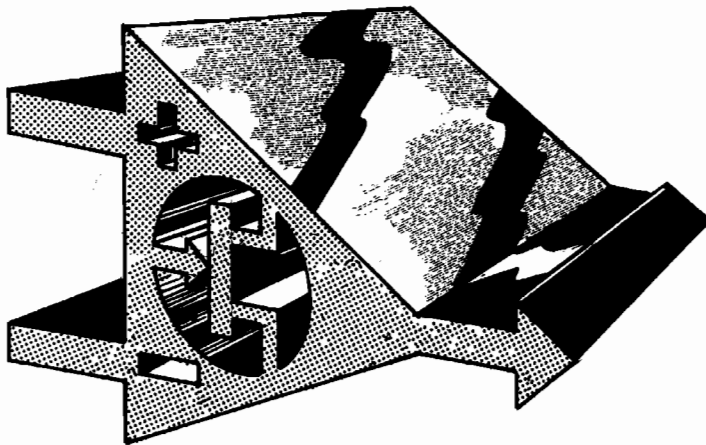

At several points in the Formant music synthesiser circuits (described in Elektor, May 1977 . . . April 1978), FET source followers are used as high-impedance output buffers. This type of stage is not always the best solution and an alternative is well worth considering: an operational amplifier with an FET input stage. This article will examine the use of these more up-to-date components and will give a description of ways to adapt the VCO's.

voltage, with respect to the input voltage. This must be compensated in one of the following stages.

4. The dynamic range is relatively small.
5. The gate-source bias voltage is temperature-dependent and therefore the output voltage tends to drift.

These disadvantages are not so serious — they don't limit the Formant's potential as a musical instrument. Nevertheless, it is better to avoid them altogether by replacing the FET source follower circuit (figure 1a) by a voltage follower circuit, using an FET opamp (figure 1b). All source followers in the Formant (in the Interface, VCO and VCF circuits) can be eliminated in this way.

### When is it worth it?

One of the FET source follower's greatest drawbacks is its temperature

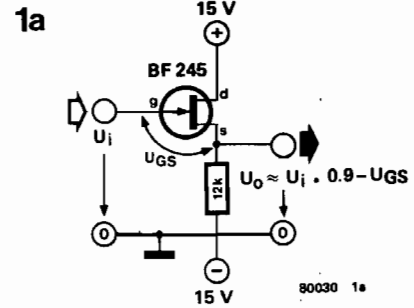

Figure 1a. A source follower with an N-channel-field effect transistor. This stage serves as a high-impedance buffer in the Formant Interface, VCO and VCF circuits.

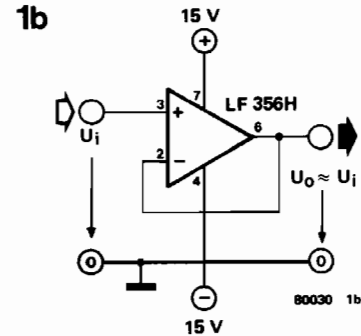

Figure 1b. Voltage follower using an FET operational amplifier. This circuit can replace the FET source followers in the Formant and provides better temperature stability.

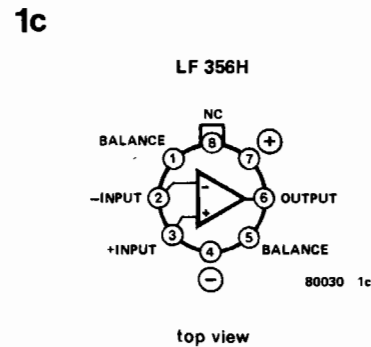

Figure 1c. Pinning of the LF 356H.

drift. The other disadvantages affect the construction (making it more complicated and time-consuming) rather than the quality.

In a VCO, in particular, the temperature drift should be reduced to a minimum, because when several VCO's are used together any mistuning is immediately audible. As far as the Interface is concerned, temperature drift may cause the entire circuit to be out of tune, which can be heard when it is played together with other instruments. In practice, this is rarely a problem and so there doesn't seem to be much point in converting this module to FET opamps. Only if you're dealing with a keyboard compass of more than 5 octaves (and



therefore a greater dynamic range), it may be advisable to use FET opamps instead of source followers. The low slew-rate requirements in the Interface mean that economical FET opamps (TL084 and TL074) can replace source followers T1, T3 and T4. The fourth opamp can take over the function of one of the 741s (IC5 or IC6, for instance). All these changes will involve a lot of 'flying wires'! Once the circuit has been modified, the offset adjustment (P4) must be repeated.

In the VCF, the FET's have no real effect on the temperature stability, so that little would be gained by modifying it.

### FET opamps in the VCO

VCO's which are already in use can easily be converted. However, their oscillator and curve shaper will have to be realigned. For this reason, the modification is only advisable if the frequency stability is still not good enough — even though it is high compared with many other synthesizers.

Figure 2a shows the original circuit, which has two source followers. Of these, only T2 affects the oscillator's frequency stability; the simplest conversion, therefore, will entail replacing this FET by a voltage follower using an LF 356H. The rest of the circuit can remain unchanged, as shown in figure 2b. However, the oscillator and the curve shaper must be re-adjusted, since this modification will alter both the amplitude and the DC level of the sawtooth.

Figure 3a gives the modified component layout for the circuit shown in figure 2b. Connections 1 and 5 of the metal-case version of the LF 356 (IC12) are not used and these wires can be cut short. Connection 6 is soldered to 2. R17 and T2 are unsoldered from the VCO board and IC12 is mounted, as shown in figure 3a.

If a new VCO module is to be built from scratch, more extensive changes may be considered. Figure 2c shows the new circuit: FETs T2 and T3, source resistors R17 and R20, gate resistor R16, and trimmer P10 have all been removed. The voltage follower opamp (IC12) replaces both source followers. Resistor R18 is changed to 470 Ω. A metal film resistor is not strictly necessary. If the 'ultimate' in temperature stability is required, though, a 470 Ω/2% metal film resistor should be used.

Figure 3c shows the modified component layout for new VCO's. IC12 substitutes T2/R17; a wire link to the left of it replaces T3/R16.

The FET opamp in the new oscillator circuit, as shown in figure 2c, not only improves the frequency stability, but also reduces the component count in comparison with the original circuit. Furthermore, the removal of preset P10 makes the adjustment that much easier.

2a

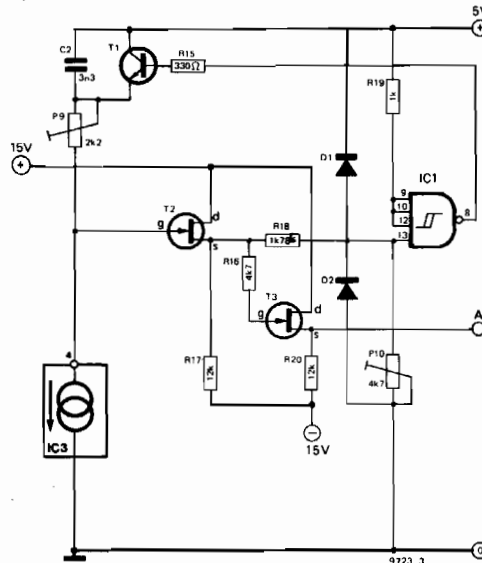

Figure 2a. The oscillator circuit in the VCO contains two FETs used as source followers; only T2 affects the frequency stability.

2b

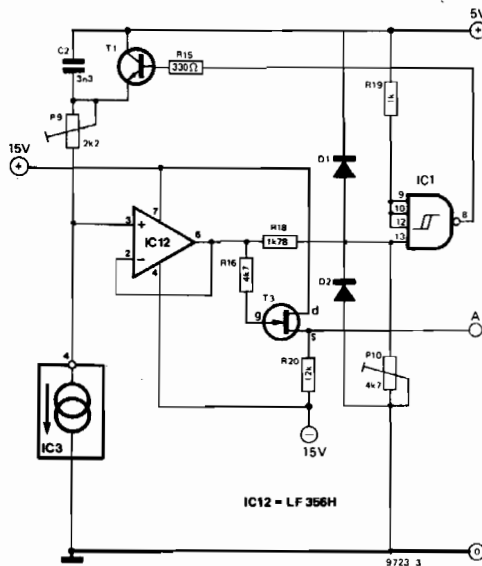

Figure 2b. The easiest modification, in order to improve the temperature stability of an existing VCO, is to replace T2 by an FET opamp (IC12).

2c

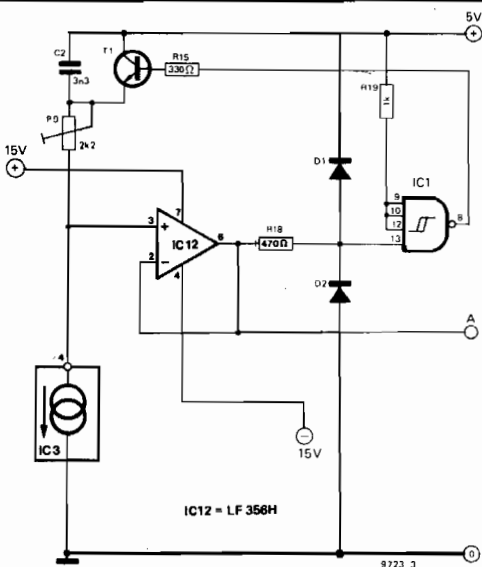

Figure 2c. When building a new VCO module, it is worth considering this simplified oscillator circuit. The FET opamp now replaces both source followers, and preset potentiometer P10 can be omitted.



3a

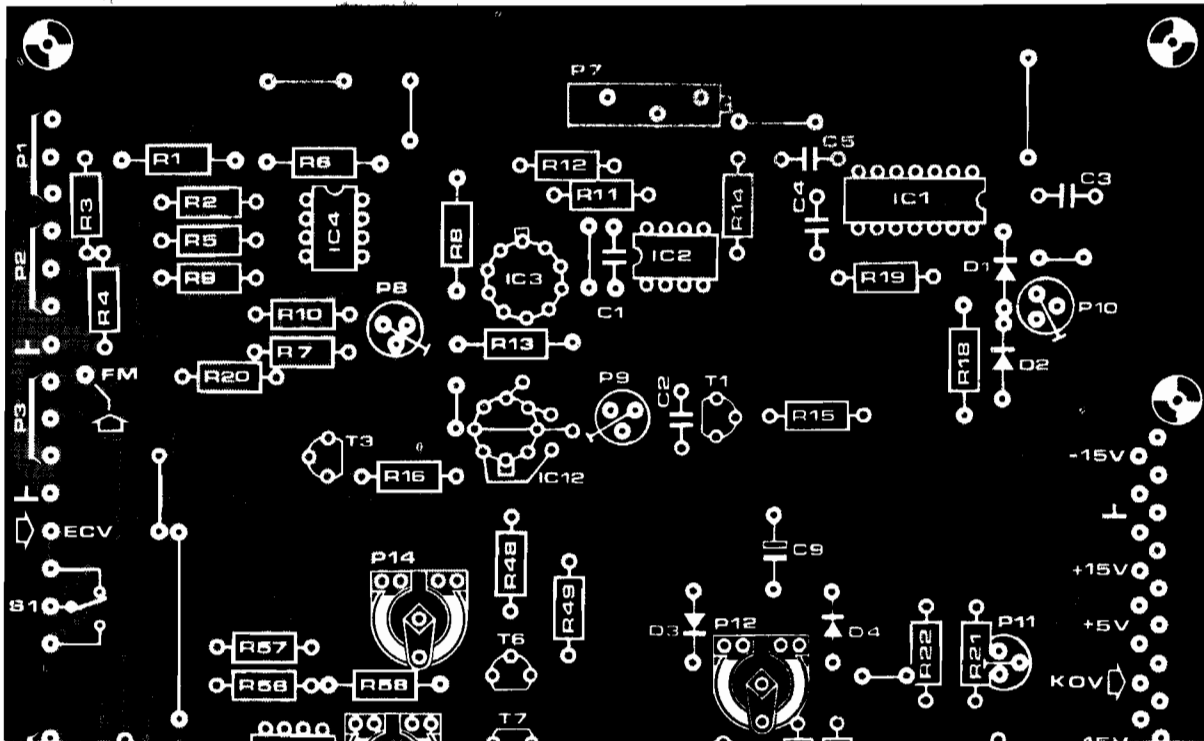

Figure 3a. This modified component layout corresponds to the circuit given in figure 2b.

3b

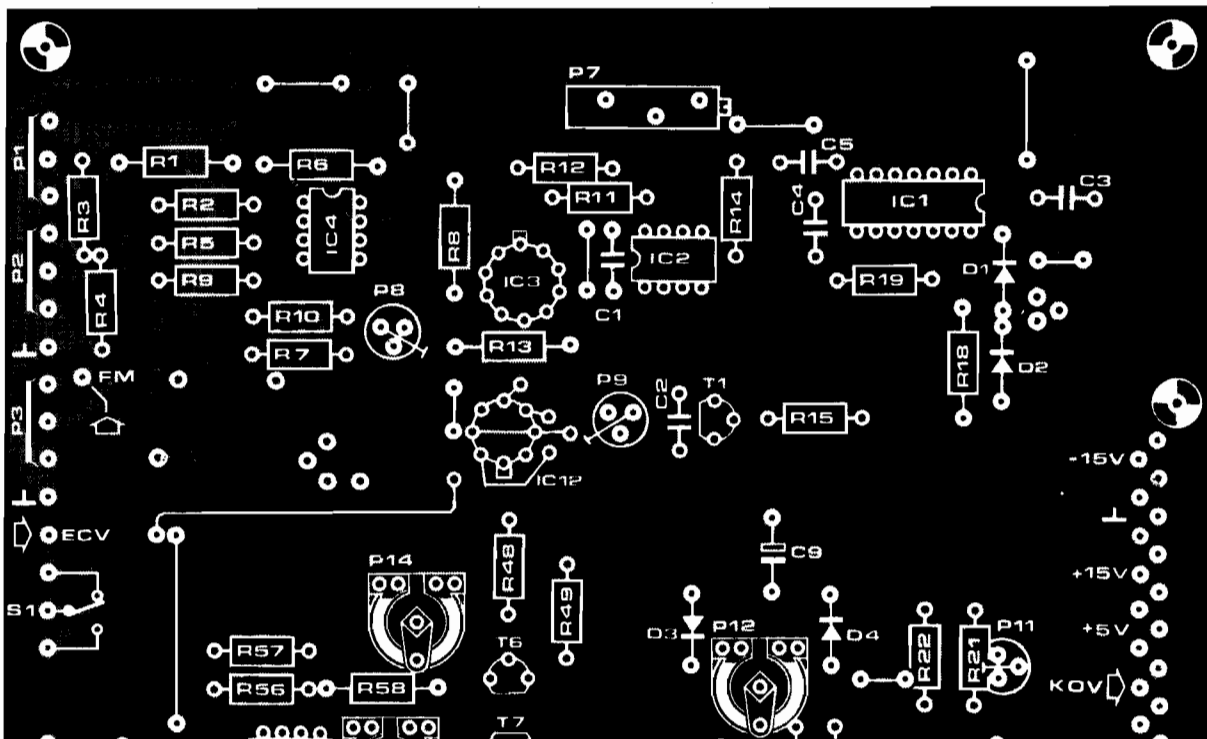

Figure 3b. Component layout for the simplified version of the oscillator circuit given in figure 2c.